

Basi statiche di bloccaggio, idrauliche, autocentranti - MIA1-G2
Clamping force blocks, hydraulic, centric clamping - MIA1-G2
Kraftspannblock, hydraulisch, zentrisch spannend - MIA1-G2
Étaux de serrage, hydraulique, autocentreurs - MIA1-G2



Dati tecnici

- Pressione d'esercizio: max 45 bar in idraulica (120 bar su richiesta)
- Precisione di ripetibilità: MIA1-G2- 20... 50 0.02 mm
MIA1-G2- 54... 80 0.03 mm
con 100 cicli
- Temperatura d'esercizio: da 5°C a 60° C
- Sistema di funzionamento: cinematica a piani inclinati con guida forzata e trasmissione della forza applicata alle superfici
- Apertura/chiusura parallela con corse totali dei carrellini da 6 a 72 mm
- Applicazione tramite: fori per spine H7
- Materiale corpo: acciaio trattato
- Materiale parti funzionali: acciaio trattato
- Azionamento: olio filtrato (10µm) viscosità 46 mm²/s a 40° ISO VG; max 60° C;
- Attacchi: laterali - base
- Manutenzione: lubrificare tramite ingrassatori ogni 5.000 cicli in lavorazione, ogni 100.000 cicli con presa di manipolazione
- Optional: controllo posizione dita mediante sensori di prossimità

Technische Daten

- Betriebsdruck: max 45 Bar hydraulisch (120 Bar auf Anfrage)
- Wiederholgenauigkeit: MIA1-G2- 20... 50 0.02 mm
MIA1-G2- 54... 80 0.03 mm
über 100 Zyklen
- Betriebstemperaturbereich: von 5°C bis 60° C
- Kinematik/Futterkolben: Keilhakenprinzip, für hohe kraftübertragung und zentrisches Spannen
- Parallel Öffnen/Schliessen, Gesamthub der Schlitten 6 bis 72 mm
- Ausrichten der Gehäuse durch Verstiftung H7
- Gehäuse und Funktionsteile aus gehärtetem Stahl
- Betätigung: hydraulisch über gefiltertes Öl (10µm) Viskosität 46 mm²/s bei 40° ISO VG; Max 60° C
- Druckluftanschlüsse: Über die Seitenflächen - Grundflächen
- Schmierintervalle: bei Einsatz auf Zerspanungsmaschine alle 5.000 Schaltspiele, bei Handhabungsprozessen alle 100.000 Schaltspiele
- Zubehör: Näherungsschalter

Technical data

- Operating pressure range: max 45 bar with oil (120 bar on request)
- Repeatability accuracy: MIA1-G2- 20... 50 0.02 mm
MIA1-G2- 54... 80 0.03 mm
with 100 cycles
- Operating temperature range: from 5°C to 60° C
- Operating principle: wedge and piston design with mechanically restricted guidance
- Stroke range from 6 to 72 mm
- Mounting: by means of bores for H7 pins
- Housing material: hardened steel
- Material for functional parts: hardened steel
- Actuation: filtered hydraulic oil (10µm) viscosity 46 mm² /s at 40° ISO VG; max 60°C
- Connections: sides - bases
- Maintenance: relubrifed via lubrication-nipples, every 5.000 cycles for tool clamping, every 100.000 in handling
- Options: proxy switch adjustment

Données techniques

- Pression de service: max 45 bar en hydraulique (120 bar sur demande)
- Précision de répétabilité: MIA1-G2- 20... 50 0.02 mm
MIA1-G2- 54... 80 0.03 mm
sur 100 cycles
- Température de service: de 5°C à 60° C
- Système de fonctionnement: piston et noix de commande à rampe
- Course parallèle des mors élevée de 6 à 72 mm
- Centrage par: trous pour goupilles H7
- Matière des pièces fonctionnelles: Acier trempé et rectifié
- Matière du corps: Acier trempé et rectifié
- Fonctionnement: huile filtré (10µm) viscosité 46 mm²/s à 40° ISO VG; Max 60° C
- Conduites: sur la côté - sur la base
- Maintenance: lubrification par graisseurs d'huile tous les 5.000 cycles avec serrage de pièces à usiner, les 100.000 cycles avec serrage de manipulation
- Accessoires: trous pour détecteurs

Basi statiche di bloccaggio, idrauliche, autocentranti - MIA1-G2
Clamping force blocks, hydraulic, centric clamping - MIA1-G2
Kraftspannblock, hydraulisch, zentrisch spannend - MIA1-G2
Étaux de serrage, hydraulique, autocentrents - MIA1-G2

Griffa di base SV
Base jaw SV
Grundbacke SV
Mors de base SV

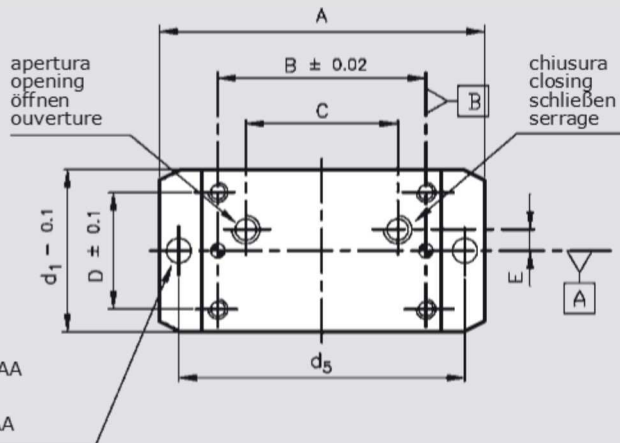

Boccola per proximity Ø AA
 Bush for proximity Ø AA
 Näherungsschalter Ø AA
 Trous pour détecteur Ø AA

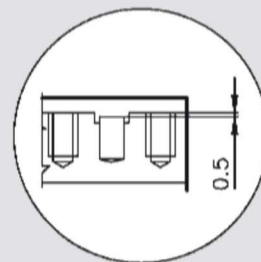
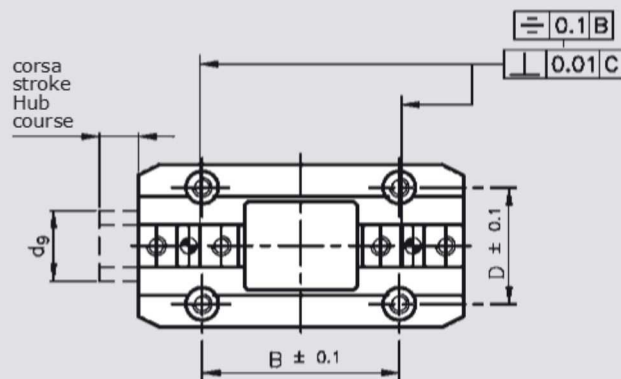
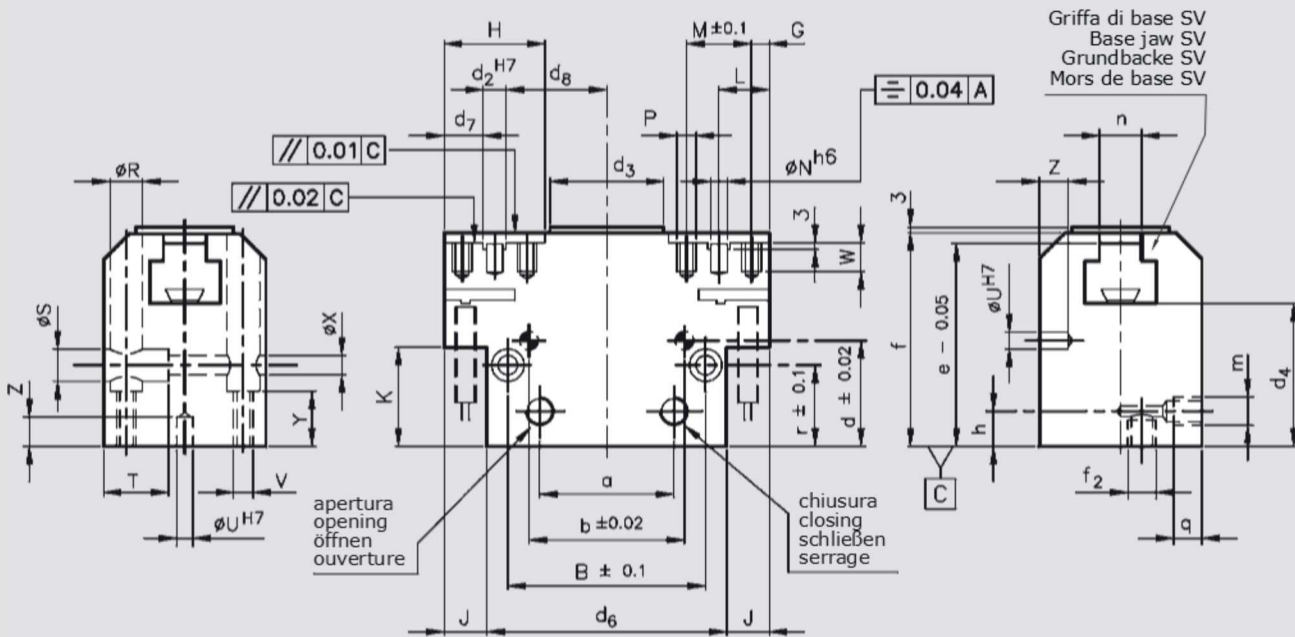

Basi statiche di bloccaggio, idrauliche, autocentranti - MIA1-G2
Clamping force blocks, hydraulic, centric clamping - MIA1-G2
Kraftspannblock, hydraulisch, zentrisch spannend - MIA1-G2
Étaux de serrage, hydraulique, autocentreurs - MIA1-G2

Type	A	B	C	D	E	G	H	L	M	N	P	R	S	T	U	V	Z	Y	X	W	J
MIA1 G2 20	68	42	28	27	8	4	21	10.5	13	4	M4	7.5	7.5	13	4	M5	4	16	4.5	7	8
MIA1 G2 25	80	52	36	32	9	5	25	13	16	5	M5	7.5	9	16	4	M5	6	15	5.5	9	8
MIA1 G2 32	100	66	44	38	13	6	32	16	20	6	M6	9.5	11	19	5	M6	6	15	6.5	10	10
MIA1 G2 40	125	82	56	45	14	8.5	40	20.5	24	6	M8	11	14	25	6	M8	8	15	9	12	12.5
MIA1 G2 50	160	100	70	56	12	9	50	25	32	8	M10	11	14	31	6	M8	10	19	9	15	17.5
MIA1 G2 54	180	120	76	60	14	9.5	55	27.5	36	10	M10	14	17	45	8	M10	10	20	11	16	20
MIA1 G2 60	200	130	80	68	18	11	62	31	40	12	M12	17	19	50	10	M12	12	22	13	20	22.5
MIA1 G2 80	250	164	112	90	28	17	80	41	48	12	M12	19	25	56	12	M16	16	30	17	22	25

Type	K	a	b	d	d ₁	d ₂	d ₃	d ₄	d ₅	d ₆	d ₇	d ₈	d ₉	e	f	f ₁	f ₂	h	m	n	Max fing. leng.
MIA1 G2 20	17	26	24	20	36	5	21	35.5	59	52	8	19	18	48	50	M3	M3	12	1/8	11	38
MIA1 G2 25	20	32	40	24	42	6	29	39	69	64	10	24	22	53	56	M3	M5	12	1/8	13	45
MIA1 G2 32	21	40	48	24	50	8	34	39	89	80	12	30	25	57	60	M3	1/8	15	1/8	15	60
MIA1 G2 40	24	52	62	27	60	8	43	44	112	100	16.5	38	30	64	68	M3	1/8	15	1/8	18	75
MIA1 G2 50	29	66	76	32	72	10	56	51	144	125	20	50	38	77	81	M3	1/8	18	1/8	22	80
MIA1 G2 54	32	72	94	38	80	12	66	62	162	140	21.5	56.5	40	94	98	M4	1/8	20	1/8	26	80
MIA1 G2 60	34	76	100	42	90	14	74	68	180	155	24	62	46	108	112	M5	1/8	22	1/8	30	90
MIA1 G2 80	50	104	124	56	120	16	88	88	224	200	33	76	55	128	136	M6	1/4	30	1/4	36	90

Tipo	r	q	AA	Corsa per griffa (mm) cod. 1 cod. 2		Forza di presa a 45 bar (N) code 1 code 2		Peso del pezzo raccomandato (kg) cod. 1 cod. 2		Tempo di serraggio (sec) apert. chius.		Olio consumato per doppia corsa (cm ³)	Massa morsa kg
Type	r	q	AA	Stroke for jaw cod. 1 cod. 2		Gripping force at 45 bar (N) code 1 code 2		Suggested work piece mass (kg) cod. 1 cod. 2		Approx time (sec) open. clos.		Oil consumption for double stroke (cm ³)	Mass vice kg
Typ	r	q	AA	Hub pro Finger (mm) Cod. 1 Cod. 2		Spannkraft bei 45 Bar (N) Code 1 Code 2		max. empfohlenes Werkstückgewicht (kg) cod. 1 cod. 2		Schließzeit (sec) öffn. schließ.		Ölverbrauch pro Doppelhub (cm ³)	Masse kg
Type	r	q	AA	Course par morse cod. 1 cod. 2		Force de serrage à 45 bar (N) code 1 code 2		Masse de la pièce à usiner recommand. (kg) cod. 1 cod. 2		Temps en environ (sec) ouver. serrag.		Consomm. huile pour double course (cm ³)	Masse mors kg
MIA1 G2 20	19	8.5	Ø4 M5	6	3	890	1480	3.8	6.8	0.25	0.3	8	0.8
MIA1 G2 25	20	8.5	Ø4 M8	8	4	1290	2150	5.8	10.4	0.25	0.3	16	1.2
MIA1 G2 32	20	8.5	Ø6.5 M8	10	5	3010	5080	12.2	22	0.3	0.35	26	1.8
MIA1 G2 40	22	8.5	Ø6.5 M8	13	6.5	4360	7120	21.3	38.4	0.35	0.4	57	2.9
MIA1 G2 50	27	8.5	Ø6.5 M8	16	8	8470	14280	33.6	60.6	0.4	0.45	101	5.4
MIA1 G2 54	28	8.5	M8 M12	20	10	10660	17830	42.6	76.7	0.5	0.55	146	8.5
MIA1 G2 60	32	8.5	M8 M12	25	12.5	12540	20960	51.4	92.5	0.65	0.75	237	11.5
MIA1 G2 80	48	12.5	M8 M12	30	15	25820	43140	82.5	143	1.1	1.35	411	24.5

- Peso trasportabile calcolato con $\mu = 0.1$ e $f_s = 2$. Con presa geometrica il valore potrà essere incrementato. La forza di presa è la somma aritmetica delle singole forze delle dita alla distanza di 15 mm dal piano griffa a 45 bar.
- Workpiece weight value at $\mu = 0.1$ e $f_s = 2$. In case of form fit clamping these values may be higher. Gripping force is an arithmetic sum of the individual forces occurring at fingers, distance 15mm at 45 bar.
- Empfehlung für max Werkstückgewicht gerechnet mit $\mu = 0.1$ e $f_s = 2$. Bei Formschluss sind größere Massen möglich. Die Greifkraft ist die arithmetische Summe der an den Greifbacken auftretenden Einzelkräfte in Abstand 15mm bei 45 Bar.
- Masse transportable calculée avec $\mu = 0.1$ e $f_s = 2$. Avec Prétension géométrique la masse pourrait être supérieure. La force de serrage est la somme arithmétique des forces individuelles des mors qui se forme à 15 mm à 45 bar.

Basi statiche di bloccaggio, idrauliche, autocentranti - MIA1-G2
Clamping force blocks, hydraulic, centric clamping - MIA1-G2
Kraftspannblock, hydraulisch, zentrisch spannend - MIA1-G2
Étaux de serrage, hydraulique, autocentreurs - MIA1-G2

Dati di carico ammissibili sulle dita
 Max. adm. forces and moments of fingers

Max. kräfte und Momente am Grundbacken
 Données de charge admissible

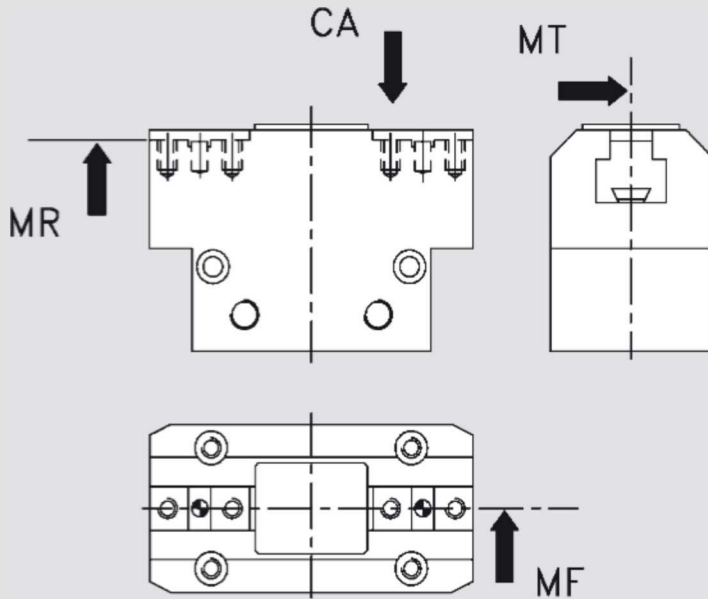

Type	CA (N)	MR (Nm)	MF (Nm)	MT (Nm)
MIA1 G2 20	500	35	30	20
MIA1 G2 25	1200	90	40	35
MIA1 G2 32	2200	100	55	55
MIA1 G2 40	6000	105	80	70
MIA1 G2 50	10000	110	90	90
MIA1 G2 54	12000	125	110	110
MIA1 G2 60	15000	160	150	150
MIA1 G2 80	20000	300	220	220

Versione a 120 bar - codice HP
 Version at 120 bar - code HP

Version bei 120 Bar - Code HP
 Version à 120 bar - code HP

Tipo	Corsa per griffa (mm)		Forza di presa a 120 bar (N)		Olio consumato per doppia corsa (cm ³)
	cod. 1	cod. 2	code 1	code 2	
Type	Stroke for jaw		Gripping force at 120 bar (N)		Oil consumption for double stroke (cm ³)
	cod. 1	cod. 2	code 1	code 2	
Typ	Hub pro Finger (mm)		Spannkraft bei 120 Bar (N)		Ölverbrauch pro Doppelhub (cm ³)
	Cod. 1	Cod. 2	Code 1	Code 2	
Type	Course par morse		Force de serrage à 120 bar (N)		Consomm. huile pour double course (cm ³)
	cod. 1	cod. 2	code 1	code 2	
MIA G2 40	13	6.5	4360	7120	19
MIA G2 50	16	8	8470	14280	37
MIA G2 54	20	10	10660	17830	59
MIA G2 60	25	12.5	12540	20960	94
MIA G2 80	30	15	25820	43140	200

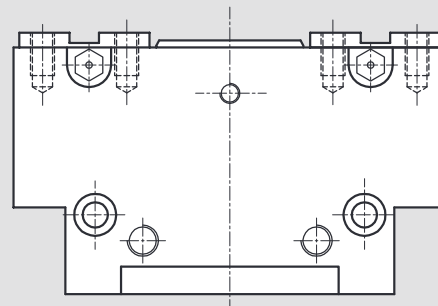

Basi statiche di bloccaggio, idrauliche, autocentranti - MIA1-G2
Clamping force blocks, hydraulic, centric clamping - MIA1-G2
Kraftspannblock, hydraulisch, zentrisch spannend - MIA1-G2
Étaux de serrage, hydraulique, autocentrents - MIA1-G2

Griffa di base HR
Base jaw HR
Grundbacke HR
Mors de base HR

Lubrificazione centralizzata
 Central lubrication
 Zentralschmierung
 Lubrication centralisé

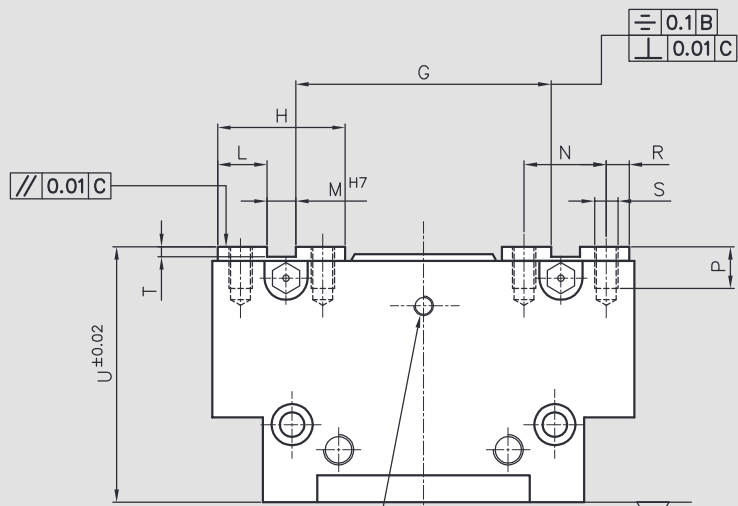
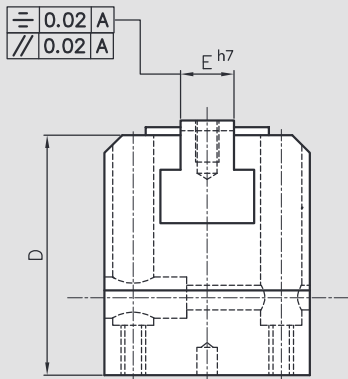
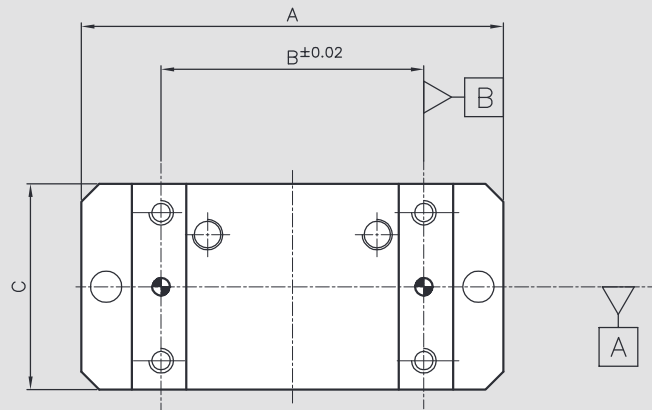
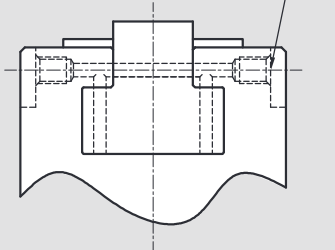

Pressurizzazione
 Pressurization
 Sperrluftanschluss
 Pressurisation

Type	A	B	C	D	E	G	H	L	M	N	P	R	S	T	U
MIA 1 G2 20	68	42	36	50	11	38	21	8	5	13	7.5	4	M4	3	54
MIA 1 G2 25	80	52	42	56	13	48	25	10	6	16	9	5	M5	3.5	61
MIA 1 G2 32	100	66	50	60	15	60	32	12	8	20	11	6	M6	4	65
MIA 1 G2 40	125	82	60	68	18	76	40	16.5	8	24	14	8.5	M8	4	73
MIA 1 G2 50	160	100	72	81	22	100	50	20	10	32	17	9	M10	5	87
MIA 1 G2 54	180	120	80	98	26	113	55	21.5	12	36	18	9.5	M10	5	104
MIA 1 G2 60	200	130	90	112	30	124	62	24	14	40	20	11	M12	5.5	119
MIA 1 G2 80	250	164	120	136	36	152	80	33	16	48	22	17	M12	6	143

Basi statiche di bloccaggio, idrauliche, autocentranti - MIA1-G2
Clamping force blocks, hydraulic, centric clamping - MIA1-G2
Kraftspannblock, hydraulisch, zentrisch spannend - MIA1-G2
Étaux de serrage, hydraulique, autocentrents - MIA1-G2

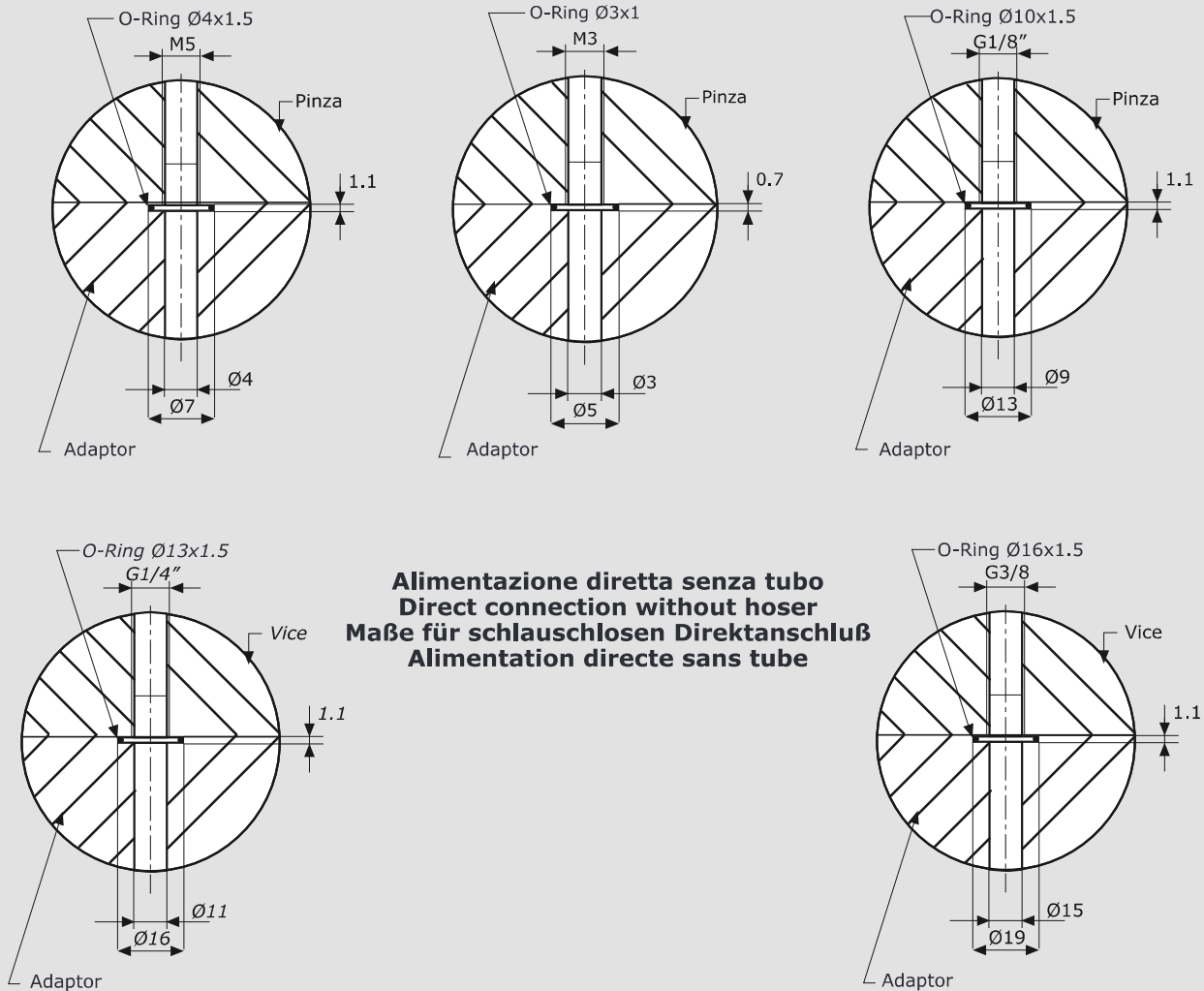

Esempio d'ordine - Ordering data

Bestellbeispiel - Exemple de commande

Tipo	Indicare bassa pressione LP alta pressione HP	Indicare versione griffa SV oppure HR	Codice 1 o 2	Per bocche e camme indicare B + valore
Type	Indicate low pressure LP high pressure HP	Indicate version base jaws SV or HR	Code 1 or 2	For bush indicate B + \varnothing proximity
Typ	zeigen, Niederdruck LP Hochdruck HP	zeigen Version Grundbacke SV oder HR	Hub 1 oder 2	Nährungsschalter Halterung Standard B + \varnothing Initiator
Type	Indiquer basse pression LP haute pression HP	Indiquer version mors SV ou HR	Code 1 ou 2	Pour douilles signaler B + \varnothing détecteur
MIA1-G2-50	LP	HR	C1	B8