

LINEAR ACTUATORS

Specification no. 477-X-XXX[†]

Satchwell Linear Actuators type 'AL' are reversing actuators having a linear output, for direct coupling to Satchwell lift and lay seat-type control valves or other seat valves requiring a linear driver over stroke lengths of up to 38mm (1½"), within the limits of output thrust stated overleaf and with compatible mounting arrangements.

These actuators are suitable for either two-position or modulating control, dependent on the controller or other switching device providing the input signal. The ALM is suitable for a mains power supply, the ALX is 24V, and the ALE is 24V, but accepts a 0-10Vdc input signal.

The ALE actuator can be set to operate a low hysteresis when used for tight control applications on microprocessor based controllers such as the KMC and MMC.



[†] For the full specification number replace the 4Xs with the appropriate figures from the 'TYPE' column in the table on page 2.

FEATURES

- Direct coupling to Satchwell seat valves without extra mounting brackets or linkage kits, saving site time
- Direct coupling to other makes of seat valves, where stroke, thrust and mounting are compatible
- Universal for valve strokes, up to 38mm (1½"). Actuator stroke is self-setting to suit valve stroke, including ALE by simple adjustment
- Alternative stroke times, to suit application
- Manual operation or override facility built-in
- Standard or low hysteresis selection on ALE to cater for different application types
- Case sealed to IP 54 as standard
- Auxiliary switch kit available, see 'Accessories'



MLI 3.401 - Mounting Instructions
Valves
DS 4.410 - VZ, VSF, VZF
DS 4.610 - MZ, MJF, MZF

SPECIFICATIONS

TYPES	ALM 1601	ALX 1201	ALX 1251	ALE 1302	ALE 1327	ALE 1352	ALE 1376
STROKE	Standard	Standard	Short	Standard	Standard	Short	Standard
POWER SUPPLY:	220 to 240V +10% to -15%, 50/60 Hz	24V ±10%, 50/60 Hz supplied by a transformer conforming to EN 60742		24V ±10%, 50/60 Hz supplied by a transformer conforming to EN 60742			
POWER CONSUMPTION: LIMIT & TRANSFER SWITCH RATING:	4.5 VA 5A	3.5 VA 0.75A	3.5 VA 0.75A	9.5 VA -	12 VA -	9.5 VA -	12 VA -
RUNNING SPEED: 1.8 s/mm (46 s/in) 2.5 s/mm (64 s/in) 5.0 s/mm (127 s/in) 8.5 s/mm (216 s/in)	- - - •	- - - •	- - • -	- - - •	- • - -	- - • -	• - - -
MAXIMUM STROKE: 16 mm (5/8") 38mm (1½")	- •	- •	• -	- •	- •	• -	- •
THRUST 311N 538N	- •	- •	• -	- •	- •	• -	- •
AUXILIARY SWITCHES	Two 5A, 250V Adjustable Use kit 831-1-211	Two 5A, 250V Adjustable Use kit 831-1-211	One 5A, 250V Fixed Built-in	Two 5A, 250V Adjustable Use kit 831-1-211		One 5A, 250V Fixed Built-in	Two 5A, 250V Adjustable Use kit 831-1-211
INPUT: CONTROL SIGNAL (for modulation)	Pulsed - Mains (220 to 240Vac) Voltage	Pulsed - 24V		0-10Vdc			
APPLICATION	Two-position control from thermostat, time switch or other switching device having (220/240Vac) mains rated changeover contacts. Modulating control from any controller having a 3-wire mains output (220 to 240Vac).	Modulating control from any controller having a pulsed 24V output.		Modulating control from any controller providing a 0-10Vdc positioning signal. Start and Span adjustments, also DA/RA switch included. Refer to 'Operation'.			
ASSOCIATED CONTROLLERS:	CMC, CSMC CSC	MMC, CXR, CXT, IAC, URC CSC	-	MMC, KMC, DRTE, DDTE, DSTE, DWTE, CZT, BAS, IAC			MMC, KMC, BAS, IAC
ASSOCIATED VALVES: 2 - Port: See DS 4.110	VSF up to 25mm VZ up to 2"	VSF up to 25mm VZ up to 2"	-	VSF up to 25mm VZ up to 2"		-	VSF 32 to 50mm VZF 65 to 150mm
3 - Port: See DS 4.610	MJF up to 50mm MZ up to 2" MZF up to 150mm	MJF up to 25mm MZ up to 2"	-	MJF up to 25mm MZ up to 2"		-	MJF 32 to 50mm MZF 65 to 150mm
		MJF 32 to 50mm MZ 65 to 150mm	-	MJF 32 to 50mm MZ 65 to 150mm		-	MJF 32 to 50mm MZ 65 to 150mm

Action:	Reversing - modulating
Stroke Time:	See table above
Protection Class:	IP 54
Mounting Attitude:	See 'Installation Instructions' on page 5
Ambient Temperature Limits:	Operating: -20 to 50°C Storage: -40 to 70°C
Max. Ambient Humidity:	Operation & Storage: 95% rh non-condensing
Manual Operator and Override:	Standard feature with all types

ACCESSORIES

Auxiliary Switches: Kit 831-1-211 available for internal mounting. Two voltage-free change-over switches rated 5A, 250V. Adjustable, one from position 0 to 5, the other from position 5 to 10 (see Table on page 2 for usage).

Spindle Adaptor: Kit 862-1-402, ¼" 32-UNEF female x ¾" 24-UNF male. One supplied with each actuator, except ALX 1251 and ALE 1352, for which it is not required.

LINKAGE KITS

SPECIFICATION	VALVE MANUFACTURER	VALVE
LNK 1501	Landis & Gyr	VVF52
LNK 1502	Honeywell	V5011A
LNK 1503	Fisher	Y Body ¾" to 1½", A Body 1½"
LNK 1504	Fisher	Y Body 2" to 3", A Body 2" to 4"
LNK 1505	Hymatic	1700 ¾" to 1½", 1450 1¼", 1400R 1½"
LNK 1506	Hymatic	1400R 2" to 3", 1700 2" to 3"
LNK 1521	Siebe	VB up to 2"

Note: Actuators ALX 1251 and ALE 1352 are short stroke actuators and cannot connect to any valves using the linkage kits detailed in the above table.

CONSTRUCTION

Case:	Mild steel baseplate with moulded polycarbonate housing and removable terminal cover (fire resistant to UL94V-0).
Mounting Bracket:	Die cast aluminium
Protection Class:	IP 54
Drive:	Operates on screw-jack principle, driven by a reversible synchronous motor via a gear train.
Motor:	Split phase, capacitor reversing type, continuously rated.
Gear Ratio:	Standard speed (8.5 s/mm) 89:1 Medium speed (5.0 s/mm) 51:1 Fast speed (2.5 s/mm) 51:1 Super Fast speed (1.8 s/mm) 27:1
Spindle Coupling:	Freely rotating coupling, screwed: ¾" 24-UNF, female (ALM 1601, ALX 1201, ALE 1302, 1327, 1376) ¼" 32-UNEF, female (ALX 1251, ALE 1352)
Manual Operator & Override:	Hand operator with gear train disengagement feature.
Position Indicator:	Spindle anti-rotation plate moves against stroke scale on mounting bracket. Marked 0 to 10, representing 0 to 100% stroke. Fix scale to suit valve stroke, see 'Commissioning'.
Limit & Transfer Switches:	ALM & ALX: Load dependent switches, self-adjusting to match valve stroke. Control signal transfers from terminal 1 to 1T and 2 to 2T at respective limits of valve stroke (not electrically separate). ALE: Limit switches operate as for other actuators, but are internally connected between electronics card and motor windings. The transfer function is not necessary as multi-stage sequencing is derived from the 0-10 Volt output signals from the MMC or other multi-stage controllers.
Electronic Positioner: (ALE only)	Built-in printed circuit board connected by plug and socket for easy servicing. Internally connected to 1000 Ohm position feedback potentiometer, driven via gears from output shaft. Separate 0-10Vdc output signal available to monitor position or as a service aid.
Terminals:	Accept 2 x 1.5mm ² or 1 x 2.5mm ² cable
Conduit Entries:	Three x 21mm dia. knockout (detachable plate). (Use only bottom two on ALE.)
Auxiliary Switches:	Available as add-on accessory, see 'specification'. Note: ALX 1251 and ALE 1352 have one voltage-free single pole change-over switch rated 5A, 250V, built-in. Operating point, non-adjustable, is just before limit switch at position '0'.

VALVE STROKE TIME

This table gives total stroke time related to type, size and stroke of valve with type of actuator used.

VALVE TYPE AND SIZE	VALVE STROKE	VALVE STROKE TIME (Secs)			
		Actuator speed 8.5 s/mm	Actuator speed 5.0 s/mm	Actuator speed 2.5 s/mm	Actuator speed 1.8 s/mm
VZ & MZ ½" & ¾" VSF & MJF 15mm	9.5mm (⅜")	81	48	24	17
VZ & MZ 1"-2" VSF & MJF 20, 25mm	15.9mm (⅝")	135	80	40	29
VSF & MJF 32-50mm VZF & MZF 65-100mm	25.4mm (1")	216	–	64	46
VZF & MZF 125, 150mm	38mm (1½")	323	–	95	69

OPERATION

WHEN ACTUATOR IS OPERATING BEWARE OF TRAPPING FINGERS ETC.

The stroke of the 'AL' Linear Actuator is self-setting, using load-dependent switches, and is determined by the stroke of the valve. The ALE requires only a simple adjustment. Consequently, all specifications of actuator are universal and can be fitted to any seat valve having a stroke length within its nominal range, see details under 'Specifications' on page 2 and 'Valve Stroke Time' on page 3.



The drive can be disconnected for manual operation. A button located on the top surface of the enclosure is connected to a spring loaded push rod assembly. When depressed this moves the 2nd gear out of mesh, this mechanism can be locked in place by moulded ledges in the housing. Adjacent to this is a manual operation key, which is clipped in place on the top surface of the enclosure. The key can be fitted into a slotted feature in the end of the main drive shaft, which protrudes through the top surface of the enclosure. With the drive shaft disconnected from the gearbox/motor the manual operation key can be used to provide manual operation of the actuator.

ALM and ALX Actuators

The load-dependent switches perform a combined limit and transfer function. The limit switches de-energise the actuator at the end of stroke, whilst the transfer switches are used basically for sequence operation in multi-stage applications. Where additional switching or interlocking functions are required, use the add-on auxiliary switch accessory or built-in auxiliary switch detailed under 'Specifications'.

When energised between terminals 1 and 3, the actuator moves its spindle towards the fully extended position, to open a Satchwell 2-port or 3-port valve to the heat exchanger.

Conversely, when energised between terminals 2 and 3, the actuator moves its spindle towards the fully retracted position, to close the valve.

The load-dependent limit switches transfer the control signal from terminal 1 to 1T and from terminal 2 to 2T at the respective limits of valve stroke.

ALE Actuators

The ALE incorporates an electronic positioner and provides modulating control from any controller having a 0-10Vdc output. Using the 'START' and 'SPAN' adjustments, the actuator can be set to make a complete stroke over any span from 4 to 10 volts, starting at any point within the signal range, providing the sum of 'START' Volts plus 'SPAN' Volts does not exceed 10. The load-dependent limit switches operate basically as described for the ALM and ALX, but are internally connected between the electronics card and the motor windings.

Where additional switching or interlocking functions are required, use the add-on auxiliary switch accessory or built-in auxiliary switch detailed under 'Specifications'.

A separate 0-10Vdc output is available (terminal 11) for indicating actuator position to a Building Management System or as a Service and Commissioning aid.

ALE actuators can be set to operate a low hysteresis when used for tight control applications on microprocessor based controllers. The hysteresis is set by using a jumper link on the actuator PCB (see the commissioning section for details). A low hysteresis setting gives 200 steps between 0 and 10Vdc input and the standard setting gives 25 steps.

The following adjustments are made on the electronic printed circuit board, accessible behind the removable front cover.

ADJUSTMENT	MARKED	FUNCTION	Factory set at:
Slide Switch	⊕/⊖	Selects Direct or Reverse Action ⊕ signifies increase of actuator position with increasing input dc Volt signal. ⊖ signifies the reverse of this.	⊕
Potentiometer	START (0-10V)	Sets the command signal voltage at which the actuator commences to move from zero position.	0V
Potentiometer	SPAN (4-10V)	Sets the change in command signal Voltage which will cause actuator to move through complete stroke to positioning 10.	10V
Potentiometer	STROKE	Matches operation of actuator to desired valve stroke.	16mm

ALE ACTUATOR POSITION FOR TYPICAL SETTINGS OF 'START', 'SPAN' AND 'ACTION'

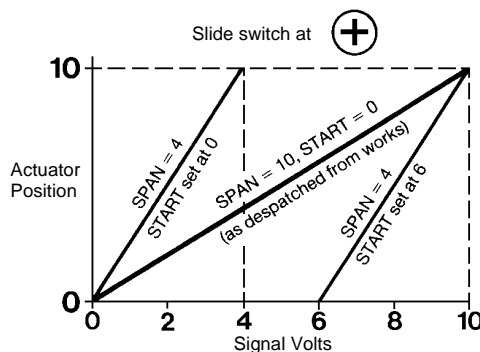
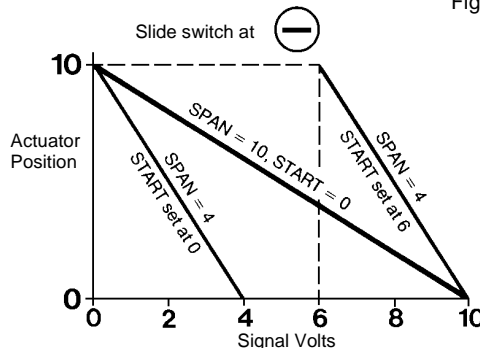

Fig.1



AUXILIARY SWITCHES

An auxiliary switch kit 831-1-211, comprising two single-pole changeover switches, is available as a separate accessory. The two electrically-separate switches can be independently set, one to operate at any point between positions 0 and 5 and the other between positions 5 and 10.

(Not applicable to ALX 1251 or ALE 1352, which have one fixed auxiliary switch built in).

INSTALLATION

Observe the following IMPORTANT points:

WARNINGS -

WHEN OPERATING A VALVE HANDLING FLUID ABOVE 100°C, DO NOT MOUNT ACTUATOR ABOVE VALVE, BUT TO ONE SIDE.

WHEN ACTUATOR IS OPERATING BEWARE OF TRAPPING FINGERS ETC.

- Do not switch on power supply until commissioning checks have been completed - see page 7.
- Steam Applications: Following a shutdown of the steam system it is important that the control valve is fully open before introducing steam into the pipeline (purging) or damage may occur to the actuator spindle or valve plug.
- Do not apply power unless the actuator is fitted to a valve.

- Ambient temperature must be within limits -20 to 50°C.
- Do not install valve with actuator directly underneath it.
- Allow sufficient clearance for fitting and wiring, also minimum of 110mm between manual operator knob and nearest obstruction.
- Complete mechanical fitting of actuator to valve BEFORE connecting electrical wiring. This avoids damage which may occur, due to load-dependent limit switches not being operated.
- Ensure location is reasonably clean and dry.

Note: The following diagrams are typical internal views (ALX 1251 and ALE 1352 are not shown).

ACTUATOR FITTING INSTRUCTIONS

1. a. Actuators ALM 1601, ALX 1201 and ALE 1302, 1327, 1376 are supplied with adaptor 'A' fitted, for direct coupling to valves with 1/4" diameter spindle. When coupling any of these actuators to valves with 3/8" diameter spindle, first loosen locknut 'F' then remove and discard adaptor 'A'.
 - b. Actuators ALX 1251 and ALE 1352 have coupling 'E' to suit valves with 1/4" diameter spindle only. Adaptor 'A' is not applicable.
2. Remove lug nut 'C' from valve bonnet, locate actuator mounting bracket over valve bonnet, replace lug nut and tighten, with actuator correctly positioned to give clear access for conduit entry and wiring.
3. For size 125 and 150mm valves, remove and discard lug nut and fix actuator mounting bracket to valve bonnet, using the four screws 'D' supplied.
4. Lift valve spindle into actuator coupling 'E' or adaptor 'A', as applicable and screw on fully. Do not over-tighten. Lock using nut 'B' supplied. Use manual operator to position coupling 'E' to required extension, as necessary, particularly when assembling to small size valves, but avoid over-extending or retracting actuator spindle to prevent malfunction or damage.
5. If subsequently removing the actuator to service valve gland, for example, it is **IMPORTANT** to isolate power supply to controller or actuator or otherwise select the 'Manual' position on the manual operator push button. This will avoid malfunction or damage due to actuator spindle being accidentally driven beyond its normal stroke limits.

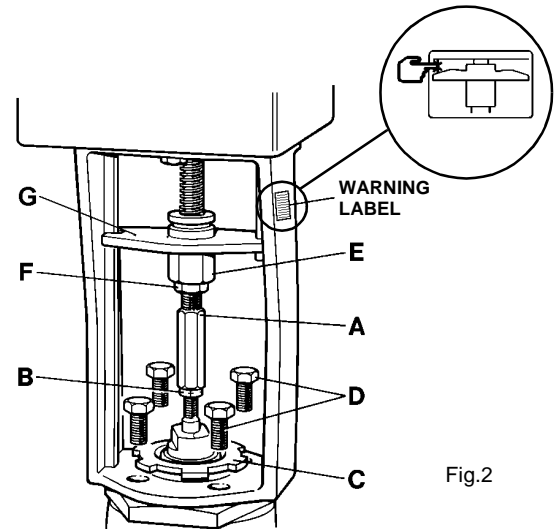

Fig.2

WIRING

1. Remove cover 'A' and conduit plate 'B' (see Fig.3). Fit flexible conduit to plate, allowing sufficient length to permit removal of the actuator.
2. Connect cables in accordance with system wiring diagram or refer to diagram inside cover in conjunction with controller diagram. Earth actuator, where applicable, using the top (ALM, ALX) or bottom (ALE) terminal screw. Observe 'Wiring precautions' (page 7). Keep wiring clear of internal moving parts.
3. Replace conduit plate and cover.

Caution

Do not switch on power supply until commissioning checks 1 to 6 have been completed.

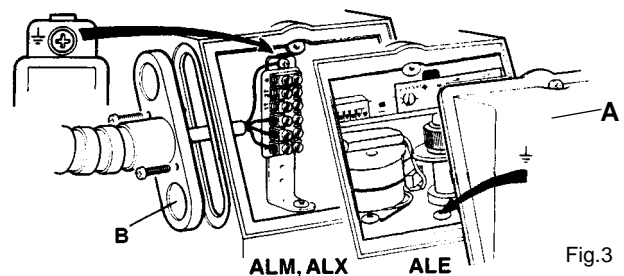

Fig.3

FITTING AUXILIARY SWITCHES - KIT 831-1-211

WARNING - AUXILIARY SWITCHES MAY BE AT MAINS POTENTIAL.

Note: When used with the ALE actuator, fit auxiliary switch kit AFTER carrying out stroke setting procedure. See 'Commissioning'.

1. Remove cover.
2. Undo fixing screw of main terminal block bracket 'A' and reposition adjacent to conduit entry (Fig.4). Use the locating hole to position bracket and tighten fixing screw. (Not applicable to ALE).
3. Push the switch operating rod 'C' into the large hole in the base of the actuator case (see Fig.5) until it clicks into the anti-rotation bracket (G above).
4. Fit auxiliary switch kit bracket 'B' in original position of main terminals, adjacent to vertical switch operating rod 'C' (Fig.5). Use the locating holes provided and tighten fixing screws.
5. Note that micro-switches are adjustable, one (S1, S2 & S3) between actuator positions 0 and 5, the other (S4, S5 & S6) between positions 5 and 10.
6. To adjust the switches, energise actuator (if commissioning in progress) at correct voltage and run to position at which one switch is required to operate. Alternatively, use manual operator facility.
7. Loosen micro-switch fixing screws 'D' and slide assembly with terminal block to point at which vertical operating rod 'C' just operates switch (Fig.6). Hold assembly in this position and re-tighten fixing screws.
8. Now energise actuator, or use manual operator, to run actuator in opposite direction to position at which second switch is required to operate, then repeat the setting procedure, as items 5 & 6.
9. Connect cables in accordance with system wiring diagram. Ensure that all wiring is kept clear of internal moving parts. Replace cover.

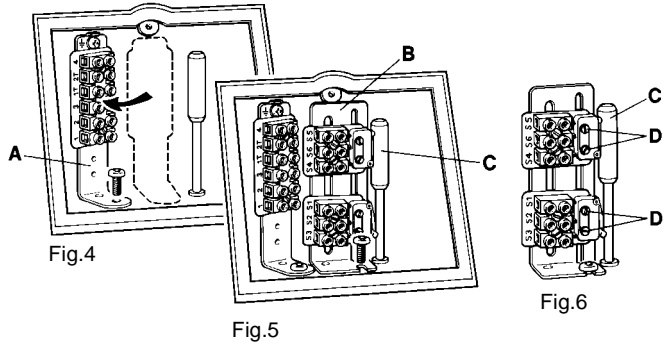

COMMISSIONING

WARNING - WHEN ACTUATOR IS OPERATING BEWARE OF TRAPPING FINGERS ETC.

BEFORE SWITCHING ON POWER SUPPLY:

ALM and ALX Actuators

1. Check that all control equipment is correctly located and fitted.
2. Check ambient temperature conditions.
3. Check that actuator has been correctly assembled to valve, up to the stage when electrical power is called for.
4. Remove terminal cover and check that all control circuit wiring is correct and in accordance with the overall control system wiring diagram. Check that the electrical supply voltage is correct.
5. Note: Wiring errors not only cause malfunctions; they may also damage controllers and/or actuators.
6. Replace terminal cover. Set manual override push button to 'Auto' position.
7. Now switch on power supply.
8. Check that the actuator functions correctly by operating the controlling switch or adjusting the controller set value above and below the temperature (or humidity) currently existing at the sensor (or simulated). This must be within the scale limits.

If the actuator forms part of a multi-stage system in which several actuators operate in sequence, wait until the appropriate stage is reached.

9. Whilst checking actuator travel over full stroke of valve, run actuator to fully retracted position. Select self-adhesive indication scale to match valve stroke, from set of four scales provided. Fix scale along outside edge of actuator mounting bracket, in position where it will be most clearly visible, lining up top edge of anti-rotation plate on actuator spindle with position '0' on scale (Fig.7).
10. If auxiliary switches are fitted, remove terminal cover to check for correct operation and switching functions. Replace terminal cover.

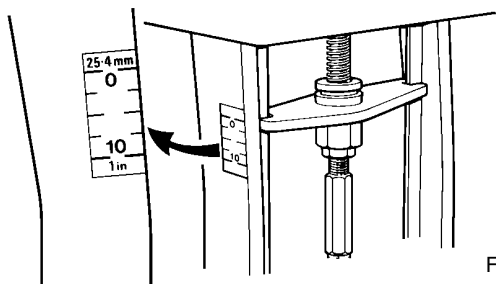

Fig.7

ALM, ALX WIRING PRECAUTIONS

WARNING - ALM ACTUATORS AND AUXILIARY SWITCHES (WHERE FITTED) ARE AT MAINS POTENTIAL. OBSERVE LOCAL WIRING REGULATIONS, EARTHING REQUIREMENTS AND ALL USUAL SAFETY PRECAUTIONS.

Wiring from actuator to controller*:	Max. length of 1.5mm ² cable unscreened	Max. resistance per conductor
24V/240V~ Supply	100m	5Ω

* When wiring to BAS outstations refer to the appropriate outstation data sheet for the wiring precautions.

For longer lengths, increase cable size and observe max. resistance. Screen feedback wiring, or use MICC or run in a separate conduit, when applicable.

Caution

Do not connect ALM or ALX actuators in parallel.

ALE Actuators

BEFORE SWITCHING ON POWER SUPPLY:

- Check that all control equipment is correctly located and fitted.
- Check ambient temperature conditions.
- Check that actuator has been correctly assembled to valve, up to the stage when electrical power is called for.
- Remove terminal cover and check that all control circuit wiring is correct and in accordance with the overall control system wiring diagram. Check that the electrical supply voltage is correct.

Note: Wiring errors not only cause malfunctions; they may also damage controllers and/or actuators.

Setting the Actuator

The following instructions MUST be followed to initially set the actuator stroke and each time the actuator is transferred to a different valve.

Set all adjustments as follows (see Fig.8):

Adjustment	Setting
START 'C'	10
SPAN 'D'	10
STROKE 'A'	max. (fully clockwise)
DA/RA SWITCH 'B'	+ (DA)
HYSTERESIS JUMPER 'G'	A-B or B-C

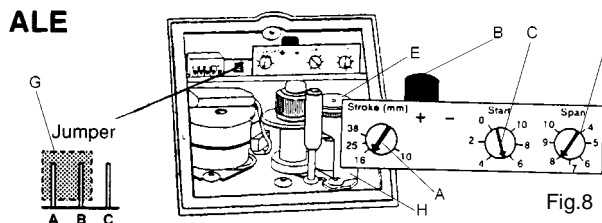
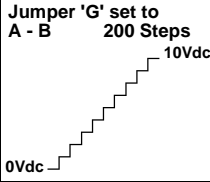
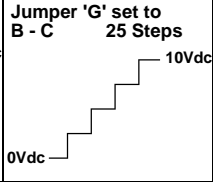

Fig.8

1. Set manual override push button to 'auto' position.
2. Remove wire from terminal 9, ensuring a 0Vdc supply.
3. Switch on 24V supply. The actuator drive screw will run until it is fully retracted (position 0) operating its limit switch.
4. Wait until the drive screw has stopped moving before continuing.
5. Loosen the pot fixing screw 'H'. By sliding the pot assembly towards you, disengage gear 'E' from the main drive shaft. Turn the pot gear 'E' by hand in the anti-clockwise direction (when viewed from above) until the end stop is reached. Gently slide the pot assembly back into position so that the pot gear 'E' engages with the main drive shaft. Do not apply too much force in meshing the gears as over pressure will result in reduced life. Re-tighten the location fixing screw 'H'.
6. Check that the voltage between terminal 7 and 11 is 0.1V ±100mV.
7. Reconnect wire to terminal 9.
8. Adjust controller set value to give 10Vdc output.
9. Check that the Voltage between terminals 7 and 9 is approximately 10Vdc.
10. Change the 'START' setting from '10' to '0'. The actuator drive screw will now run until it is fully extended (position 10).
11. Wait until the drive screw has stopped moving before continuing.
12. Adjust the 'STROKE' setting in an anti clockwise direction until Voltage measured between terminals 7 and 11 is 9.9V ±100mV.
13. Select and fix the appropriate self-adhesive stroke indication label to the actuator bracket. The relevant stroke length can be found on the appropriate Satchwell data sheet for the valve being used.
14. Re-set 'START', 'SPAN' and 'DA/RA' adjustments as required, to suit control system. DO NOT alter 'STROKE' setting. Re-check operation by adjusting controller set value so that actuator runs to position '0'. If limit switch does not operate, adjust 'START' setting very slightly anti-clockwise for 'DA' switch mode (clockwise for 'RA' switch mode) until limit switch does operate. Now adjust controller set value so that actuator runs to position '10'. If limit switch does not operate, adjust 'STROKE' setting very slightly clockwise for DA and anti-clockwise for RA until limit switch does operate. Re-adjust controller set value as required, to suit control system.

15. Set the required hysteresis for the actuator using jumper 'G'. Low hysteresis (200 steps) is used for tight control applications using microprocessor based controllers and standard hysteresis (25 steps) is used for analogue controllers and standard applications. See the table below for details:-

	 <p>Jumper 'G' set to A - B 200 Steps</p>	 <p>Jumper 'G' set to B - C 25 Steps</p>
MMC, KMC, IAC, BAS	Yes	Yes
DRTE, DDTE, DWTE, CZT	No	Yes

16. Fit, set and check auxiliary switches, if used, as described for ALM and ALX (section 9).

17. Replace terminal cover.

ALE WIRING PRECAUTIONS

WARNING -

IF AUXILIARY SWITCHES ARE FITTED AND USED AT MAINS POTENTIAL, OBSERVE LOCAL WIRING REGULATIONS, EARTHING REQUIREMENTS AND ALL USUAL SAFETY PRECAUTIONS.

Wiring from actuator to controller*:	Max. length of 1.5mm ² cable unshielded	Max. resistance per conductor
24V/240V~ supply	100m	5Ω
0-10Vdc signal	100m	50Ω

* When wiring to BAS outstations refer to the appropriate outstation data sheet for the wiring precautions.

For longer lengths of 24 Volt supply wiring, increase cable size and observe maximum resistance, also run separate return from terminal 7, as Fig.12.

Terminals 7 and 10 are both at ground potential, provided for convenience of wiring.

Where screening is required, use either screened cable, MICC or cables run in a separate conduit.

CONNECTION DIAGRAMS

BASIC DIAGRAM FOR ALM MAINS ACTUATORS

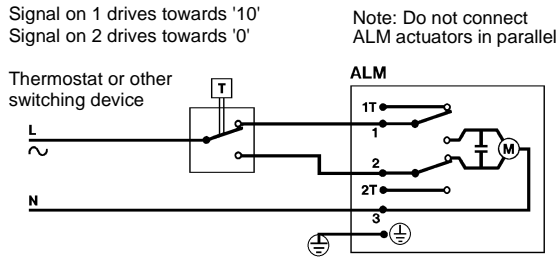

WARNING - MAINS VOLTAGE ISOLATORS MUST CONFORM TO EN 60335-1.

Fig.9

BASIC DIAGRAM FOR ALX 24 VOLT ACTUATORS

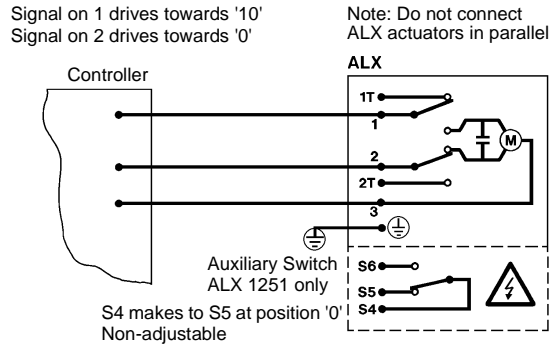

WARNINGS - AUXILIARY SWITCHES MAY BE AT MAINS POTENTIAL. MAINS VOLTAGE ISOLATORS MUST CONFORM TO EN 60335-1. 24VAC DEVICES MUST BE SUPPLIED BY A TRANSFORMER CONFORMING TO EN 60742.

Fig.10

BASIC DIAGRAM FOR ALE ACTUATORS

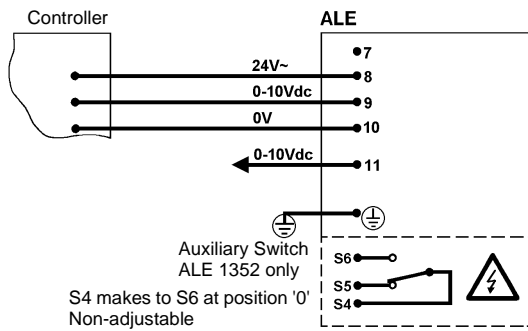

WARNINGS - AUXILIARY SWITCHES MAY BE AT MAINS POTENTIAL. MAINS VOLTAGE ISOLATORS MUST CONFORM TO EN 60335-1. 24VAC DEVICES MUST BE SUPPLIED BY A TRANSFORMER CONFORMING TO EN 60742.

Fig.11

SEPARATE 24 VOLT POWER SUPPLY TO ALE

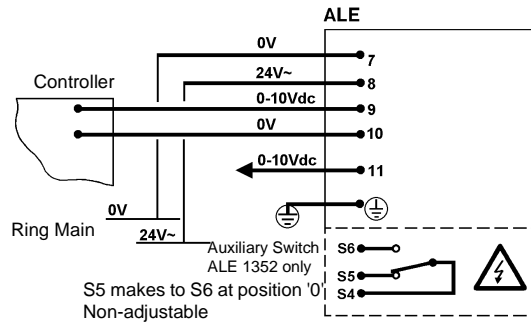

WARNINGS - AUXILIARY SWITCHES MAY BE AT MAINS POTENTIAL. MAINS VOLTAGE ISOLATORS MUST CONFORM TO EN 60335-1. 24VAC DEVICES MUST BE SUPPLIED BY A TRANSFORMER CONFORMING TO EN 60742.

Fig.12

TWO-STAGE SEQUENTIAL OPERATION from one 0-10 volt command signal incorporating dead zone

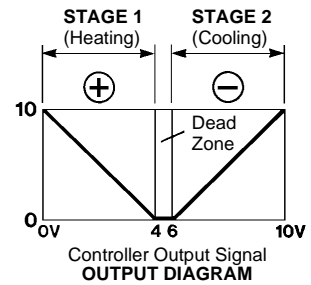
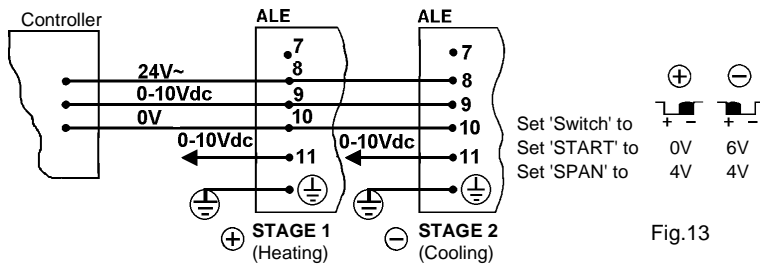
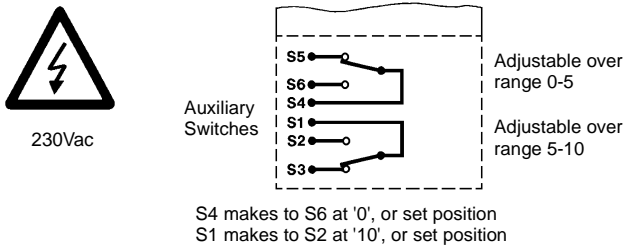

Fig.13

AUXILIARY SWITCH 831-1-211



WARNINGS - AUXILIARY SWITCHES MAY BE AT MAINS POTENTIAL. MAINS VOLTAGE ISOLATORS MUST CONFORM TO EN 60335-1. Fig.14

DIMENSION DRAWING

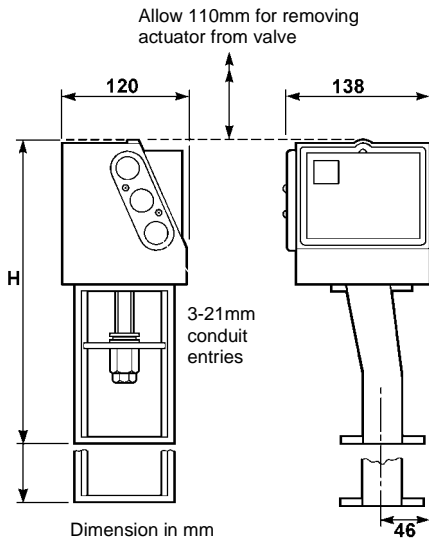

Refer to 'Maximum Stroke' details

Short Stroke Version Standard Stroke Version
 *H = 265mm (height) *H = 310mm (height)

Weight: 2.2Kg approx, Weight: 2.4Kg approx,

Satchwell

Satchwell Control Systems Limited

Farnham Road
 Slough
 Berkshire SL1 4UH
 United Kingdom

Telephone +44 (0)1753 550550
 Facsimile +44 (0)1753 824078
 www.satchwell.com

An Invensys company

WARNINGS -

CERTAIN MODELS (AND AUXILIARY SWITCHES WHERE FITTED) ARE AT MAINS POTENTIAL. LOCAL WIRING REGULATIONS AND USUAL SAFETY PRECAUTIONS MUST BE OBSERVED. NOTE EARTHING REQUIREMENTS.

MAINS VOLTAGE ISOLATORS MUST CONFORM TO EN 60335-1. WHEN ACTUATOR IS OPERATING BEWARE OF TRAPPING FINGERS ETC.

Cautions

- 24Vac devices must be supplied by a transformer conforming to EN 60742.
- Observe installation instructions on page 5.
- Observe wiring precautions on page 7.
- Do not apply power unless the actuator is fitted to a valve.
- Do not switch on power supply until commissioning checks have been completed - see page 7.
- Ensure wires are not inadvertently crossed over. Wiring errors not only cause malfunctions; they may also damage controllers and/or actuators.
- Steam Applications: Following a shutdown of the steam system it is important that the control valve is fully open before introducing steam into the pipeline (purging) or damage may occur to the actuator spindle or valve plug.
- Observe maximum and minimum ambient temperatures.
- Check thrust requirements and maximum differential of pressure of valve to be driven. Do not exceed rated output thrust.
- Interference with those parts under sealed covers renders the guarantee void.
- Design and performance of Satchwell equipment are subject to continual improvement and therefore liable to alteration without notice.
- Information is given for guidance only and Satchwell do not accept responsibility for the selection and installation of its products unless information has been given by the company in wiring relating to a specific application.