

# External Gear Pumps F, N, & G Series

RA 10 097/02.06  
Replaces 11.04

1/96

Fixed displacement pumps  
Sizes 4.0...63 cm<sup>3</sup> (.25...3.84 in<sup>3</sup>)

## Contents

Product Overview	4
Installation	7
Drive Arrangements	8
Multiple Gear Pumps	11
Pumps with Integral Valves	13
F-Series External Gear Pump	
- Ordering Code	14
- Product Index	15
- Drive Shafts	16
- Front Cover	17
- Port Connections	18
- Performance Ratings	19
- SAE O-Ring BOSS - Standard Porting	19
- SAE Porting-Specifications & Dimensions	19
- Performance Curves	20
- Drawings and Charts	23
N-Series External Gear Pump	
- Ordering Code	44
- Product Index	45
- Performance Ratings	46
- SAE O-Ring BOSS - Standard Porting	46
- SAE Porting-Specifications & Dimensions	46
- Performance Curves	47
- Drawings and Charts	49

## Page

## Contents

G-Series External Gear Pump	
- Ordering Code	68
- Product Index	69
- Performance Ratings	70
- SAE O-Ring BOSS - Standard Porting	70
- SAE Porting-Specifications & Dimensions	70
- Performance Curves	71
- Drawings and Charts	73
Multiple Pump Arrangements	
- Ordering Code	80
- Drawing Index	81
- Drawing and Charts	82
Seal Kits	92
Part Number Index	94

## Page

## Features

- Displacements of 4cc to 63cc
- Plain bearings for heavy duty applications
- Drive shafts SAE or ISO
- Multiple Pump Assemblies
- Port connections: flange or threaded
- Optimized pressure pulsation, which reduces noise levels and vibration excitation in the system
- Consistent high quality
- Considerably longer life due to reinforced shaft and housing



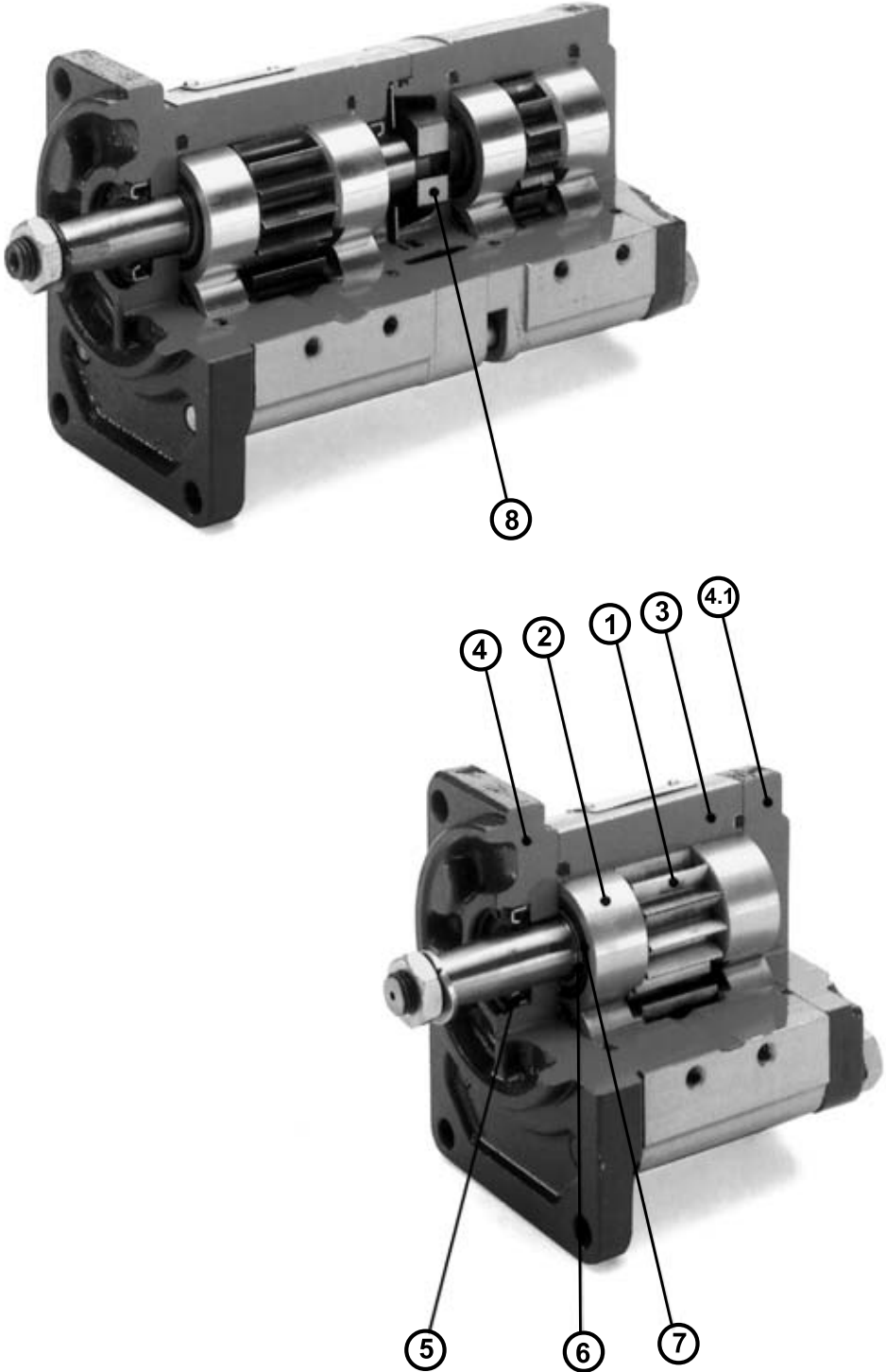

Fig. 1

- ① Gears
- ② Bearings
- ③ Extruded aluminium body
- ④ Covers
- ⑤ Shaft seal
- ⑥ Plain-bearing
- ⑦ Thrust pressure seal
- ⑧ Center coupling

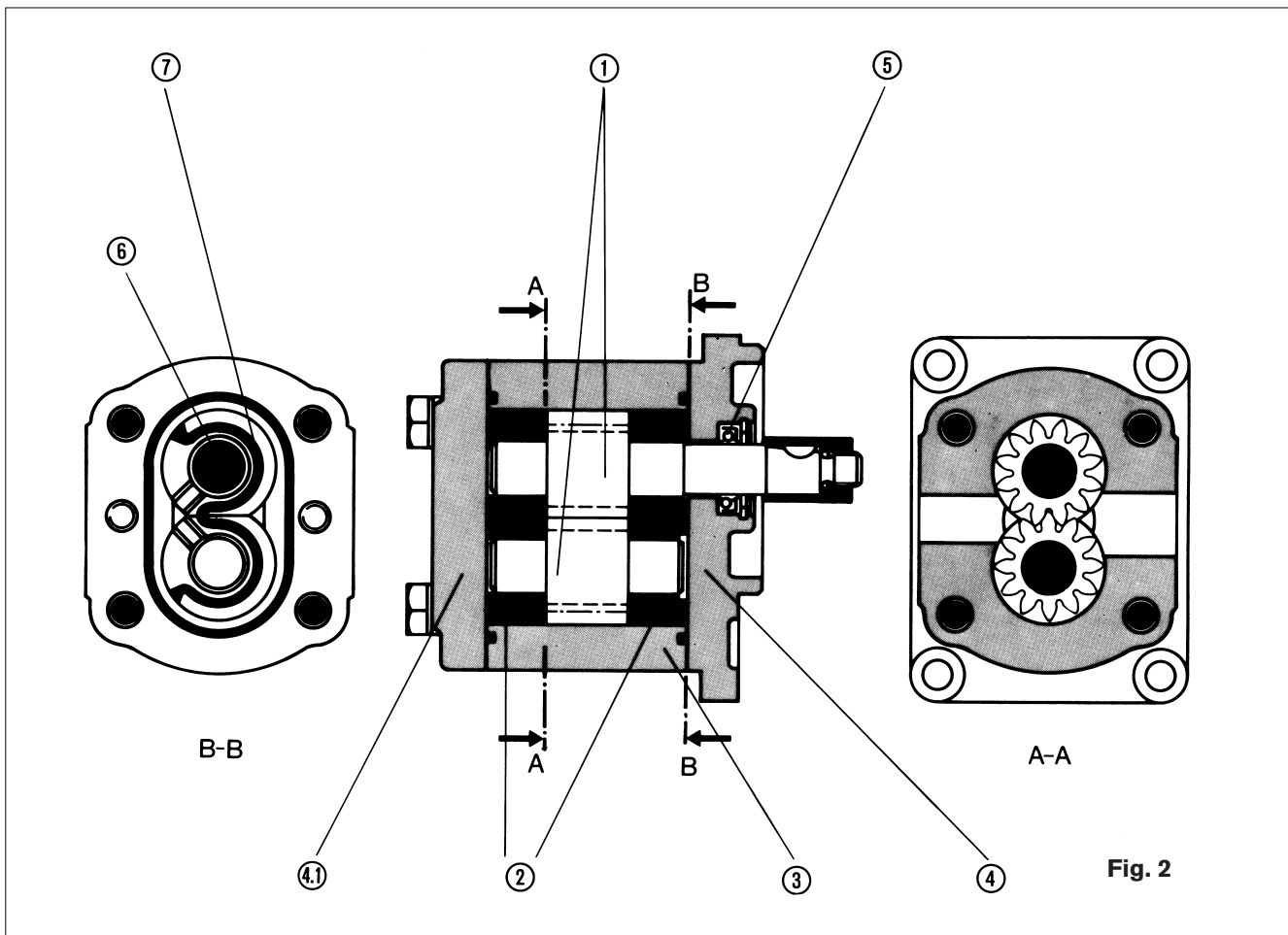

Fig. 2

There is no doubt that the gear-type pump is the most widely used design in hydraulic systems. It is simple in construction, reliable in operation and the most cost-effective way of generating hydraulic pressure.

Bosch Rexroth has been involved with the design, development and manufacture of gear pumps for many decades. Well-proven designs, the use of specially developed materials, constant testing and sophisticated mass production techniques ensure products of the very highest quality. Universal application is assured by a carefully graded range of sizes and a variety of different design options.

#### Basic design

The pump (see FIG. 2) consists essentially of a pair of gears (1) supported in bearings (2) and the body (3) with front and rear covers (4) and (4.1). The drive shaft protrudes from the front cover where it is sealed by the shaft seal (5).

The bearing forces are absorbed by special bearing-bushings with sufficient elasticity to produce surface contact instead of line contact (6). They also assure good operation under emergency conditions especially at low speed.

The gears have 12 teeth and this keeps both flow pulsation and noise emission to a minimum.

The internal sealing is pressure-sensitive, which provides optimum efficiency.

The bearings provide the seal at the ends of the gaps between the teeth, which carry the pressurized oil (2). The sealing zone between the gear teeth and the bearings is controlled by the admission of operating pressure to the rear of the bearings. Special seals (7) form the boundary of the zone. The radial clearance at the tips of the gear teeth is sealed by forcing them against the body.

## Specifications & Ratings

General	
Construction	external gear-type pump
Mounting	flange or through-bolting with pilot
Line connections	screw, flange
Direction of rotation (Fig. 4)	clockwise or counter-clockwise The pump may only be driven in the direction indicated.
Mounting position	any
Ambient temperature range	- 15 °C to +60 °C (+5°F to 140°F)
Fluid	mineral oil-based hydraulic fluids to DIN/ISO, other fluids to order
Viscosity – centistokes (mm <sup>2</sup> /s)	12 ... 800 mm <sup>2</sup> /s permitted range 20 ... 100 mm <sup>2</sup> /s recommended range ... 2000 mm <sup>2</sup> /s max. cold start
Fluid temperature range	- 15 °C to +80 °C (+5°F to 176°F)
Filter **) (further informations see page 27)	contamination class 10 to NAS 1638 obtained with filter $\beta_{25} = 75$

\*\*) During the application of control systems or devices with critical counter-reaction, such as steering and brake valves, the type of filtration selected must be adapted to the sensitivity of these devices/systems.

Safety requirements pertaining to the whole system are to be observed.

In the case of applications with high numbers of load cycles please check.

As viewed looking at end of drive shaft.

**Note:** Dimensional drawings always show clockwise-rotation pumps. On counter-clockwise-rotation pumps, the positions of the drive shaft and the suction and delivery ports are different.

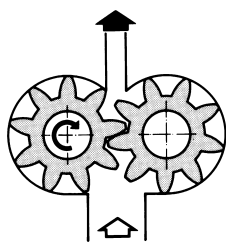

Clockwise rotation

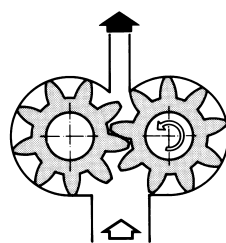

Counter-Clockwise rotation



### Definitions of pressures

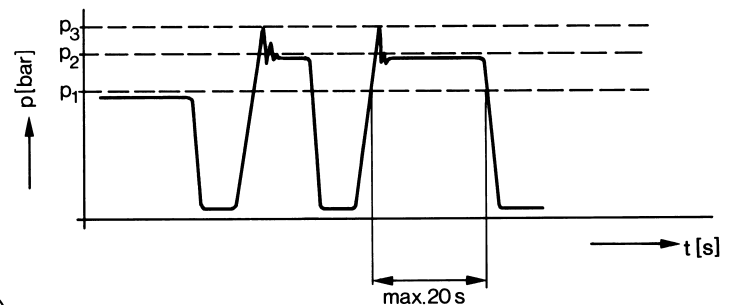

Duration of load

$p_1$  max. continuous pressure  
 $p_2$  max. intermittent pressure  
 $p_3$  max. peak pressure

Fig. 4

# Design calculations for pumps

The design calculations for pumps are based on the following parameters:

- V [cm<sup>3</sup>/rev] Displacement
- Q [l/min] Delivery
- p [bar] Pressure
- M [Nm] Drive torque
- n [rev/min] Drive speed
- P [kW] Drive power

It is also necessary to allow for different efficiencies such as:

- η<sub>v</sub> Volumetric efficiency
- η<sub>hm</sub> Hydraulic-mechanical efficiency
- η<sub>t</sub> Overall efficiency

The formulas down in Fig. 5 describe the various relationships. They include correction factors for adapting the parameters to the usual units encountered in practice.

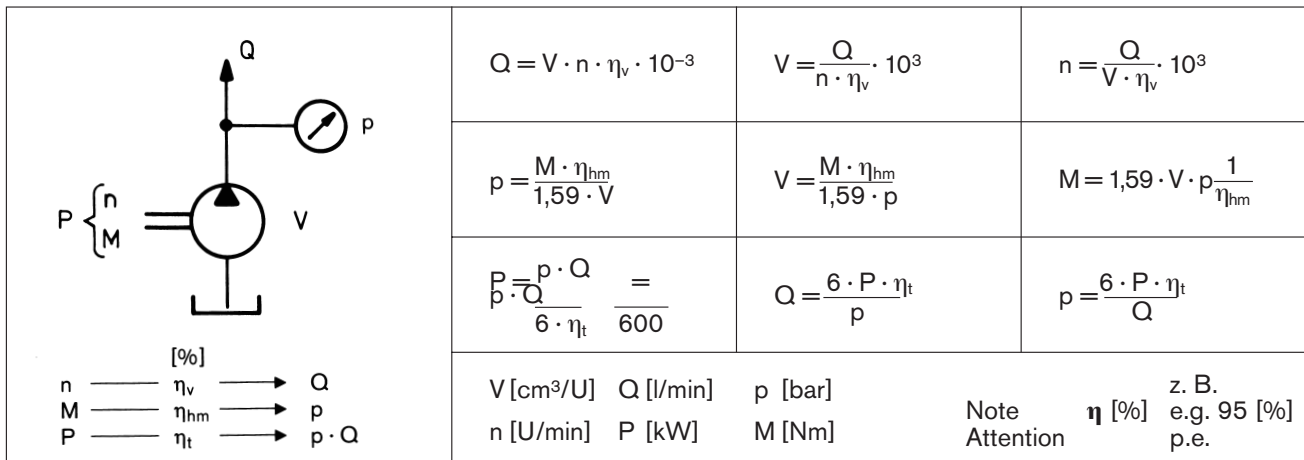

Fig. 5

## Notes on installation

Further information  
see "General operating and  
Maintenance Instructions".  
☎ 1 987 762 101

### Installation and commissioning

- Fill the pump with fluid before installing.
- Check the direction of rotation.
- Before installing the pump, clean the pipes thoroughly of all dirt, scale, sand, swarf, etc. Welded pipes in particular must be pickled or flushed out.
- Before starting up the pump for the first time, the entire hydraulic system must be thoroughly purged of air.
- Cover the shaft seal when spraying or brush-painting the equipment.
- Pay close attention to the specification, especially speeds, pressures and suction vacuum.

### Filter recommendations

By far the largest number of premature failures to gear pumps are due to contaminated fluid.

Since our guarantee does not apply to wear resulting from dirt in the system, we recommend filtering, which reduces the size and concentration of the contamination particles to a permitted minimum.

Operating pressure [bar]	>160	<160
Contamination class NAS 1638	9	10
Contamination class ISO 4406	18/15	19/16
Achieved with filter $\beta_x = 75$	20	25

**Fig. 6**

Full-flow filtering is always recommended.

The initial contamination of the fluid with which the system is filled must not exceed Class 10 to NAS 1638. Past experience has shown that even brand new fluids often exceed this value. In such cases a filter incorporating a special element will have to be used.

## Drive arrangements

### 1. Flexible couplings

The coupling must not transfer any radial or axial forces to the pump.

The maximum radial runout of shaft pilot is 0.2 mm. Refer to the fitting instructions provided by the coupling manufacturer for details of the maximum permitted shaft misalignment.

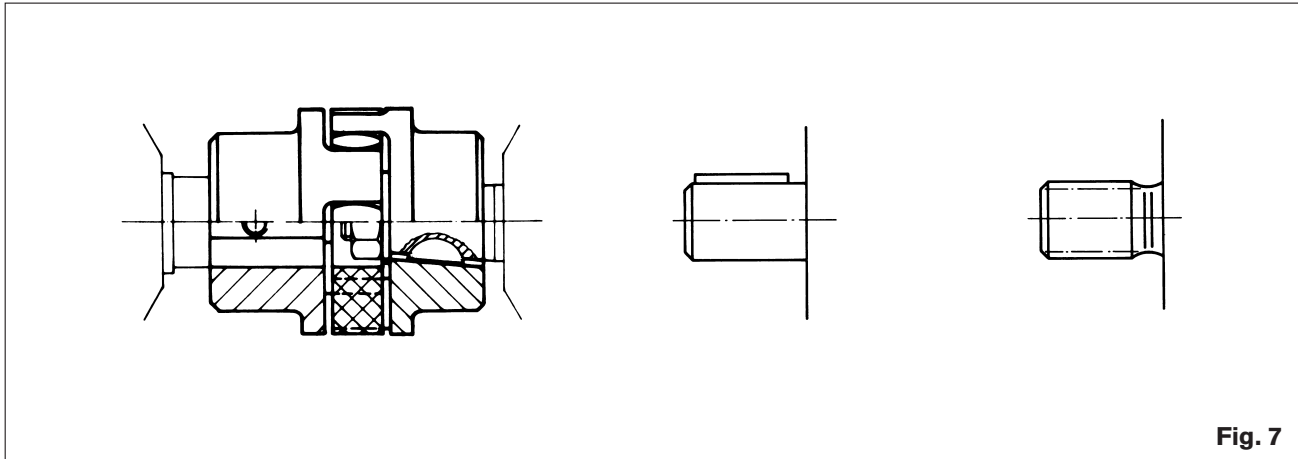
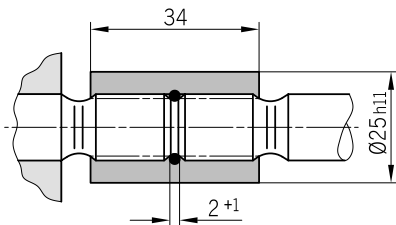

Fig. 7

### 2. Sleeve couplings

Used on shafts with DIN or SAE splining. **Note:** There must be no radial or axial forces exerted on the pump or sleeve coupling. The sleeve must be free to move axially. The distance between the pump shaft and drive shaft must be  $2^{+1}$ . Oil-bath or oil-mist lubrication is necessary.



Size  
B 17 x 14 DIN 5482  
 $M_{\max} = 190 \text{ Nm}$



**3. Tang Drive** (Ref. Fig. 8 & 9)

For the close-coupling of pumps to engines, gearboxes, etc. the pump shaft has a special drive dog which combines with a center coupling ③ (included with the pumps). There is no shaft seal.

The recommended arrangements and dimensions for the drive end and sealing are as follows.

① **Drive shaft**

Case-hardening steel DIN 17 210  
 e.g. 20 Mn CrS 5  
 case-hardened 0.6 deep; HRc 60 ±3.  
 Surface for sealing ring  
 ground without rifling  $R_t \leq 4\mu\text{m}$

② **Radial shaft seal**

Rubber-covered seal (see DIN 3760, Type AS or double-lipped ring).  
 Cut 15° chamfer or fit shaft seal with protective sleeve.

**F Series**

$M_{\text{max}}$ [Nm]	$V$ [cm <sup>3</sup> /rev]	$p_{\text{max}}$ [bar]
65	16	230
	19	190
	22,5	160

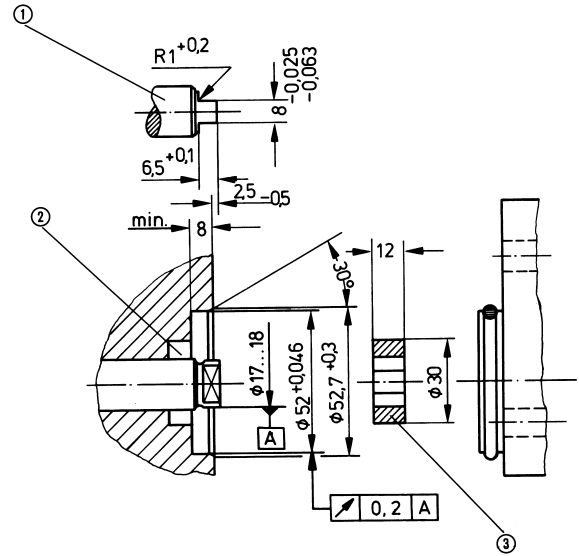
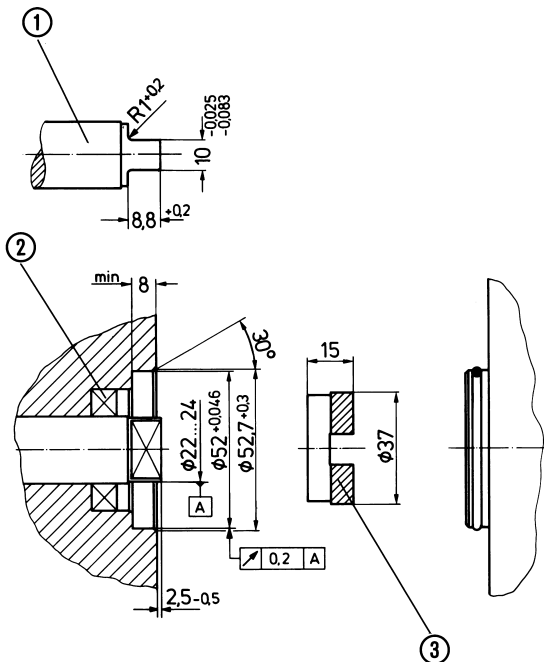

Fig. 8

**N Series**



**G Series**

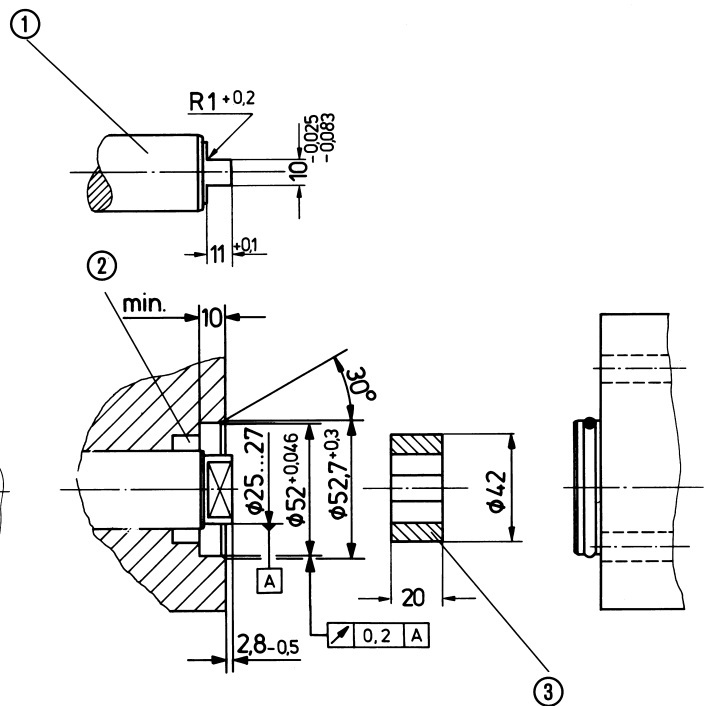
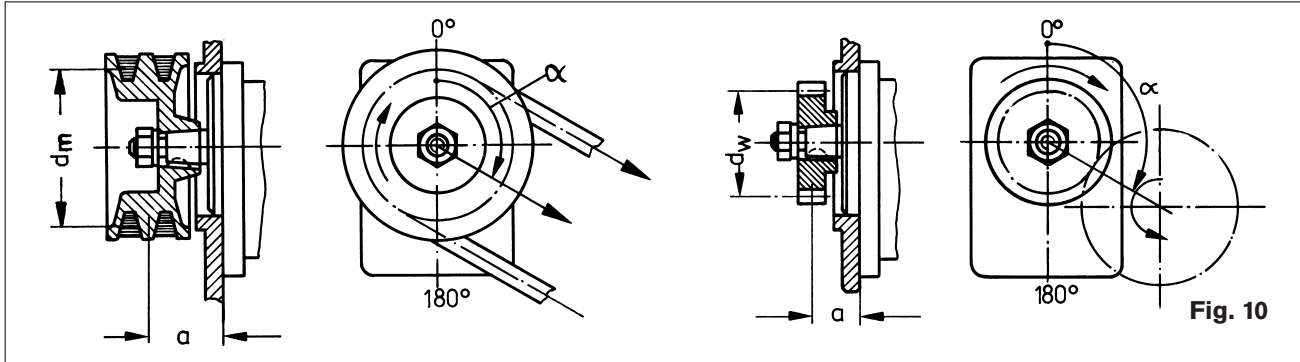

Fig. 9

**4. V-belts and gearwheels without outrigger bearings**

(Ref. Fig. 10)

When proposing to use V-belt or gearwheel drive, please submit details of the application for our comments (especially dimensions  $a$ ,  $d_m$ ,  $d_w$  and angle  $\alpha$ ).



**5. Outrigger bearings** (Ref. Fig. 11)

Outrigger bearings eliminate possible problems when the pumps are driven by V-belts or gearwheels. The diagrams below show the maximum overhung and thrust loads that can be tolerated referred to a bearing life of  $L_H = 1000$  hours.

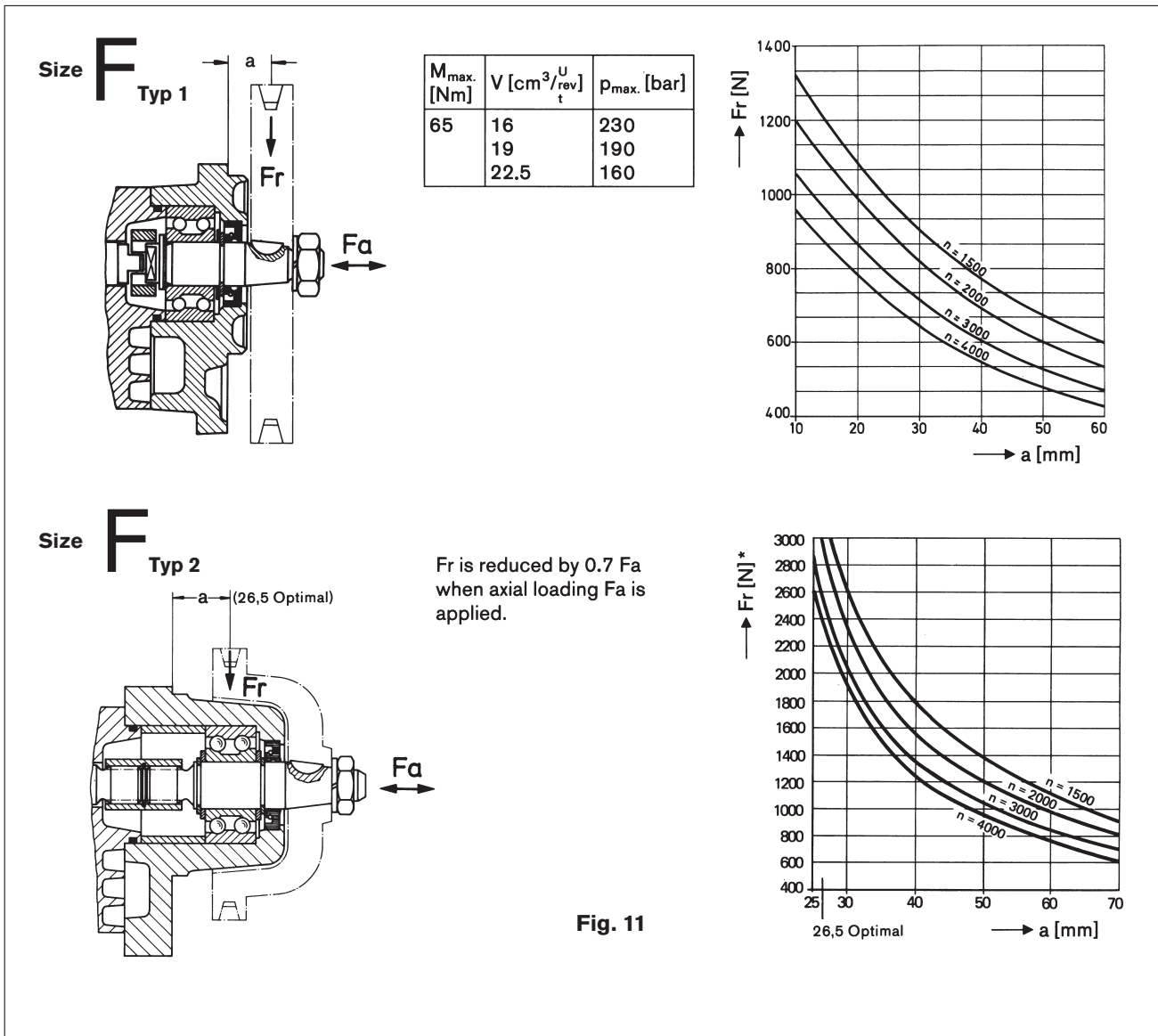

Fig. 11

## Multiple gear pumps

### F & N Series

Ref. Fig. 12

Gear pumps are well-suited to tandem combinations of pumps in which the drive shaft of the first pump is extended to drive a second pump, and sometimes a third pump in the same manner.

A coupling is fitted between each pair of pumps. In most cases, each pump is isolated from its neighbour, (i. e. the suction and delivery ports are separate).

**Specifications:** Basically, the specifications for the individual pumps apply, but with certain restrictions:

**Max. speed:** This is determined by the highest rated pump speed in use.

**Pressures:** These are restricted by the strength of the drive shaft, the transmissions and the couplings. Appropriate data is given in the dimensional drawings and the graph on the following page.

#### Multiple Gear Pumps

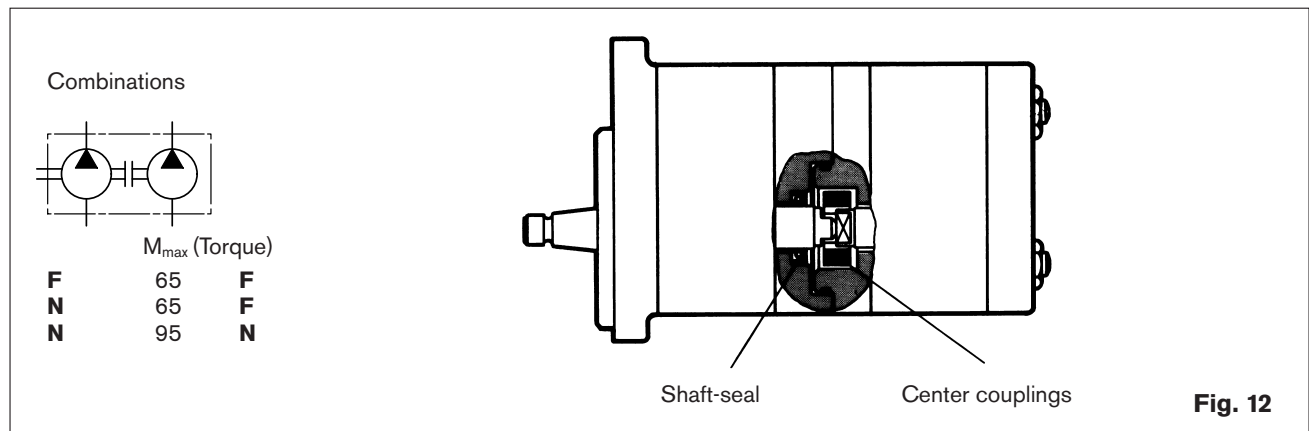

**Multiple pump units - Pressure & Torque Ratings**

In the case of Size F the center coupling for the second pump can carry a load of up to  $M_{max} = 65 \text{ Nm}$ . The pressure restriction for the second pump is as follows:

V [cm <sup>3</sup> /rev]	P <sub>max</sub> [bar]
16	230
19	190
22.5	160

If the first pump is driven through a dog and center coupling or Type 1 outrigger bearing, the pressure restrictions for both pumps are as indicated in the diagram below.

In the case of applications with high numbers of load cycles, please contact the factory.

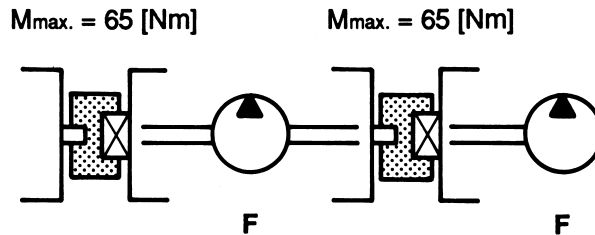

Reinforced transmissions are available for applications with higher transfer torques and/or torsional vibrations. Customized designs are available on request.

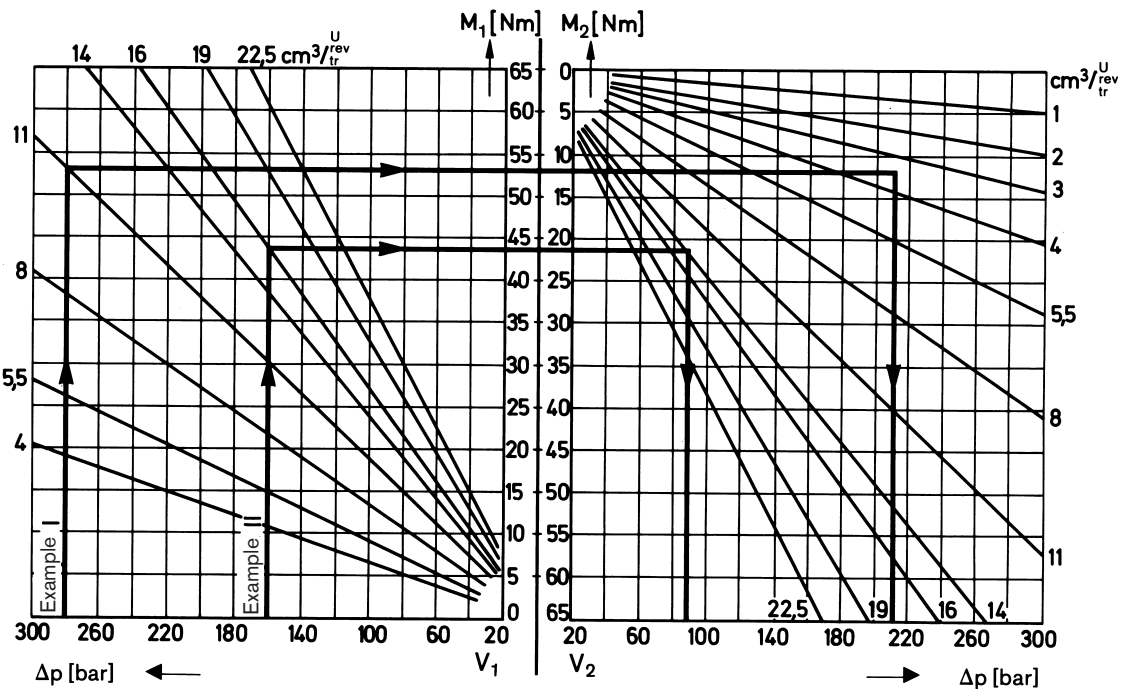

Beispiel, Example, Exemple

Fig. 13







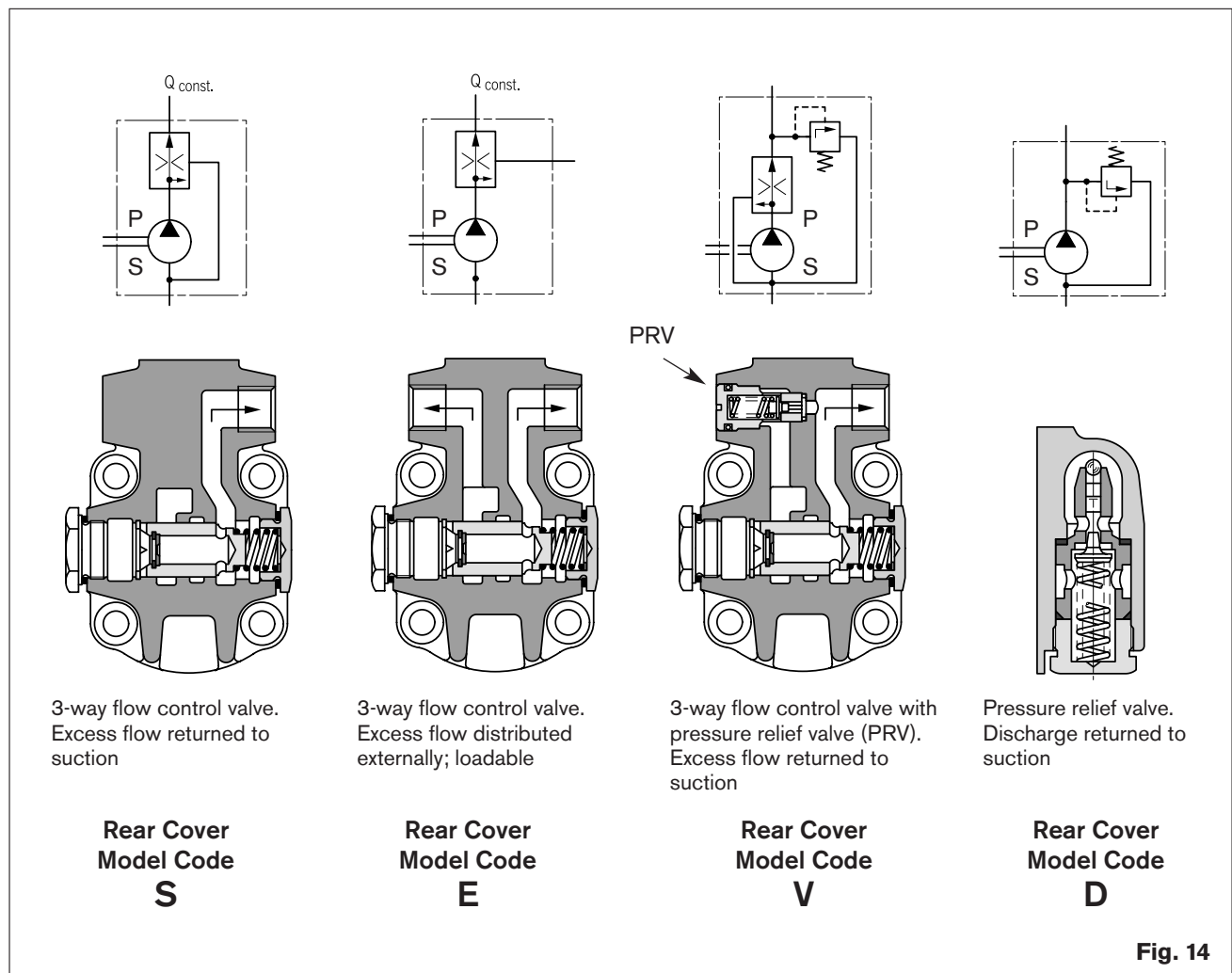















### Gear pumps with integral valves



In order to reduce external pipework it is possible to incorporate a flow control valve or pressure relief valve in the end cover of the pump. A typical application of this is in power-assisted steering systems. The pump delivers a constant flow irrespective of the speed at which it is driven. The excess flow is either returned internally to the suction or distributed externally to other items of equipment.



# Ordering Code (F Series Pump)

<b>AZ</b>	<b>P</b>	<b>F - 1</b> <input type="checkbox"/> <b>or 2</b> <input type="checkbox"/> <b>- 016</b>	<b>R</b>	<b>R</b>	<b>R</b>	<b>12</b>	<b>M</b>	<b>B</b>	<b>-</b> <input type="checkbox"/> <input type="checkbox"/> <input type="checkbox"/> <input type="checkbox"/> <b>-</b> <input type="checkbox"/> <input type="checkbox"/> <input type="checkbox"/> <input type="checkbox"/> <b>S</b> <input type="checkbox"/> <input type="checkbox"/> <input type="checkbox"/> <input type="checkbox"/>		
								PRV(bar)    FCV(l/min)	<b>Special Design*</b>		
<b>Function</b>								EXAMPLE: 180 bar, 9 l/min = 180 09 Use XXX if valve not applicable			
P = Pump											
<b>Size (F)</b>											
.26in <sup>3</sup> ( 4.1 cm <sup>3</sup> ) = 004											
.35in <sup>3</sup> ( 5.6 cm <sup>3</sup> ) = 005											
.51in <sup>3</sup> ( 8.2 cm <sup>3</sup> ) = 008											
.71in <sup>3</sup> (11.3 cm <sup>3</sup> ) = 011											
.89in <sup>3</sup> (14.3 cm <sup>3</sup> ) = 014											
1.03in <sup>3</sup> (16.5 cm <sup>3</sup> ) = 016											
1.22in <sup>3</sup> (19.5 cm <sup>3</sup> ) = 019											
1.43in <sup>3</sup> (22.9 cm <sup>3</sup> ) = 022											
1.59in <sup>3</sup> (25.4 cm <sup>3</sup> ) = 025											
1.78in <sup>3</sup> (28.5 cm <sup>3</sup> ) = 028											
<b>Direction of rotation</b>											
Right = R											
Left = L											
								<b>End cover</b> B - Standard A - Rear ports E - FCV, excess flow ext. V - PRV + FCV P - Priority flow control D - Pressure relief valve			
								<b>Seals</b> NBR = M FPM = P NBR, shaft seal in FPM = K			
<b>Drive shafts</b>				<b>Front flange</b>				<b>Line connections</b>			
Matching front flange											
<b>C</b>	Conical 1:5 (Tapered key)		<b>B</b>	<b>P</b>	<b>B</b>	Square flange Pilot Ø 80 mm		<b>20</b>	Rectangular flange		
<b>S</b>	Conical 1:5 for flange A (Tapered key)		<b>A</b>		<b>R</b>	SAE A 2-bolt		<b>12</b>	Thread (UN-2B) SAE O-ring BOSS		
<b>H</b>	Conical 1:8 (Tapered key)		<b>O</b>		<b>P</b>	Transmission flange Pilot Ø 50 mm		<b>01</b>	BSP Pipe thread ISO 228		
<b>N</b>	Dog (Tang)		<b>M</b>		<b>O</b>	Square flange Pilot Ø 36.47 mm		<b>30</b>	Rectangular flange		
<b>A</b>	Cylindrical (Straight key) ISO Ø 18mm		<b>B</b>		<b>C</b>	SAE B 2-bolt		<b>07</b>	Split flange SAE Code 61 Metric bolts		
<b>Q</b>	Cylindrical (Straight key) SAE A 5/8"		<b>R</b>		<b>M</b>	Transmission flange Pilot Ø 52 mm with O-ring		<b>40</b>	Split flange SAE Code 61 UNC bolts		
<b>Q</b>	SAE 3/4" Keyed, Long *Use S0022 suffix		<b>R</b>		<b>A</b>	Outrigger bearing Pilot Ø 80 mm (outboard bearing)					
<b>R</b>	Spline shaft SAE A 9T		<b>R</b>	<b>C</b>							
<b>P</b>	Spline shaft SAE 11T		<b>R</b>	<b>C</b>							
<b>F</b>	Spline shaft DIN 5482 B17x14		<b>B</b>	<b>P</b>							

\* Common SO Codes:  
S0022 – Long keyed shaft  
Contact Factory for additional codes.

Size **F**  
4 ... 28 cm<sup>3</sup>/rev

## F Series Pump Product Index

(Reference page 14 for ordering code designators)

AZPF-XX-XXXX - - MB

Page Number	Ordering code	Shaft Type	Flange	Mounting Ports	Port Orientation
23	AZPF-XX-XXXXRR12MB	R	R	12	side
24	AZPF-XX-XXXXRR12MA	R	R	12	rear
25	AZPF-XX-XXXXQR12MB	Q	R	12	side
26	AZPF-XX-XXXXQR12MA	Q	R	12	rear
27	AZPF-XX-XXXXPR12MB	P	R	12	side
28	AZPF-XX-XXXXQR12MB-S0022	Q-long	R	12	side
29	AZPF-XX-XXXXQR12MA-S0022	Q-long	R	12	rear
30	AZPF-XX-XXXXPC12MB	P	C	12	side
31	AZPF-XX-XXXXRR20MB	R	R	20	side
32	AZPF-XX-XXXXCB20MB	C	B	20	side
33	AZPF-XX-XXXXFB20MB	F	B	20	side
34	AZPF-XX-XXXXHO30MB	H	O	30	side
35	AZPF-XX-XXXXFO30MB	F	O	30	side
36	AZPF-XX-XXXXHO01MB	H	O	01	side
37	AZPF-XX-XXXXCN20MB	C	N	20	side
38	AZPF-XX-XXXXFN20MB	F	N	20	side
39	AZPF-XX-XXXXCP20MB-S0007	C	P	20	side
40	AZPF-XX-XXXXFP20PB	F	P	20	side
41	AZPF-XX-XXXXNT20MB	N	T	20	side
42	AZPF-XX-XXXXSA20MB	S	A	20	side
43	AZPF-XX-XXXXSG20MB	S	G	20	side

F Series Drive Shafts

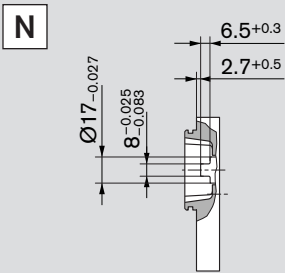
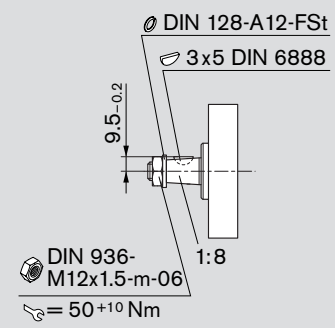
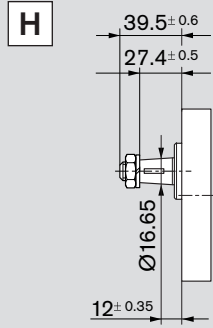
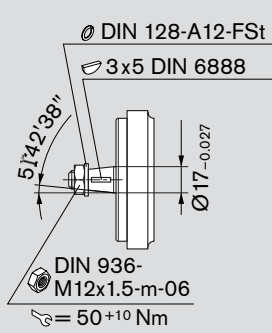
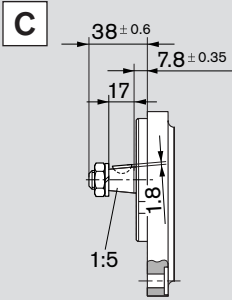

Pump without shaft seal, see page 14

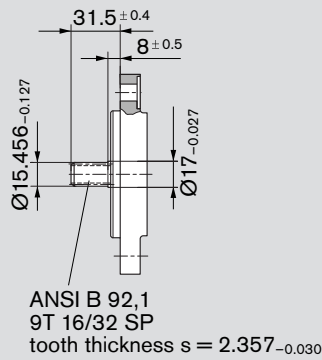
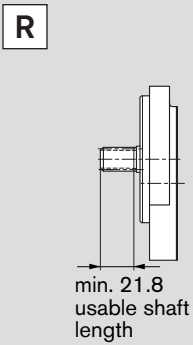
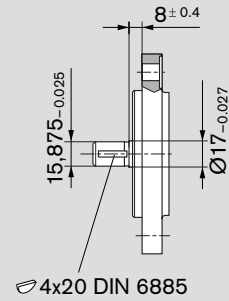
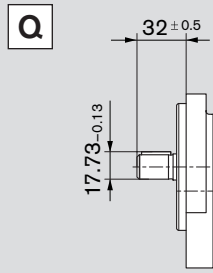

**Q** w/ S0022 Elongated Shaft

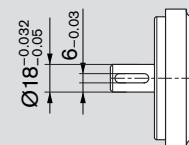
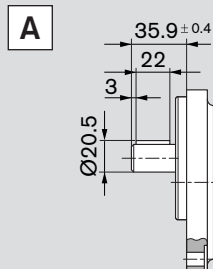
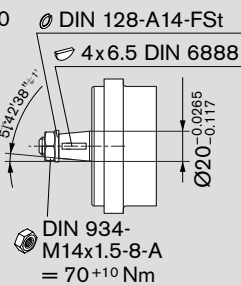
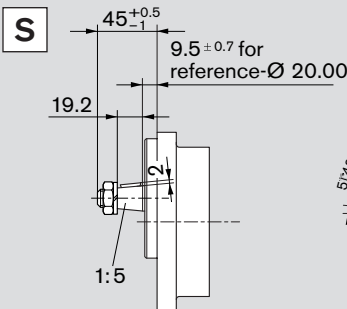
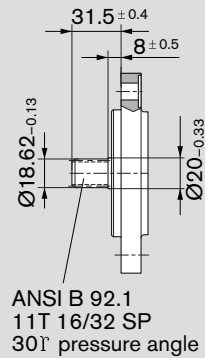
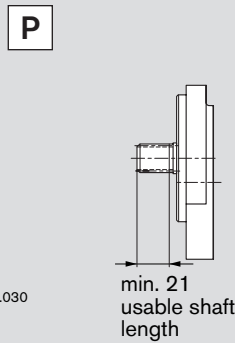
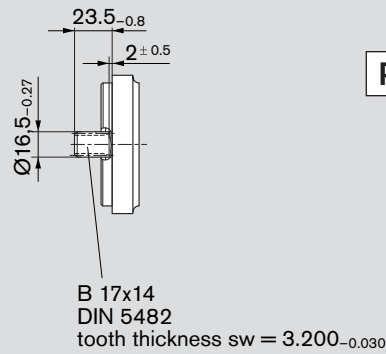
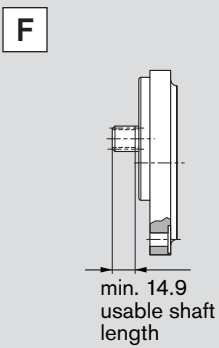
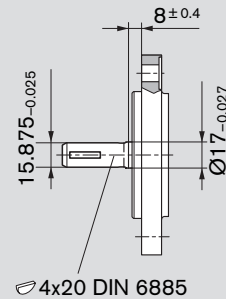
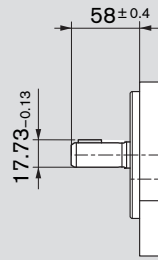



F Series Front Cover

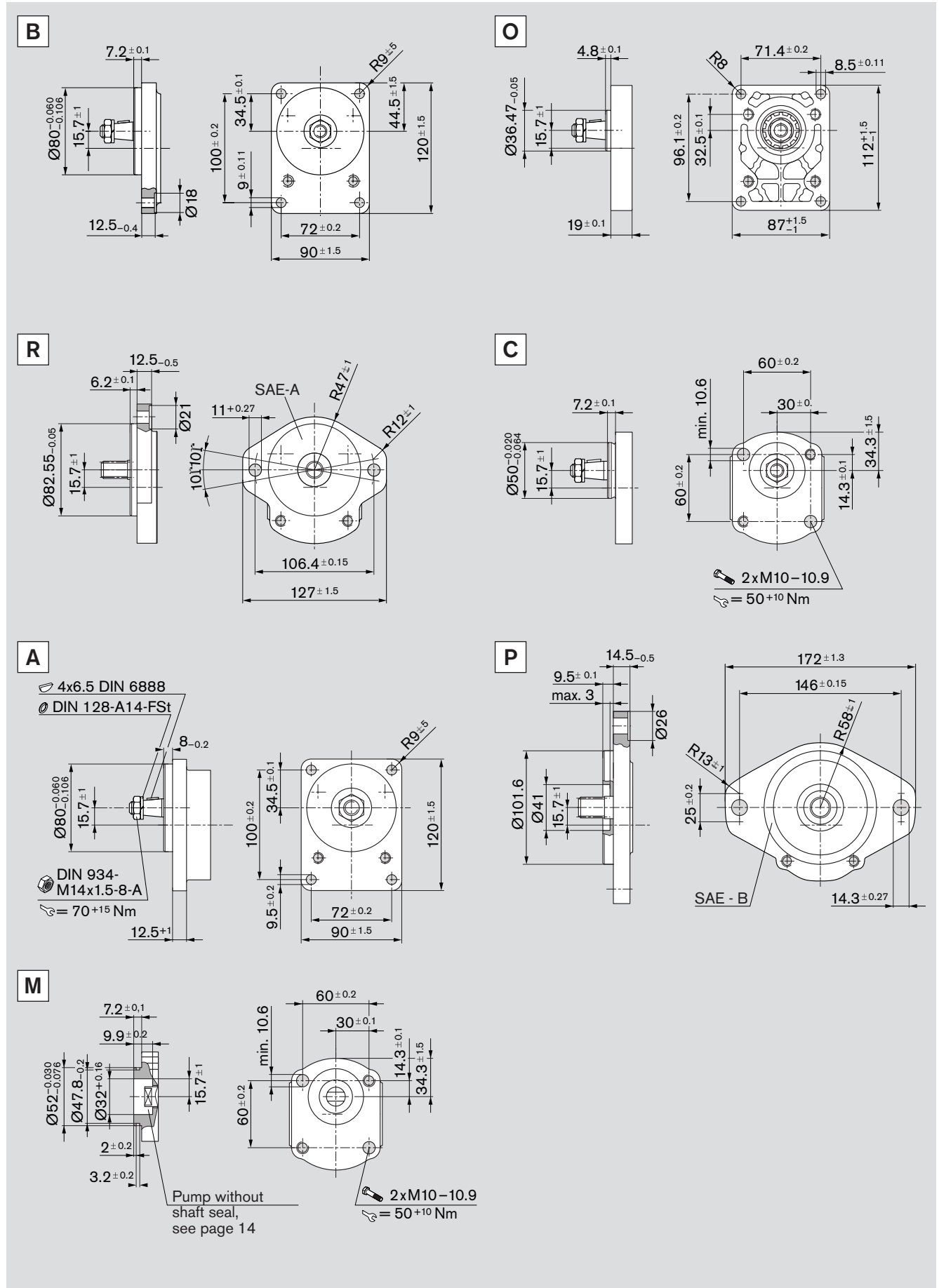

### F Series Port Connections

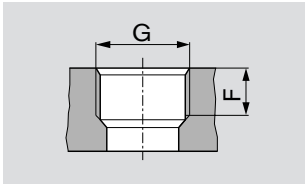

**01** Pipe thread  
ISO 228/1

when pressure  $p_2 > 210$  bar  
limited fatigue strength

Synopsis of Types	Size	Pressure port		Suction port	
		G	F	G	F
01	4 ... 16 cm <sup>3</sup>	G 1/2	16	G 3/4	16
	19 ... 28 cm <sup>3</sup>	G 3/4		G1	19

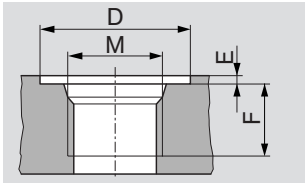

**03** Thread metric  
ISO 6149  
with O-ring

when pressure  $p_2 > 210$  bar  
limited fatigue strength

Synopsis of Types	Size	Pressure port				Suction port			
		M	D	E	F	M	D	E	F
03	4 ... 5.5 cm <sup>3</sup>	M 18 x 1.5	29	0.5	14.5	M 18 x 1.5	29	0.5	14.5
	8 ... 16 cm <sup>3</sup>	M 22 x 1.5	34			18	M 27 x 1.5		
	19 ... 28 cm <sup>3</sup>					M 33 x 1.5	46		22

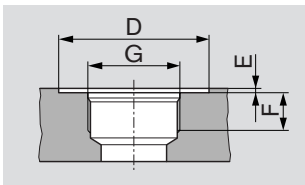

**12** Thread  
(UN-2B) SAE  
O-ring BOSS

when pressure  $p_2 > 210$  bar  
limited fatigue strength

Synopsis of Types	Size	Pressure port				Suction port			
		G	D	E	F	G	D	E	F
12	4 ... 5.5 cm <sup>3</sup>	SAE - 8	25	0.5	13	SAE - 10	25	0.5	13
	8 ... 14 cm <sup>3</sup>	SAE - 10	35			16	SAE - 12		
	16 ... 28 cm <sup>3</sup>	SAE - 10				SAE - 16	45		19

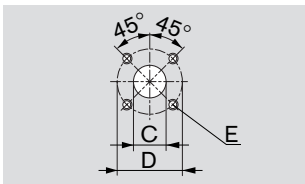

**20** Rectangular flange  
DIN 8901/8902

Synopsis of Type	Size	Pressure port			Suction port		
		C	D	E	C	D	E
20	4 ... 5.5 cm <sup>3</sup>	15	35	M 6 depth 13	15	40	M 6 depth 13
	20						
	19 ... 28 cm <sup>3</sup>	26	55	M 8 depth 13			

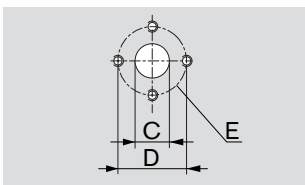

**30** Rectangular flange

Synopsis of Type	Size	Pressure port			Suction port		
		C	D	E	C	D	E
30	4 ... 8 cm <sup>3</sup>	13.5	30.2	M 6 depth 13	13.5	30.2	M 6 depth 13
	20.0				39.7		M 8 depth 13

**F Series Performance Ratings**

Size		004	005	008	011	014	016	019	022	025	028
Displacement	cm <sup>3</sup> /rev	4.1	5.6	8.2	11.3	14.3	16.5	19.5	22.9	25.4	28.5
Inlet pressure	bar	min. 0.7 max. 3 (absolute)									
max. continuous pressure p <sub>1</sub>	bar	250						210	180	200	170
	psi	3625						3045	2610	2900	2465
max. intermittent pressure p <sub>2</sub>	bar	280						230	210	220	190
	psi	4060						3335	3045	3190	2755
max. peak pressure p <sub>3</sub>	bar	300						250	230	240	210
	psi	4350						3625	3335	3528	3045
min. rotational speed (RPM) ≤ 100	RPM	600	500	500	500	500	500	500	500	500	500
max. rotational speed at (RPM)	p <sub>1</sub>	3500			3000	2500	2000	2000	2000	2000	2000
	p <sub>2</sub>	4000			3500	3500	3500	3000	2750	2500	2500

**F Series Pumps**

**SAE O-Ring BOSS - Standard Porting**

Displacement (cc)	Side Ports		Rear Port	
	Inlet	Outlet	Inlet	Outlet
4	-10	-8	-12	-10
5	-10	-8	-12	-10
8	-12	-10	-12	-10
11	-12	-10	-12	-10
14	-12	-10	-12	-10
16	-16	-10	-12	-10
19	-16	-10	-12	-10
22	-16	-10	-12	-10
25	-16	-10	-12	-10
28	-16	-10	-12	-10

**SAE Porting - Specifications and Dimensions per SAE J1926/1**

Dash Size	Thread Size (in)
-2	5/16-24 UNF-2B
-3	3/8-24 UNF-2B
-4	7/16-20 UNF-2B
-5	1/2-20 UNF-2B
-6	9/16-18 UNF-2B
-8	3/4-16 UNF-2B
-10	7/8-14 UNF-2B
-12	1-1/16-12 UN-2B
-14	1-3/16-12 UN-2B
-16	1-5/16-12 UN-2B
-20	1-5/8-12 UN-2B
-24	1-7/8-12 UN-2B
-32	2-1/2-12 UN-2B

Note: Ratings represent units incorporating SAE O-Ring BOSS threaded ports. Pressure ratings may differ for other types of ports.

**Diagrams**

Size **F**

$\nu = 35 \text{ mm}^2/\text{s}, T = 50 \text{ }^\circ\text{C}$

**Unit Conversions**

- Pressure:  $\text{psi} = \text{bar} \times 14.7$
- Torque:  $\text{ft-lbs} = (\text{Nm}) \times .738$
- Power:  $\text{hp} = (\text{kW}) \times 1.341$
- Volume:  $\text{in}^3 = (\text{cc}) \times 16.39$
- $\text{gpm} = (\text{LPM}) \times .2642$

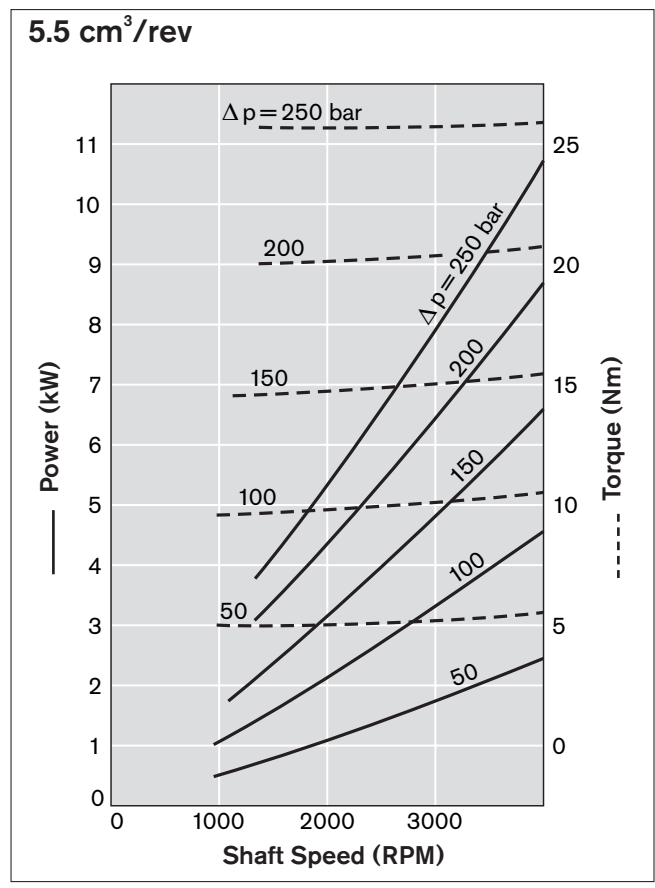
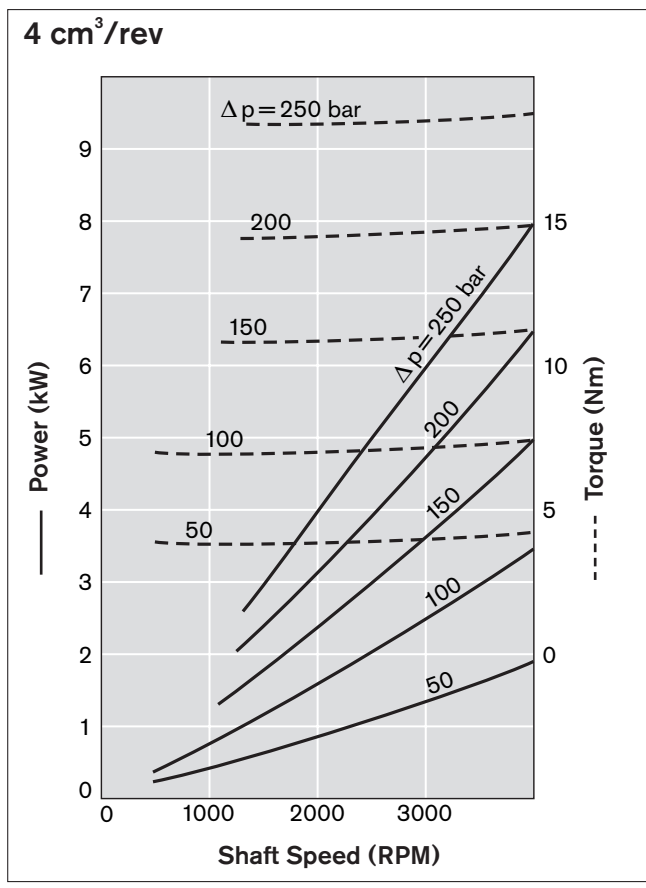
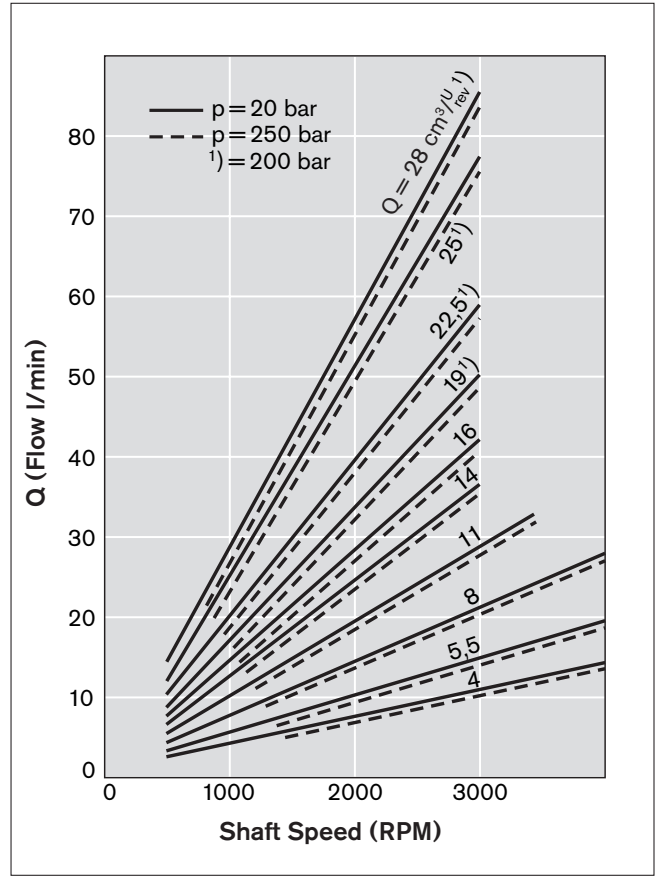

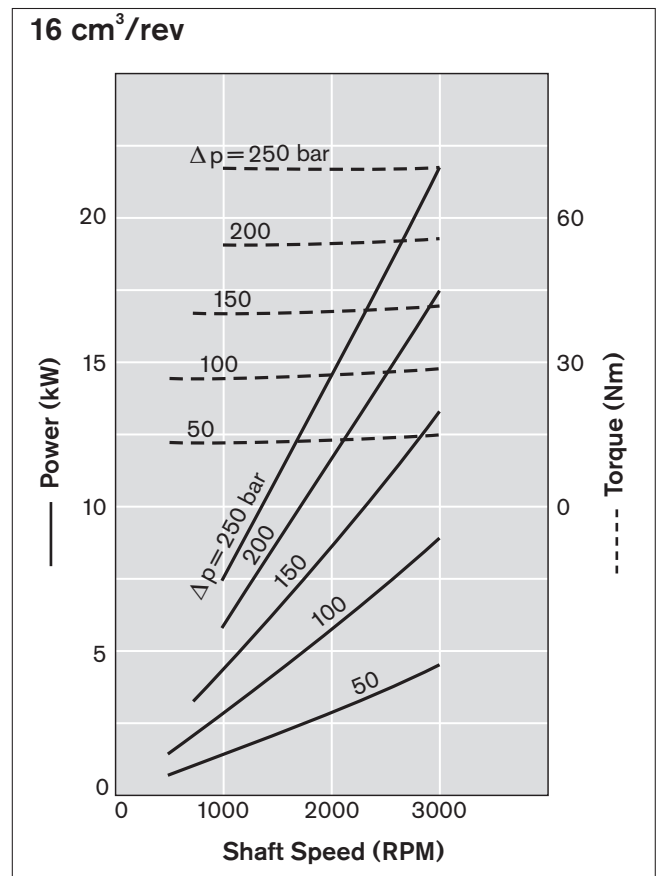
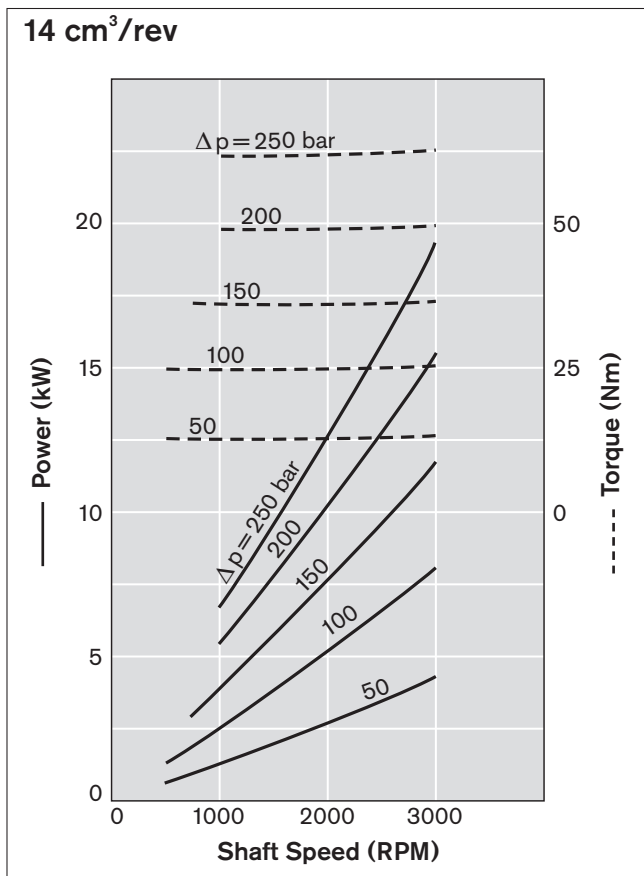
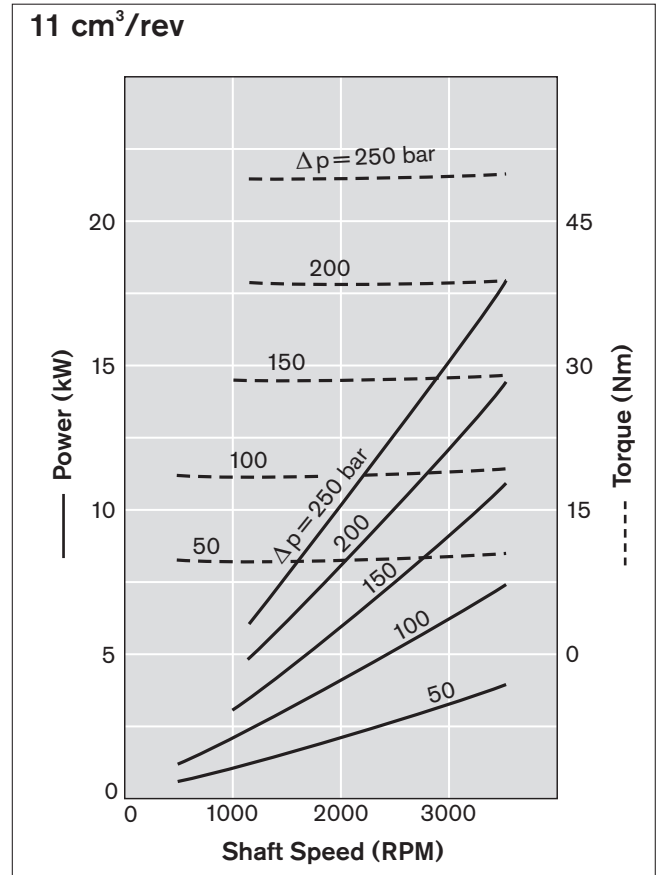
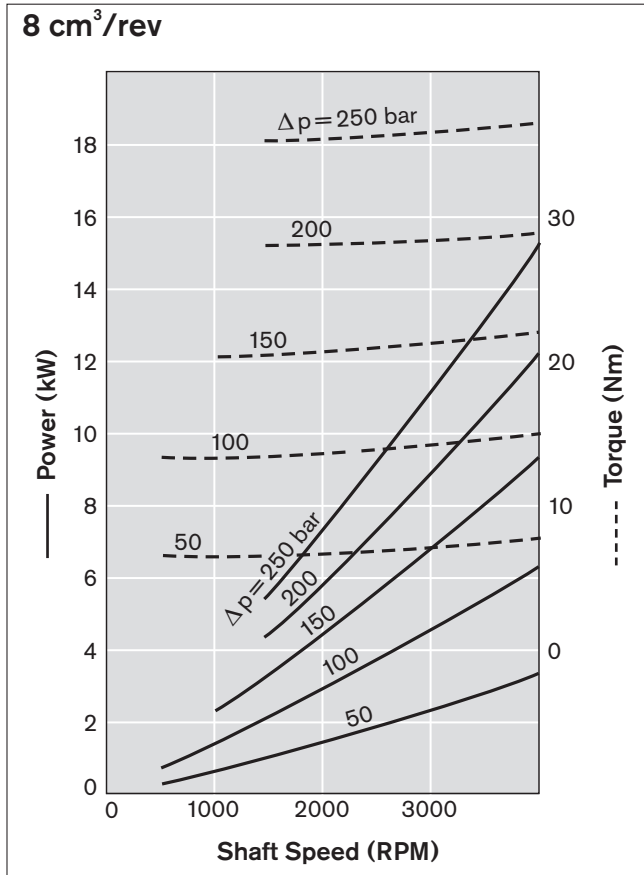

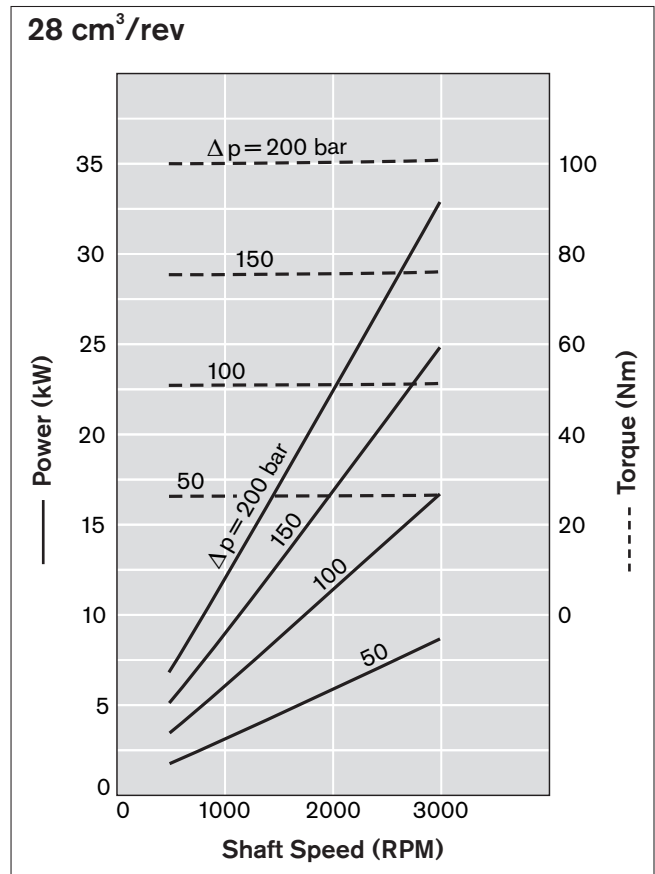
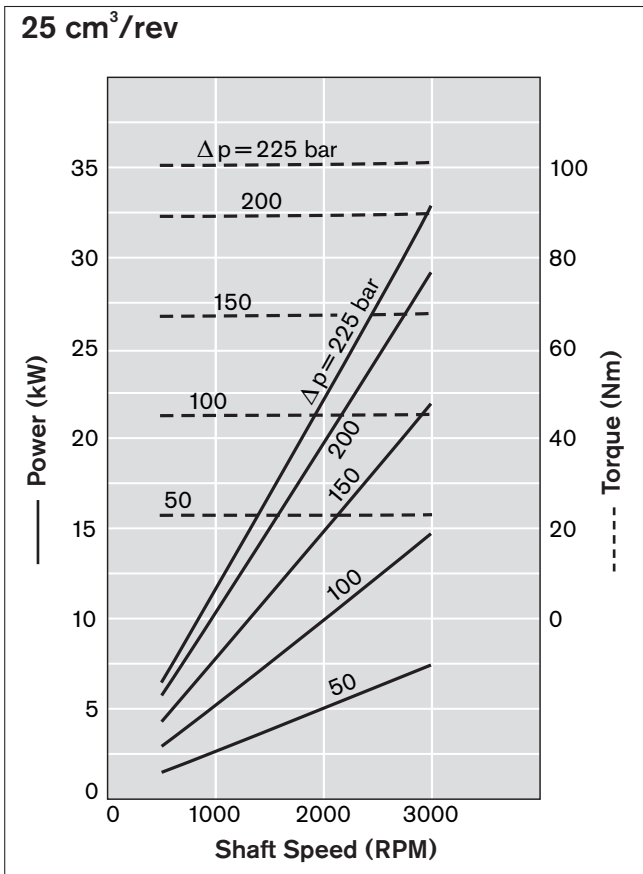
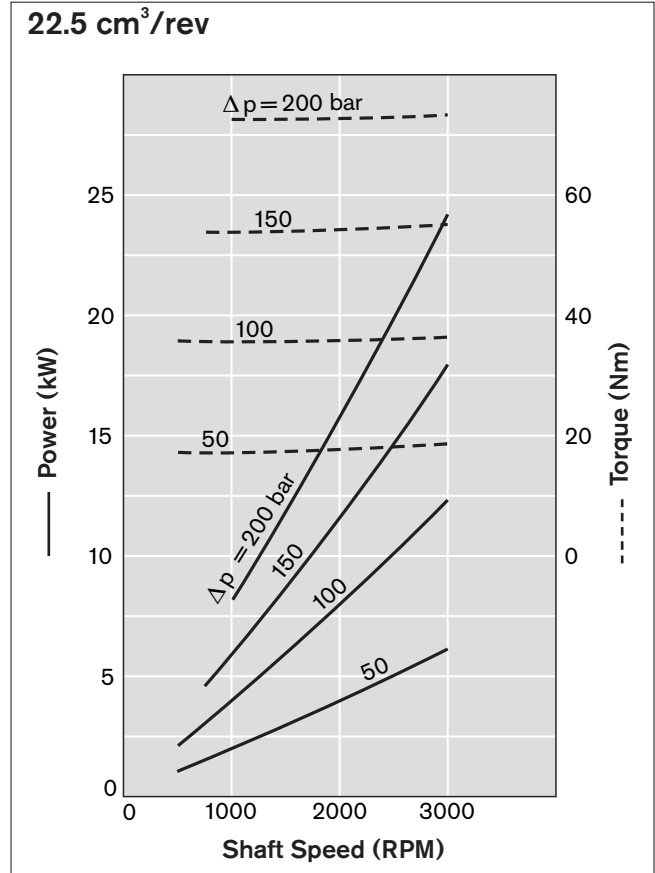
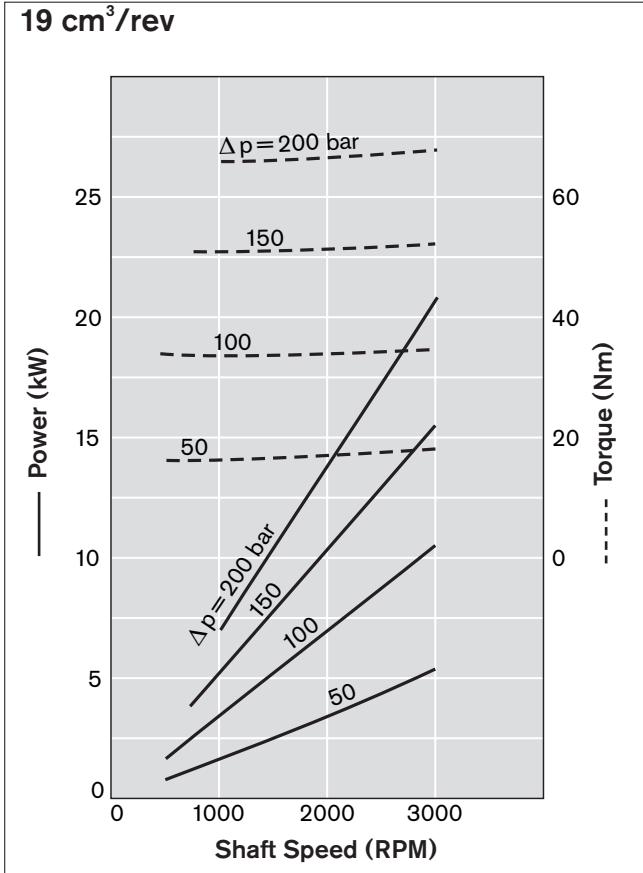

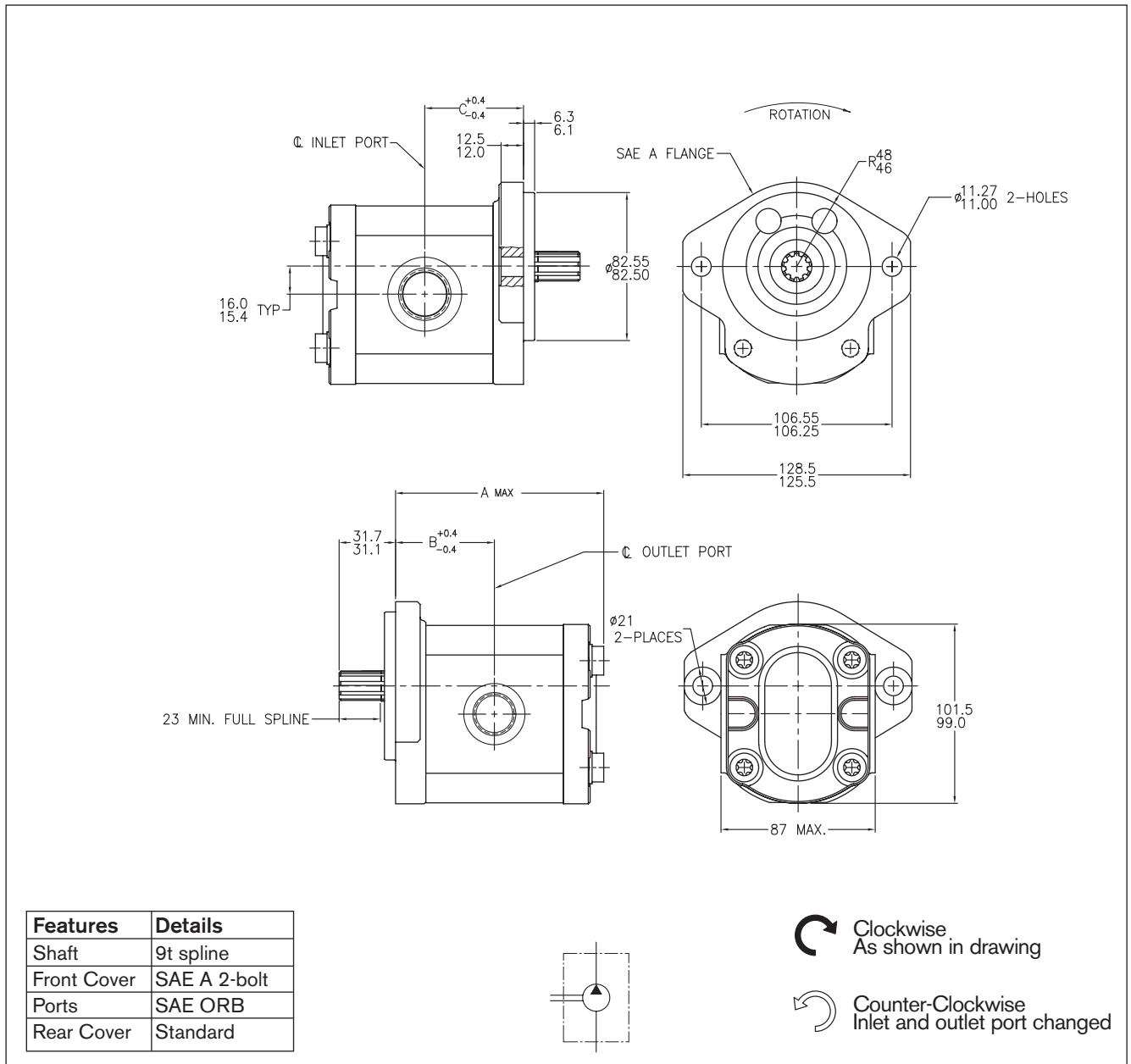

**Ordering code**

**AZPF - X X - □ □ □ □ R R 12 MB**

Displacement [cm <sup>3</sup> /rev]	Ordering-Number *		Max. operating pressure [bar]	Max. rotation speed [min <sup>-1</sup> ]	Dimension [mm]			Inlet Port ** (SAE O-Ring BOSS)	Outlet Port (SAE O-Ring BOSS)
	L	R			A	B	C		
4.0	9 510 290 036	9 510 290 015	250	4000	85.0	39.9	39.9	-10	-8
5.5	9 510 290 037	9 510 290 005	250	4000	85.6	41.1	41.1	-10	-8
8.0	9 510 290 038	9 510 290 017	250	4000	91.6	43.2	43.2	-12	-10
11.0	9 510 290 039	9 510 290 018	250	3500	96.6	47.0	47.0	-12	-10
14.0	9 510 290 040	9 510 290 004	250	3000	101.8	47.5	47.5	-12	-10
16.0	9 510 290 127	9 510 290 056	250	3000	105.0	47.5	47.5	-16	-10
19.0	9 510 290 128	9 510 290 125	210	3000	110.0	47.5	47.5	-16	-10
22.5	9 510 290 129	9 510 290 126	180	2500	115.4	55.1	55.1	-16	-10
25.0	9 510 290 117	9 510 290 111	200	3000	131.6	63.2	63.2	-16	-10
28.0	9 510 290 120	9 510 290 114	170	3000	136.4	65.6	65.6	-16	-10

\* Contact factory for availability of units with no ordering number listed.

\*\* Refer to page 19 for SAE O-Ring Boss Specifications and Dimensions.

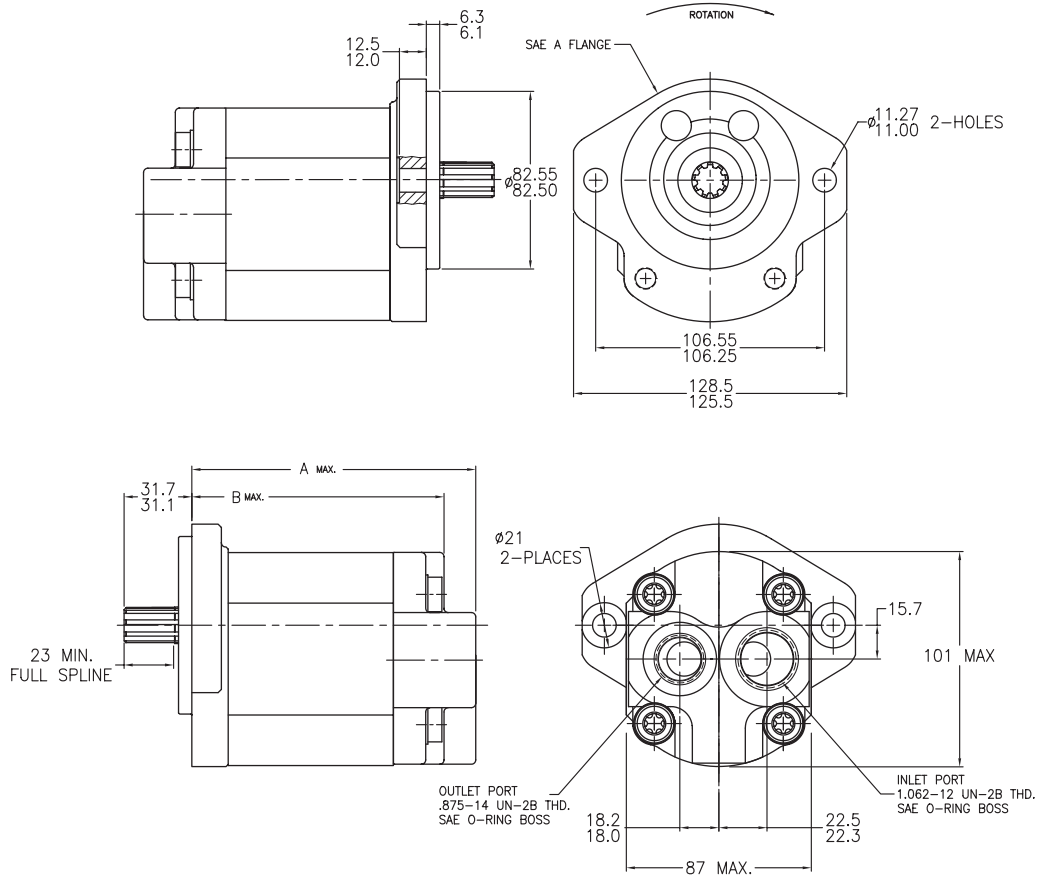

Features	Details
Shaft	9t spline
Front Cover	SAE A 2-bolt
Ports	SAE ORB
Rear Cover	Rear ports

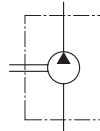

Clockwise  
As shown in drawing

Counter-Clockwise  
Inlet and outlet port changed

**Ordering code**

**AZPF - 12 - □□□ R R 12 MA**

Displacement [cm <sup>3</sup> /rev]	Ordering-Number *		Max. operating pressure [bar]	Max. rotation speed [min <sup>-1</sup> ]	Dimension [mm]			Inlet Port ** (SAE O-Ring BOSS)	Outlet Port (SAE O-Ring BOSS)
	L	R			A	B	C		
4.0	9 510 290 083	9 510 290 075	250	4000	100.3	85.0		-12	-10
5.5	9 510 290 084	9 510 290 076	250	4000	103.3	88.4		-12	-10
8.0	9 510 290 085	9 510 290 077	250	4000	107.4	92.5		-12	-10
11.0	9 510 290 086	9 510 290 078	250	3500	112.4	97.5		-12	-10
14.0	9 510 290 087	9 510 290 079	250	3000	117.4	102.5		-12	-10
16.0	9 510 290 088	9 510 290 080	250	3000	120.8	105.9		-12	-10
19.0	9 510 290 089	9 510 290 081	210	3000	126.8	110.9		-12	-10
22.5	9 510 290 090	9 510 290 082	180	2500	131.2	116.3		-12	-10
25.0	*	*							
28.0	*	*							

\* Contact factory for availability of units with no ordering number listed.

\*\* Refer to page 19 for SAE O-Ring Boss Specifications and Dimensions.



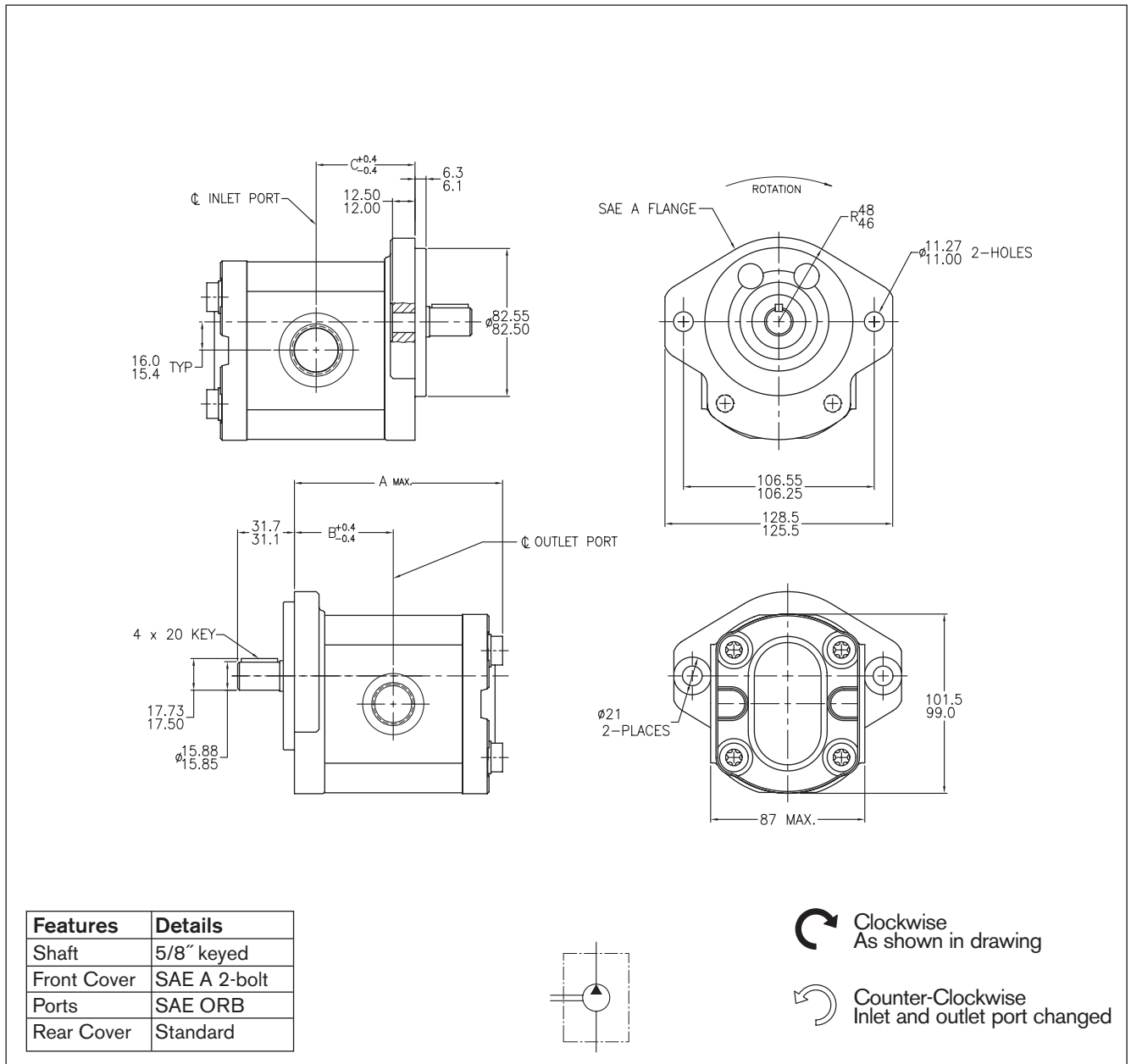

**Ordering code**

**AZPF - 1 2 - □□□□ Q R 12 MB**

Displacement [cm³/rev]	Ordering-Number *		Max. operating pressure [bar]	Max. rotation speed [min⁻¹]	Dimension [mm]			Inlet Port ** (SAE O-Ring BOSS)	Outlet Port (SAE O-Ring BOSS)
	L	R			A	B	C		
4.0	9 510 290 044	9 510 290 021	250	4000	85.0	39.9	39.9	-10	-8
5.5	9 510 290 045	9 510 290 022	250	4000	85.6	41.1	41.1	-10	-8
8.0	9 510 290 046	9 510 290 023	250	4000	91.6	43.2	43.2	-12	-10
11.0	9 510 290 047	9 510 290 024	250	3500	96.6	47.0	47.0	-12	-10
14.0	9 510 290 048	9 510 290 025	250	3000	101.6	47.5	47.5	-12	-10
16.0	9 510 290 130	9 510 290 122	250	3000	105.0	47.5	47.5	-16	-10
19.0	9 510 290 131	9 510 290 123	210	3000	110.0	47.5	47.5	-16	-10
22.5	9 510 290 132	9 510 290 124	180	2500	115.4	55.1	55.1	-16	-10
25.0	9 510 290 118	9 510 290 112	200	3000	131.6	63.2	63.2	-16	-10
28.0	9 510 290 121	9 510 290 115	170	3000	136.4	65.6	65.6	-16	-10

\* Contact factory for availability of units with no ordering number listed.

\*\* Refer to page 19 for SAE O-Ring Boss Specifications and Dimensions.

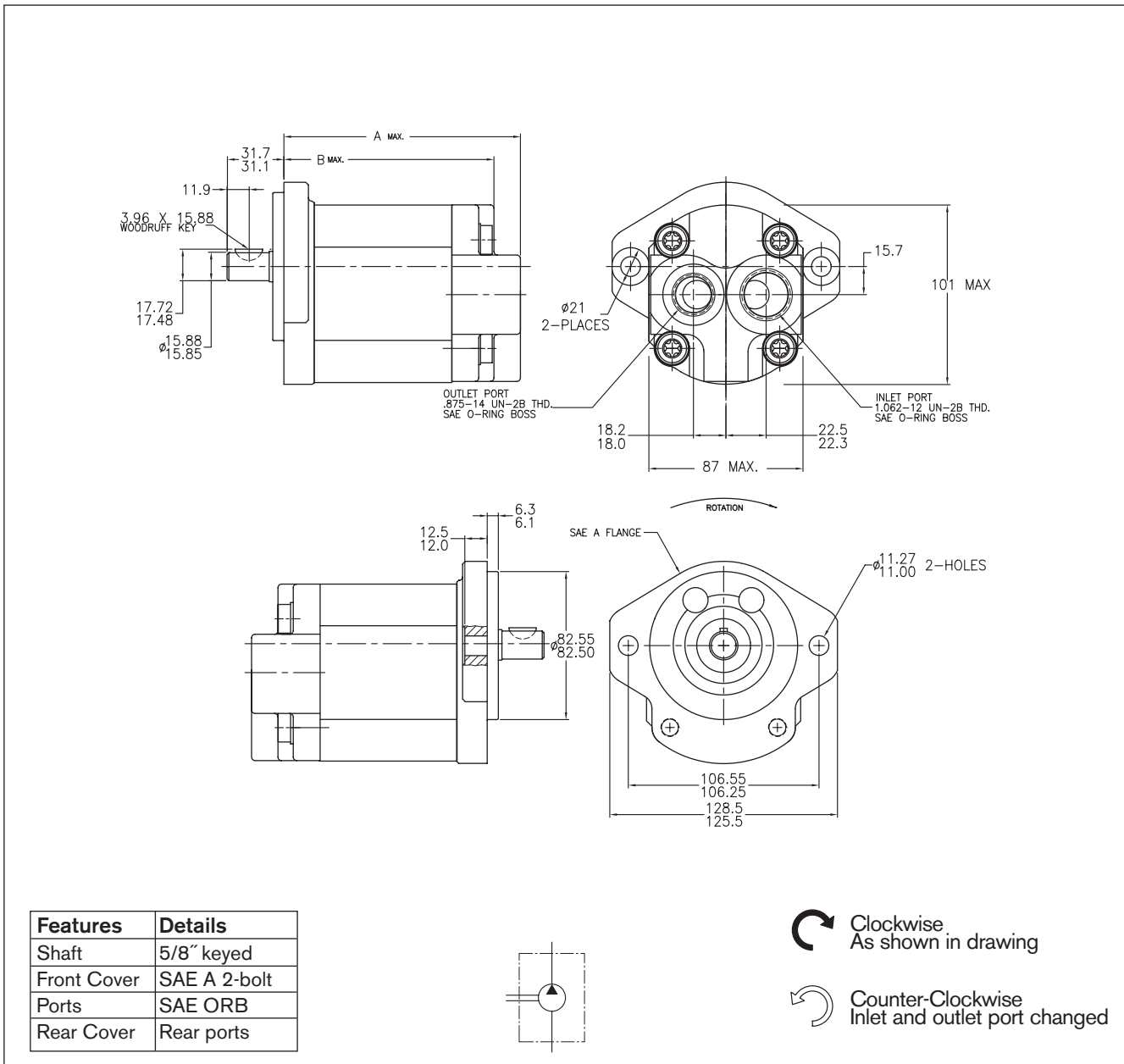

**Ordering code**

AZPF - 1 2 - □□□□ Q R 12 MA

Displacement [cm³/rev]	Ordering-Number *		Max. operating pressure [bar]	Max. rotation speed [min <sup>-1</sup> ]	Dimension [mm]			Inlet Port ** (SAE O-Ring BOSS)	Outlet Port (SAE O-Ring BOSS)
	L	R			A	B	C		
4.0	9 510 290 099	9 510 290 091	250	4000	100.8	85.9		-12	-10
5.5	9 510 290 100	9 510 290 092	250	4000	103.3	88.4		-12	-10
8.0	9 510 290 101	9 510 290 093	250	4000	107.4	92.5		-12	-10
11.0	9 510 290 102	9 510 290 094	250	3500	112.4	97.5		-12	-10
14.0	9 510 290 103	9 510 290 095	250	3000	117.4	102.5		-12	-10
16.0	9 510 290 104	9 510 290 096	250	3000	120.8	105.9		-12	-10
19.0	9 510 290 105	9 510 290 097	210	3000	126.8	110.9		-12	-10
22.5	9 510 290 106	9 510 290 098	180	2500	131.2	116.3		-12	-10
25.0	*	*							
28.0	*	*							

\* Contact factory for availability of units with no ordering number listed.  
 \*\* Refer to page 19 for SAE O-Ring Boss Specifications and Dimensions.

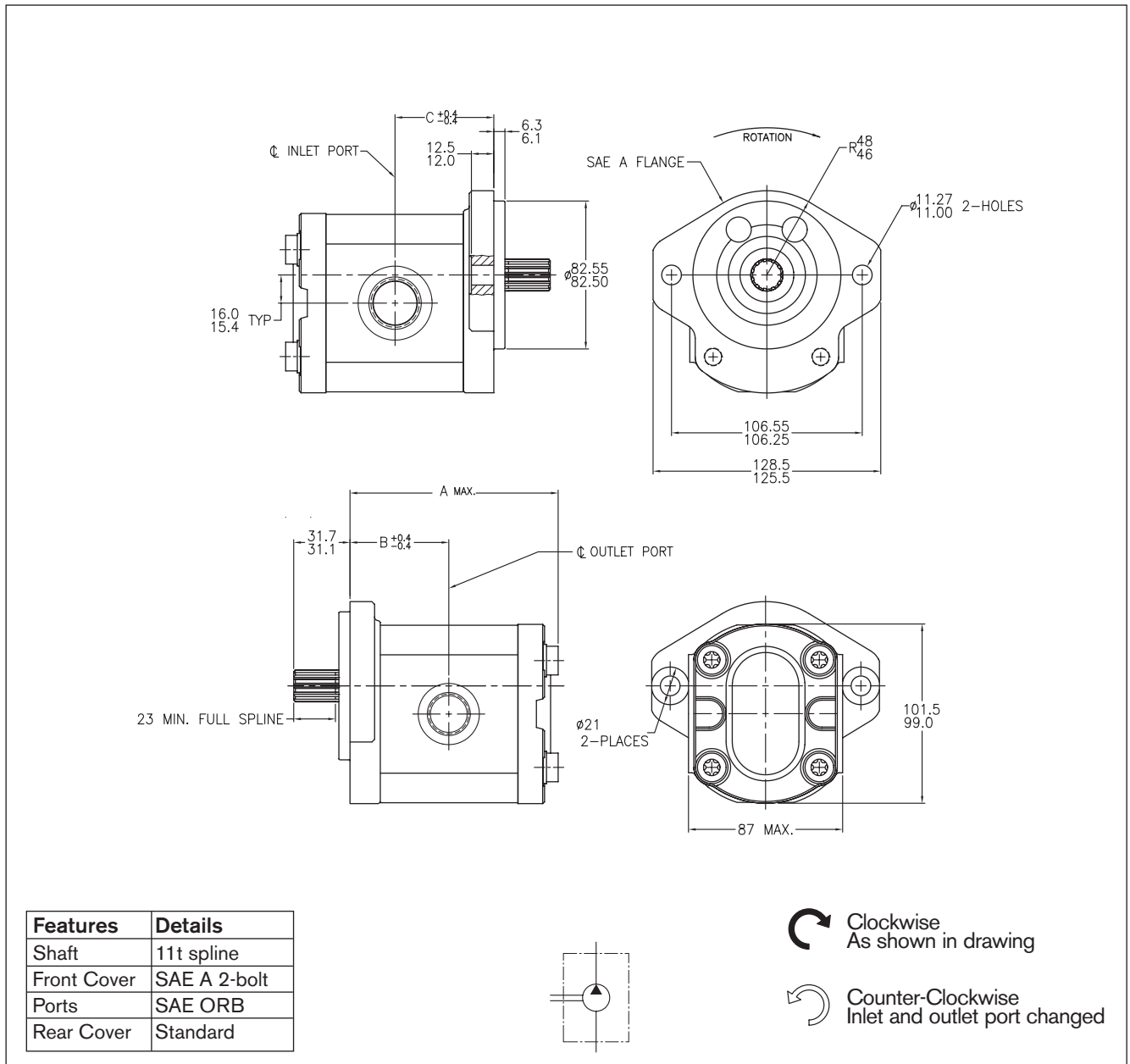

**Ordering code**

**AZPF - 1 2 - □ □ □ □ P R 12 MB**

Displacement [cm <sup>3</sup> /rev]	Ordering-Number *		Max. operating pressure [bar]	Max. rotation speed [min <sup>-1</sup> ]	Dimension [mm]			Inlet Port ** (SAE O-Ring BOSS)	Outlet Port (SAE O-Ring BOSS)
	L	R			A	B	C		
4.0	9 510 290 065	9 510 290 057	250	4000	85.0	40.5	40.5	-10	-8
5.5	9 510 290 066	9 510 290 058	250	4000	85.6	41.1	41.1	-10	-8
8.0	9 510 290 067	9 510 290 059	250	4000	91.6	43.2	43.2	-12	-10
11.0	9 510 290 068	9 510 290 060	250	3500	96.6	47.0	47.0	-12	-10
14.0	9 510 290 069	9 510 290 061	250	3000	101.6	47.5	47.5	-12	-10
16.0	9 510 290 070	9 510 290 062	250	3000	105.0	49.9	49.9	-16	-10
19.0	9 510 290 071	9 510 290 063	210	3000	110.0	52.4	52.4	-16	-10
22.5	9 510 290 072	9 510 290 064	180	2500	115.4	55.1	55.1	-16	-10
25.0	9 510 290 116	9 510 290 110	200	3000	131.6	63.2	63.2	-16	-10
28.0	9 510 290 119	9 510 290 113	170	3000	136.4	65.6	65.6	-16	-10

\* Contact factory for availability of units with no ordering number listed.

\*\* Refer to page 19 for SAE O-Ring Boss Specifications and Dimensions.

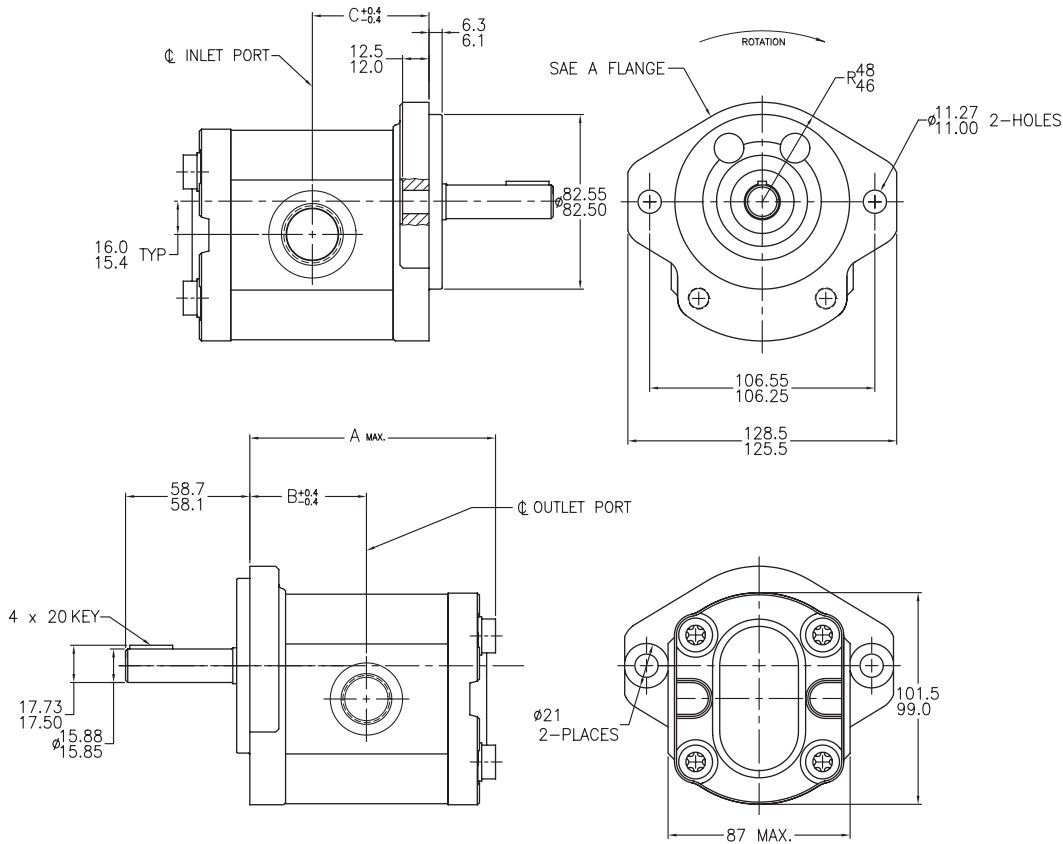

Features	Details
Shaft	5/8" keyed - long
Front Cover	SAE A 2-bolt
Ports	SAE ORB
Rear Cover	Standard

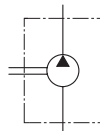

Clockwise  
As shown in drawing

Counter-Clockwise  
Inlet and outlet port changed

**Ordering code**

**AZPF - 1 2 - □□□□ Q R 12 MB - S0022**

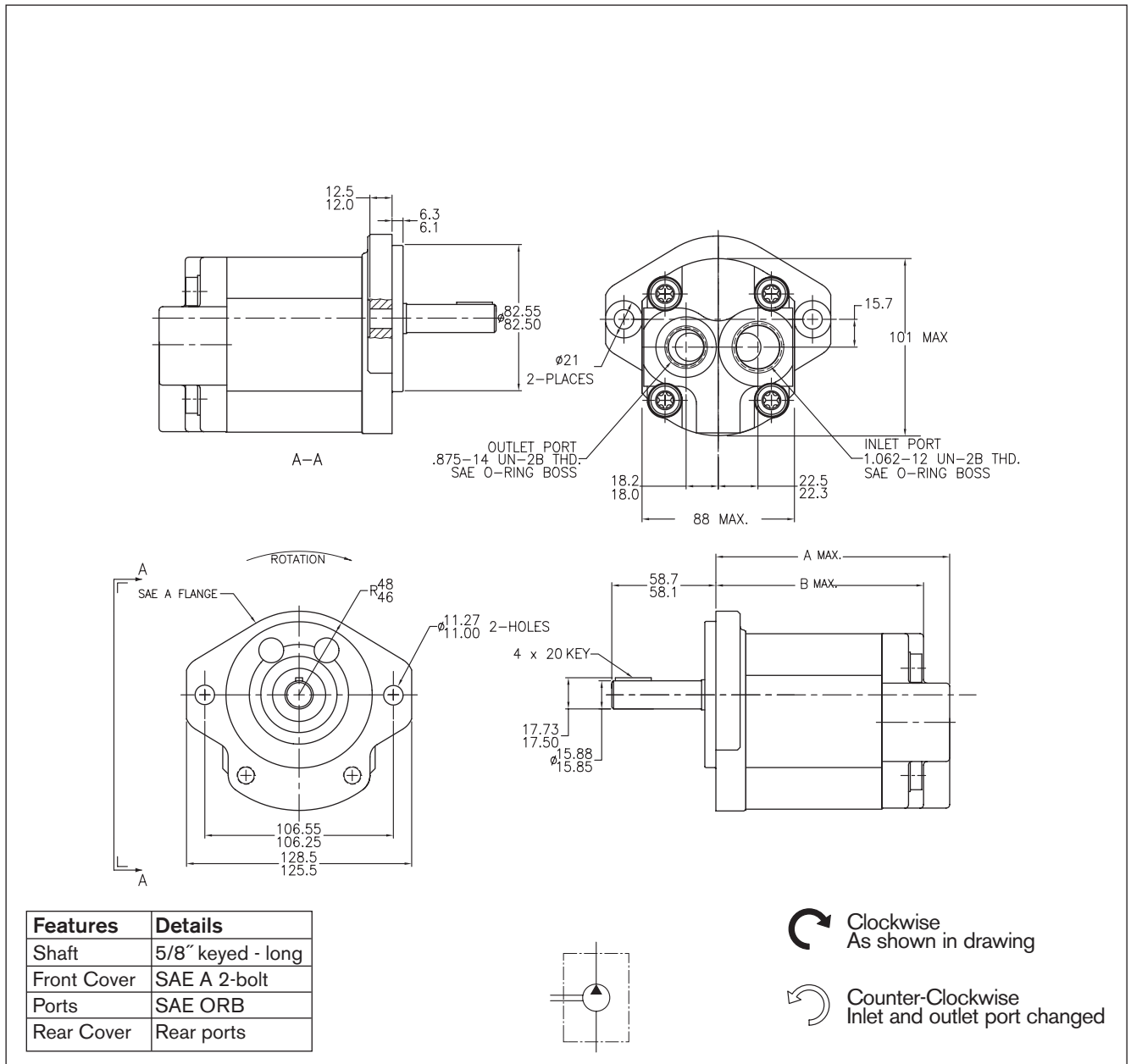

Displacement [cm <sup>3</sup> /rev]	Ordering-Number *		Max. operating pressure [bar]	Max. rotation speed [min <sup>-1</sup> ]	Dimension [mm]			Inlet Port ** (SAE O-Ring BOSS)	Outlet Port (SAE O-Ring BOSS)
	L	R			A	B	C		
4.0	*	*							
5.5	*	<b>9 510 290 259</b>	250	4000	85.6	41.1	41.1	-10	-8
8.0	<b>9 510 290 214</b>	<b>9 510 290 191</b>	250	4000	91.6	43.2	43.2	-12	-10
11.0	<b>9 510 290 254</b>	<b>9 510 290 209</b>	250	3500	96.6	47.0	47.0	-12	-10
14.0	<b>9 510 290 215</b>	<b>9 510 290 133</b>	250	3000	101.6	47.5	47.5	-12	-10
16.0	<b>9 510 290 255</b>	<b>9 510 290 210</b>	250	3000	105.0	49.9	49.9	-16	-10
19.0	<b>9 510 290 256</b>	<b>9 510 290 211</b>	210	3000	110.0	52.4	52.4	-16	-10
22.5	<b>9 510 290 257</b>	<b>9 510 290 212</b>	180	2500	115.4	55.1	55.1	-16	-10
25.0	*	*							
28.0	*	*							

\* Contact factory for availability of units with no ordering number listed.  
 \*\* Refer to page 19 for SAE O-Ring Boss Specifications and Dimensions.



**Ordering code**

**AZPF - 1 2 - □□□□ Q R 12 MA - S0022**

Displacement [cm <sup>3</sup> /rev]	Ordering-Number *		Max. operating pressure [bar]	Max. rotation speed [min <sup>-1</sup> ]	Dimension [mm]			Inlet Port ** (SAE O-Ring BOSS)	Outlet Port (SAE O-Ring BOSS)
	 L	 R			A	B	C		
4.0	*	*							
5.5	*	*							
8.0	*	*							
11.0	*	<b>9 510 290 134</b>	250	3500	112.4	97.5		-12	-10
14.0	*	*							
16.0	*	*							
19.0	<b>9 510 290 135</b>	<b>9 510 290 213</b>	210	3000	125.8	110.9		-12	-10
22.5	*	*							
25.0	*	*							
28.0	*	*							

\* Contact factory for availability of units with no ordering number listed.

\*\* Refer to page 19 for SAE O-Ring Boss Specifications and Dimensions.

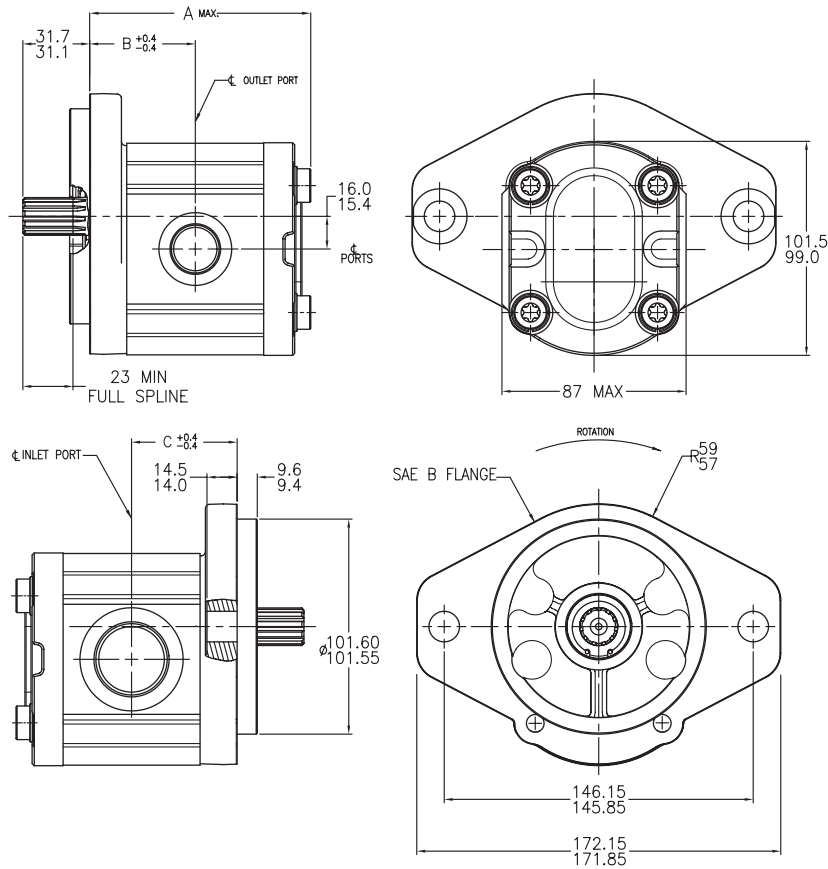

Features	Details
Shaft	11t spline
Front Cover	SAE B 2-bolt
Ports	SAE ORB
Rear Cover	Standard

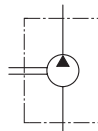

Clockwise  
As shown in drawing

Counter-Clockwise  
Inlet and outlet port changed

**Ordering code**

**AZPF - 1 2 - □ □ □ □ P C 12 MB**

Displacement [cm <sup>3</sup> /rev]	Ordering-Number *		Max. operating pressure [bar]	Max. rotation speed [min <sup>-1</sup> ]	Dimension [mm]			Inlet Port ** (SAE O-Ring BOSS)	Outlet Port (SAE O-Ring BOSS)
	L	R			A	B	C		
4.0	*	<b>9 510 290 323</b>	250	4000	85.0	40.5	40.5	-10	-8
5.5	*	<b>9 510 290 324</b>	250	4000	85.0	41.1	41.1	-10	-10
8.0	*	<b>9 510 290 325</b>	250	4000	91.6	43.2	43.2	-12	-10
11.0	*	<b>9 510 290 326</b>	250	3500	96.6	47.0	47.0	-12	-10
14.0	*	<b>9 510 290 327</b>	250	3000	101.6	47.5	47.5	-12	-10
16.0	*	<b>9 510 290 328</b>	250	3000	105.0	49.9	49.9	-16	-10
19.0	*	<b>9 510 290 329</b>	210	3000	110.0	52.4	52.4	-16	-10
22.5	*	<b>9 510 290 330</b>	180	2500	115.4	55.1	55.1	-16	-10
25.0	*	<b>9 510 290 331</b>	200	3000	131.6	63.2	63.2	-16	-10
28.0	*	<b>9 510 290 332</b>	170	3000	136.4	65.6	65.6	-16	-10

\* Contact factory for availability of units with no ordering number listed.

\*\* Refer to page 19 for SAE O-Ring Boss Specifications and Dimensions.

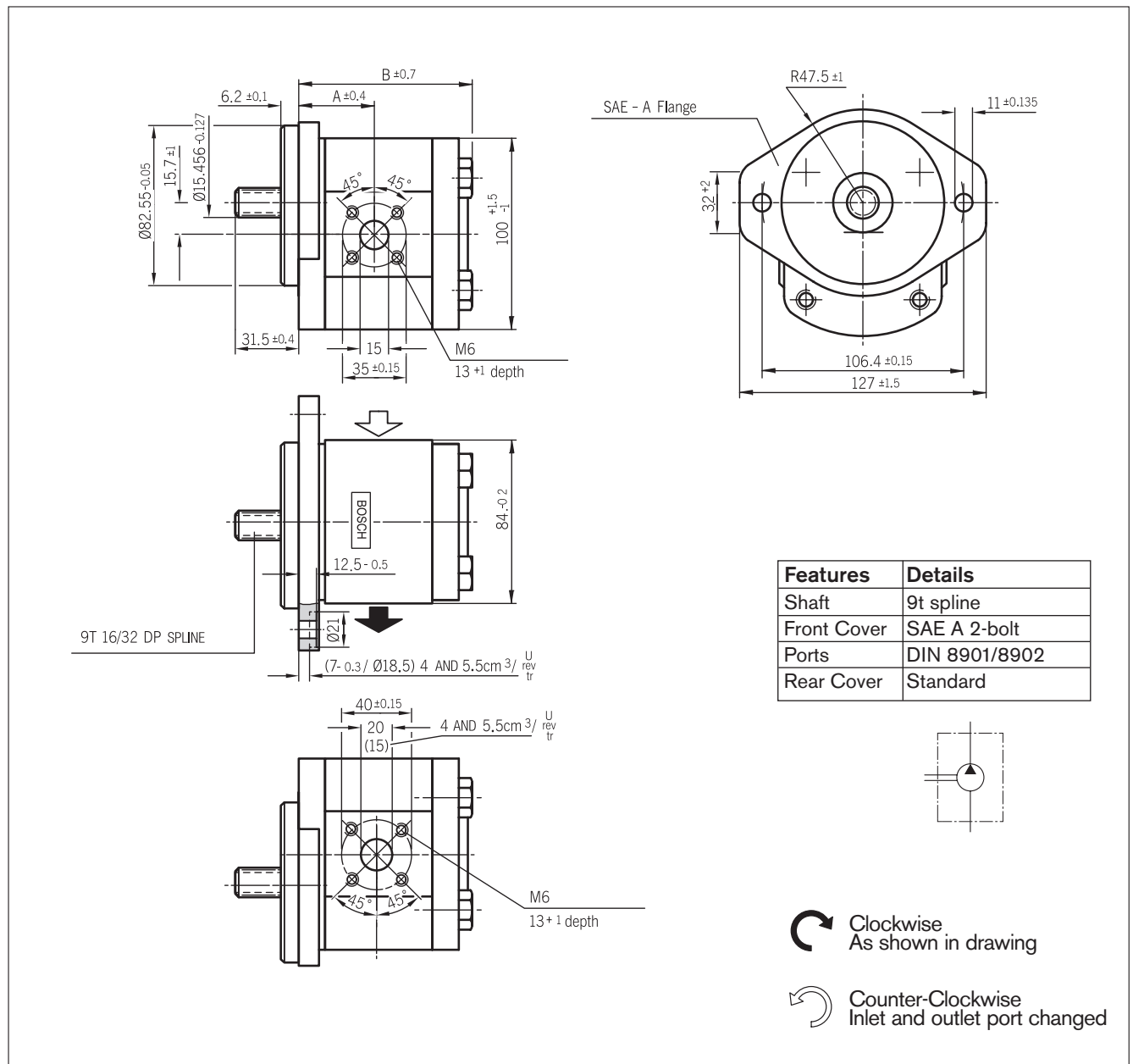

**Ordering code**

**AZPF - 1 2 - □□□□ R R 20 MB**

Displacement [cm <sup>3</sup> /rev]	Ordering-Number *		Max. operating pressure [bar]	Max. rotation speed [min <sup>-1</sup> ]	Dimension [mm]				
	L	R			A	B			
4.0	0 510 225 314	0 510 225 013	250	4000	39.9	85.0			
5.5	0 510 325 313	0 510 325 013	250	4000	41.1	87.5			
8.0	0 510 425 314	0 510 425 020	250	4000	43.2	91.6			
11.0	0 510 525 324	0 510 525 019	250	3500	47.0	96.6			
14.0	0 510 525 325	0 510 525 020	250	3000	47.5	101.6			
16.0	0 510 625 329	0 510 625 028	250	3000	47.5	105.0			
19.0	0 510 625 330	0 510 625 029	210	3000	47.5	110.0			
22.5	0 510 725 361	0 510 725 077	180	2500	55.1	115.4			
25.0									
28.0									

\* Contact factory for availability of units with no ordering number listed.

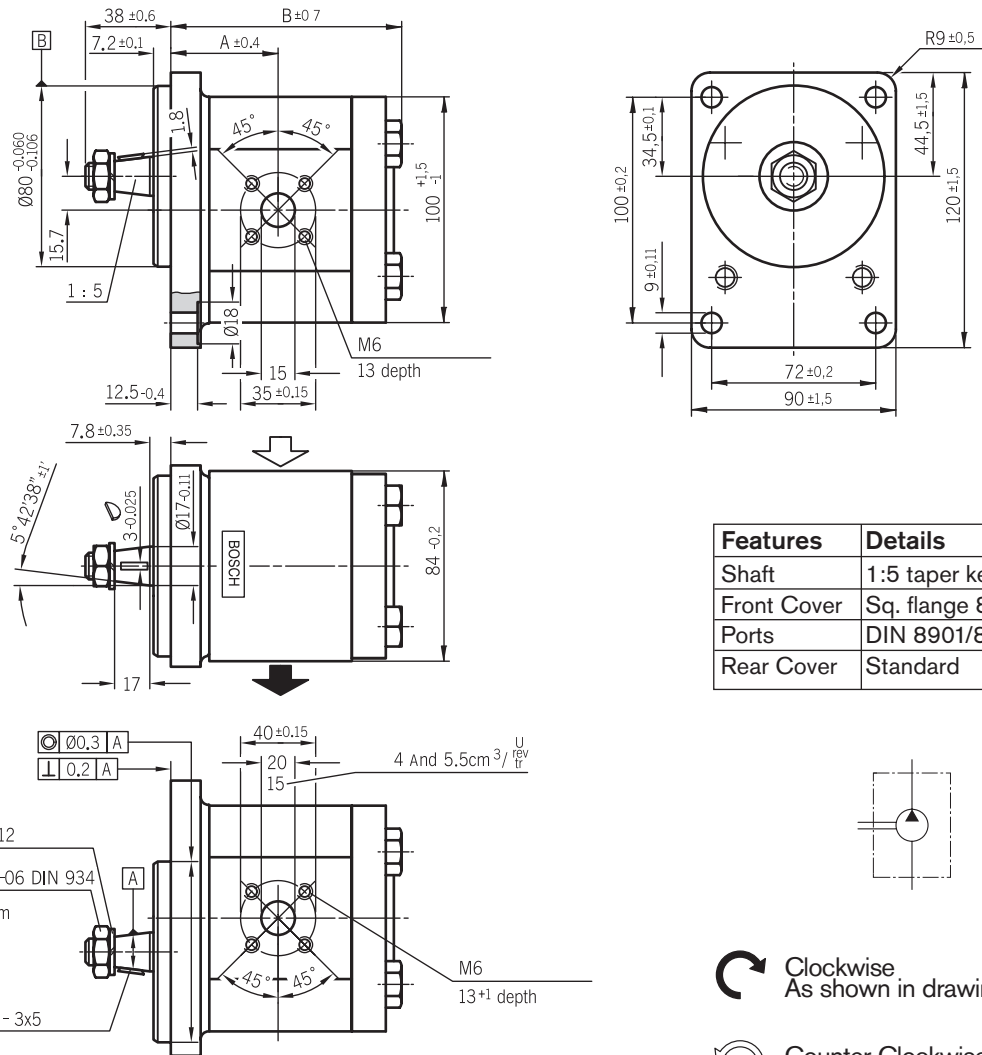

Features	Details
Shaft	1:5 taper keyed
Front Cover	Sq. flange 80mm
Ports	DIN 8901/8902
Rear Cover	Standard

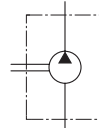

Clockwise  
As shown in drawing

Counter-Clockwise  
Inlet and outlet port changed

**Ordering code**  
AZPF - X X - □ □ □ □ C B 20 MB

Displacement [cm <sup>3</sup> /rev]	Ordering-Number *		Max. operating pressure [bar]	Max. rotation speed [min <sup>-1</sup> ]	Dimension [mm]				
	L	R			A	B			
4.0	0 510 225 306	0 510 225 006	250	4000	39.8	85.2			
5.5	0 510 325 306	0 510 325 006	250	4000	41.1	87.5			
8.0	0 510 425 307	0 510 425 009	250	4000	43.1	91.8			
11.0	0 510 525 311	0 510 525 009	250	3500	47.5	96.8			
14.0	0 510 525 319	0 510 525 018	250	3000	47.5	101.8			
16.0	0 510 625 315	0 510 625 022	250	3000	47.5	105.2			
19.0	0 510 625 314	0 510 625 013	210	3000	47.5	110.2			
22.5	0 510 725 330	0 510 725 030	180	2500	55.0	115.6			
25.0									
28.0									

\* Contact factory for availability of units with no ordering number listed.



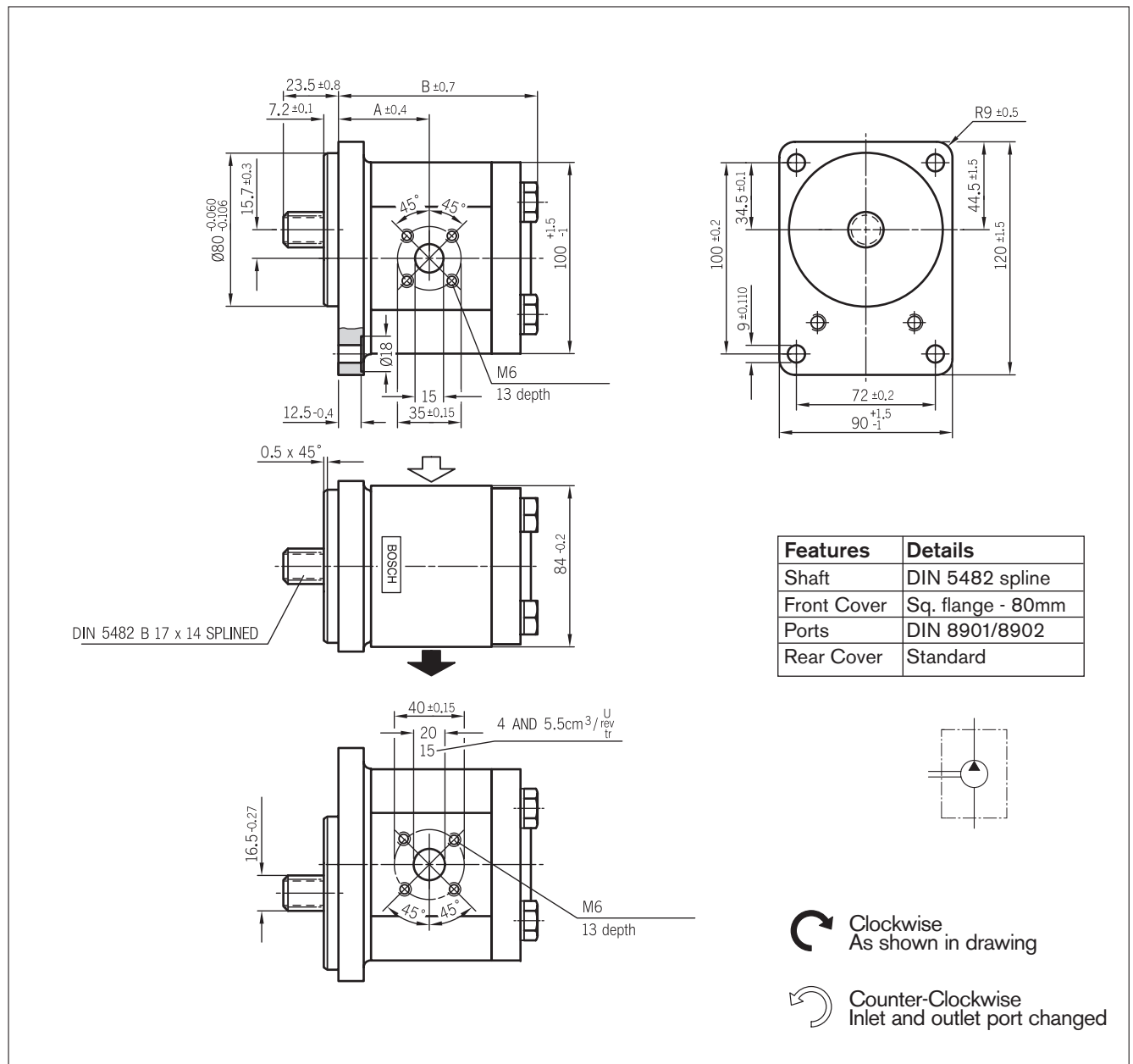

Ordering code

AZPF - X X - □ □ □ □ F B 20 MB

Displacement [cm <sup>3</sup> /rev]	Ordering-Number *		Max. operating pressure [bar]	Max. rotation speed [min <sup>-1</sup> ]	Dimension [mm]				
	L	R			A	B			
4.0	0 510 225 307	0 510 225 007	250	4000	39.8	85.2			
5.5	0 510 325 307	0 510 325 007	250	4000	41.0	87.5			
8.0	0 510 425 308	0 510 425 010	250	4000	43.1	91.8			
11.0	0 510 525 312	0 510 525 010	250	3500	47.5	96.6			
14.0	0 510 525 328	0 510 525 030	250	3000	47.5	101.8			
16.0	0 510 625 317	0 510 625 015	250	3000	47.5	105.2			
19.0	0 510 625 316	0 510 625 014	210	3000	47.5	110.2			
22.5		0 510 725 062	180	2500	55.0	115.6			
25.0									
28.0									

\* Contact factory for availability of units with no ordering number listed.

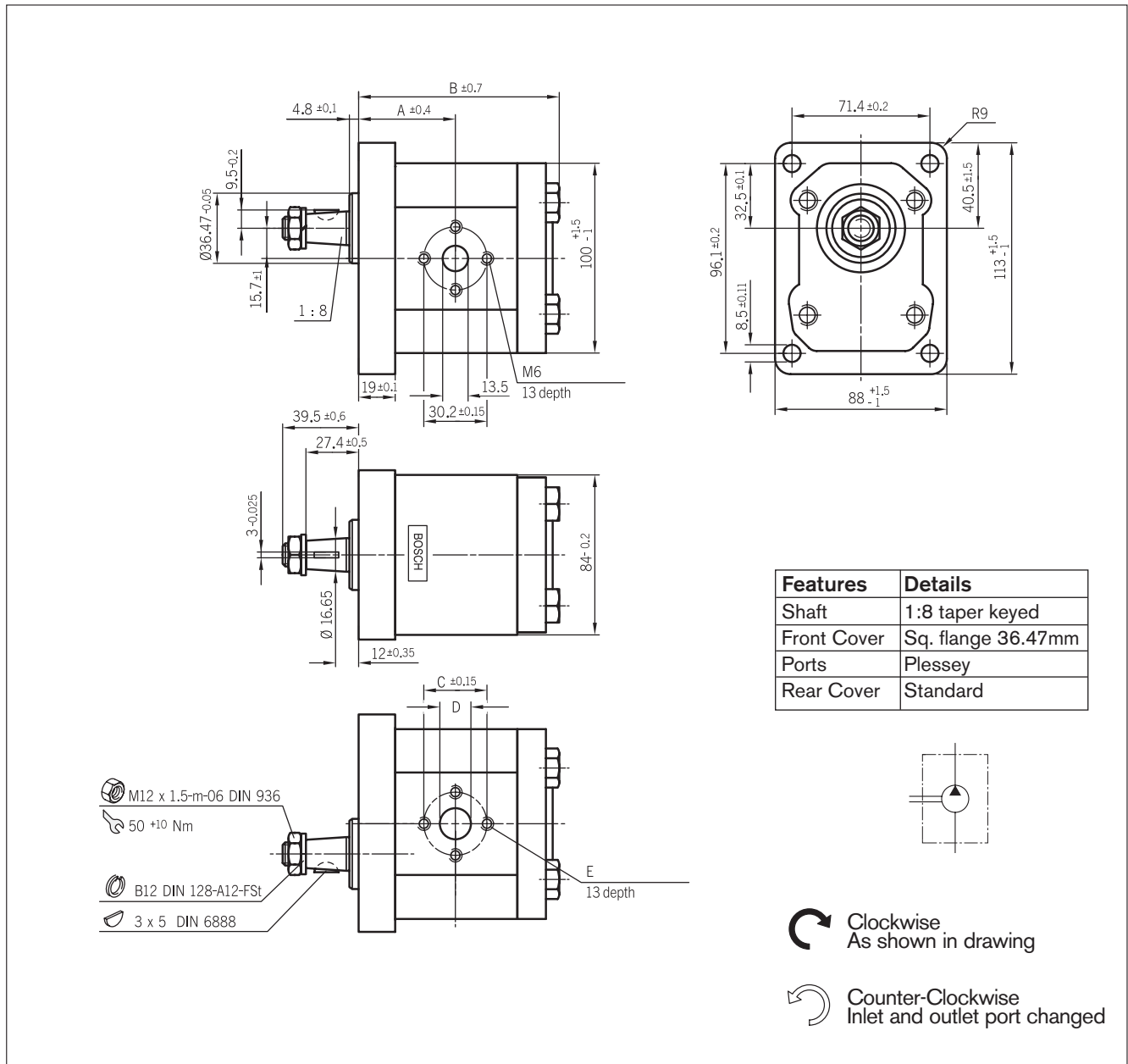

**Ordering code**  
**AZPF - X X - □□□□ H O 30 MB**

Displacement [cm <sup>3</sup> /rev]	Ordering-Number *		Max. operating pressure [bar]	Max. rotation speed [min <sup>-1</sup> ]	Dimension [mm]				
	L	R			A	B	C	D	E
4.0	0 510 225 308	0 510 225 008	280	4000	41.4	86.5	30.2	13.5	M6
5.5	0 510 325 308	0 510 325 008	280	4000	42.5	89.0	30.2	13.5	M6
8.0	0 510 425 309	0 510 425 011	280	4000	44.6	93.3	30.2	13.5	M6
11.0	0 510 525 313	0 510 525 011	280	3500	49.0	98.3	39.7	20.0	M8
14.0	0 510 525 314	0 510 525 012	280	3000	49.0	103.1	39.7	20.0	M8
16.0	0 510 625 318	0 510 625 016	280	3000	49.0	106.5	39.7	20.0	M8
19.0	0 510 625 319	0 510 625 017	210	3000	49.0	111.5	39.7	20.0	M8
22.5	0 510 725 331	0 510 725 031	180	2500	56.6	116.9	39.7	20.0	M8
25.0									
28.0									

\* Contact factory for availability of units with no ordering number listed.

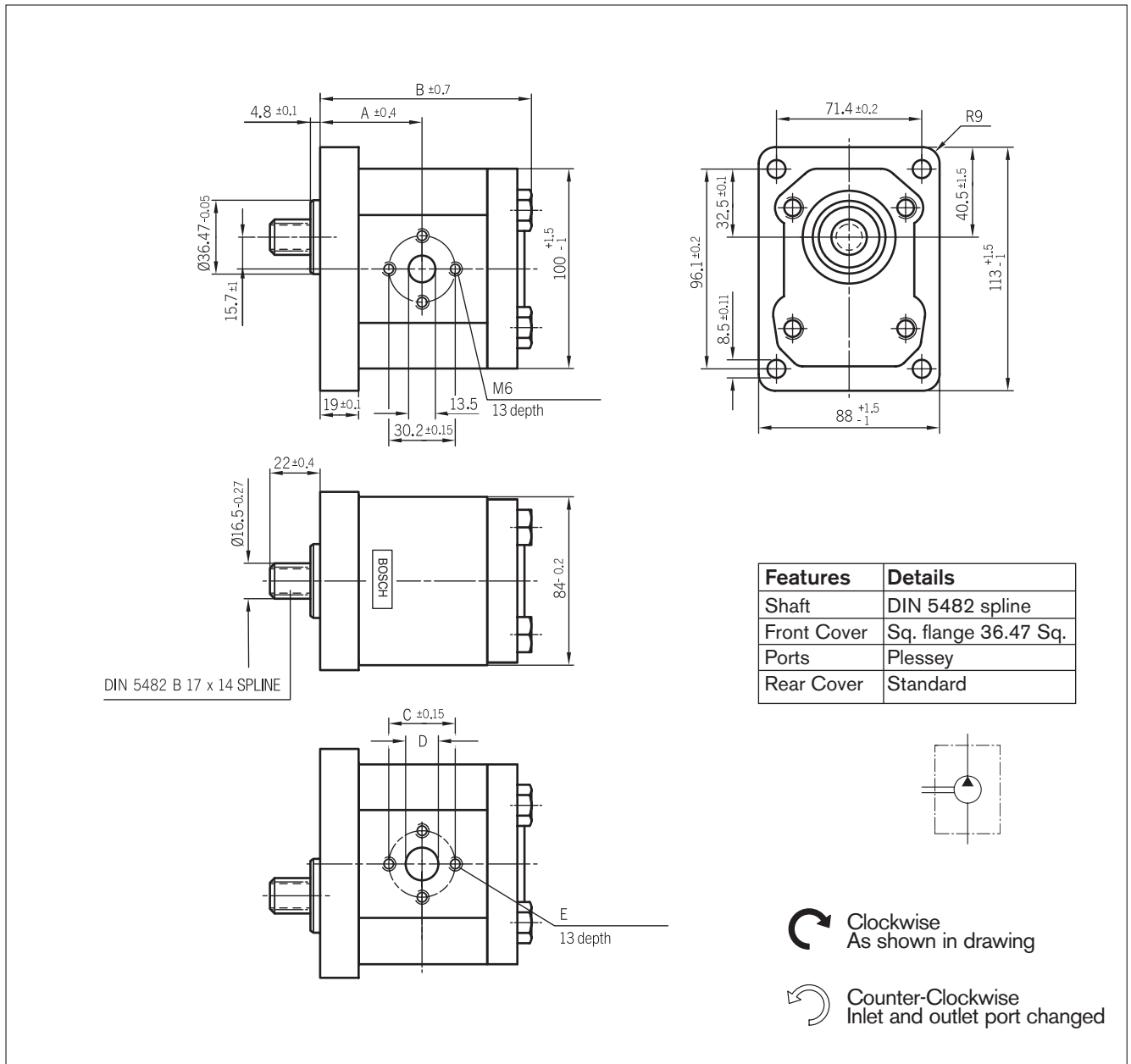

**Ordering code**

**AZPF - X X - □ □ □ □ F O 30 MB**

Displacement [cm³/rev]	Ordering-Number *		Max. operating pressure [bar]	Max. rotation speed [min⁻¹]	Dimension [mm]				
	L	R			A	B	C	D	E
8.0	0 510 425 315	0 510 425 021	250	4000	44.6	93.3	30.2	13.5	M6
11.0	0 510 525 323	0 510 525 024	250	3500	48.5	98.1	39.7	20.0	M8

\* Contact factory for availability of units with no ordering number listed.

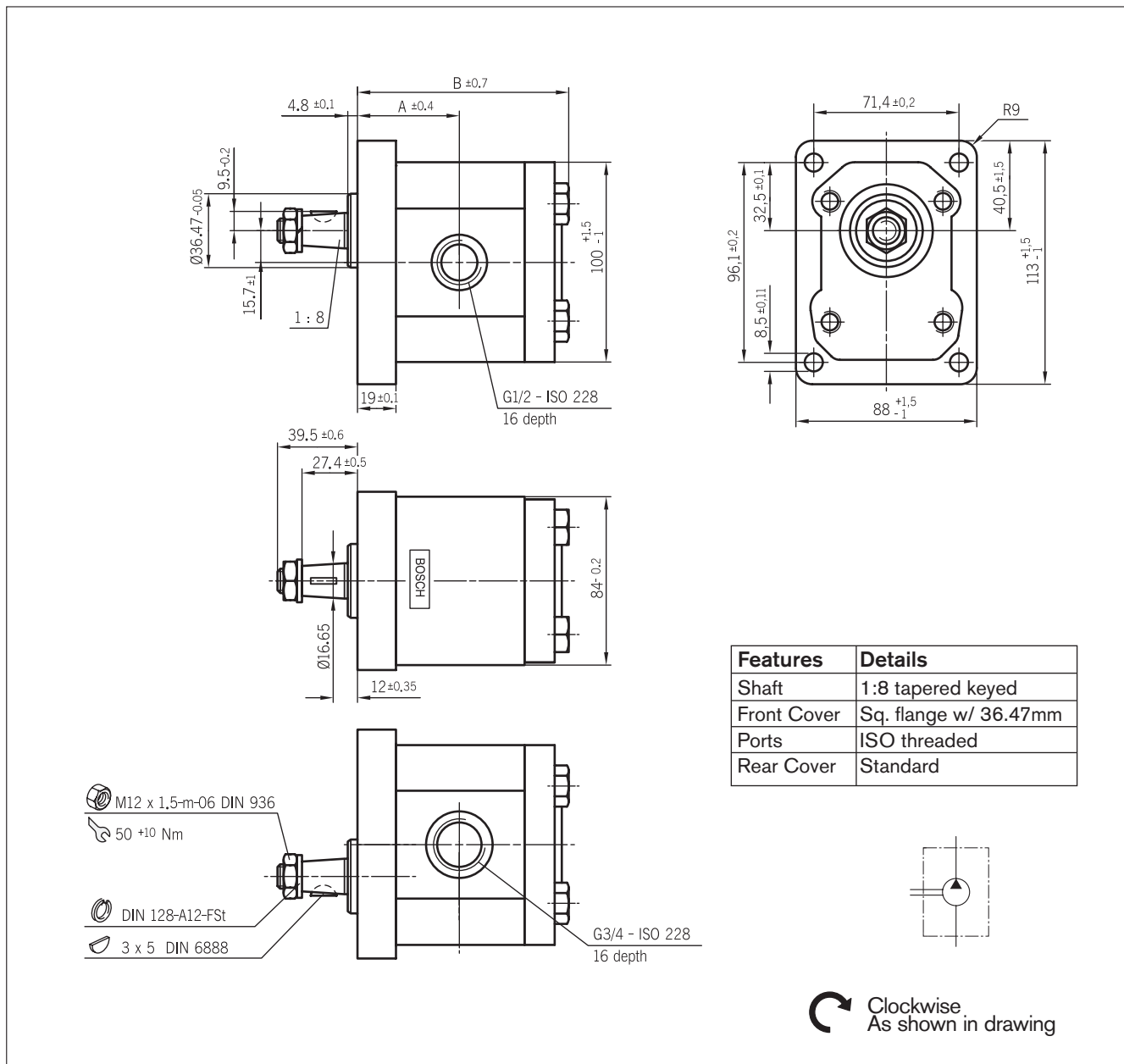

**Ordering code**  
**AZPF - X X - □ □ □ □ H O 01 MB**

Displacement [cm <sup>3</sup> /rev]	Ordering-Number *		Max. operating pressure [bar]	Max. rotation speed [min <sup>-1</sup> ]	Dimension [mm]				
	L	R			A	B			
4.0		<b>0 510 225 015</b>	250	4000	41.4	86.5			
5.5		<b>0 510 325 018</b>	250	4000	42.6	89.0			
8.0		<b>0 510 425 027</b>	250	4000	44.7	93.1			
11.0		<b>0 510 525 039</b>	250	3500	48.5	98.1			
14.0		<b>0 510 525 040</b>	250	3000	49.0	103.1			
16.0		<b>0 510 625 047</b>	250	3000	49.0	106.5			
19.0		<b>0 510 625 052</b>	210	3000	49.0	111.5			
22.5		<b>0 510 725 084</b>	180	2500	56.6	116.4			
25.0									
28.0									

\* Contact factory for availability of units with no ordering number listed.

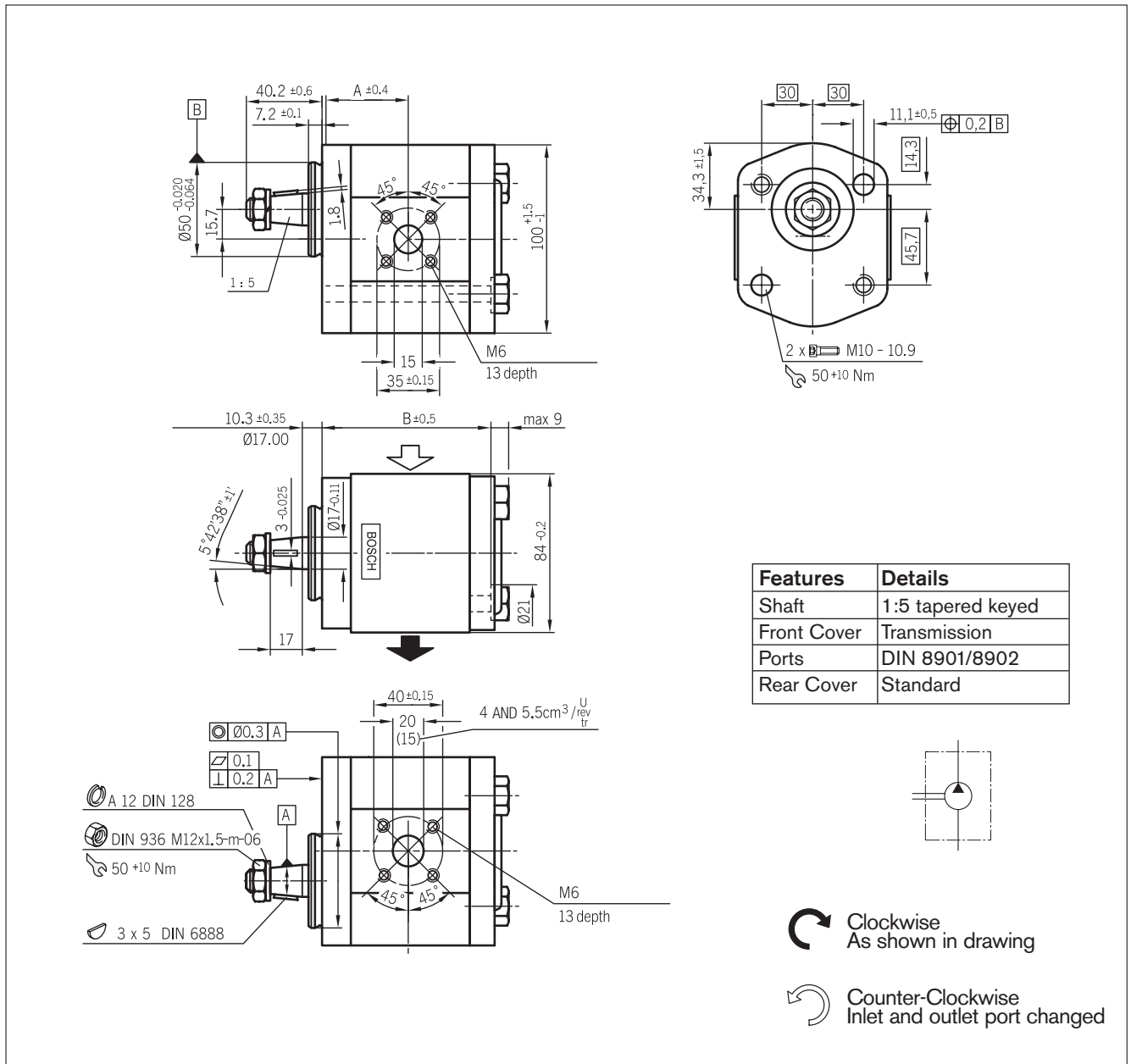

**Ordering code**

**AZPF - X X - □ □ □ □ C N 20 MB**

Displacement [cm <sup>3</sup> /rev]	Ordering-Number *		Max. operating pressure [bar]	Max. rotation speed [min <sup>-1</sup> ]	Dimension [mm]				
	L	R			A	B			
4.0	<b>0 510 215 306</b>	<b>0 510 215 006</b>	250	4000	37.4	73.7			
5.5	<b>0 510 315 304</b>	<b>0 510 315 004</b>	250	4000	38.6	76.2			
8.0	<b>0 510 415 313</b>	<b>0 510 415 005</b>	250	4000	40.7	80.3			
11.0	<b>0 510 515 310</b>	<b>0 510 515 004</b>	250	3500	44.5	85.3			
14.0		<b>0 510 515 015</b>	250	3000	45.0	90.3			
16.0	<b>0 510 615 314</b>	<b>0 510 615 006</b>	250	3000	45.0	93.7			
19.0	<b>0 510 615 341</b>		210	3000	45.0	98.7			
22.5		<b>0 510 715 016</b>	180	2500	58.6	116.1			
25.0									
28.0									

\* Contact factory for availability of units with no ordering number listed.

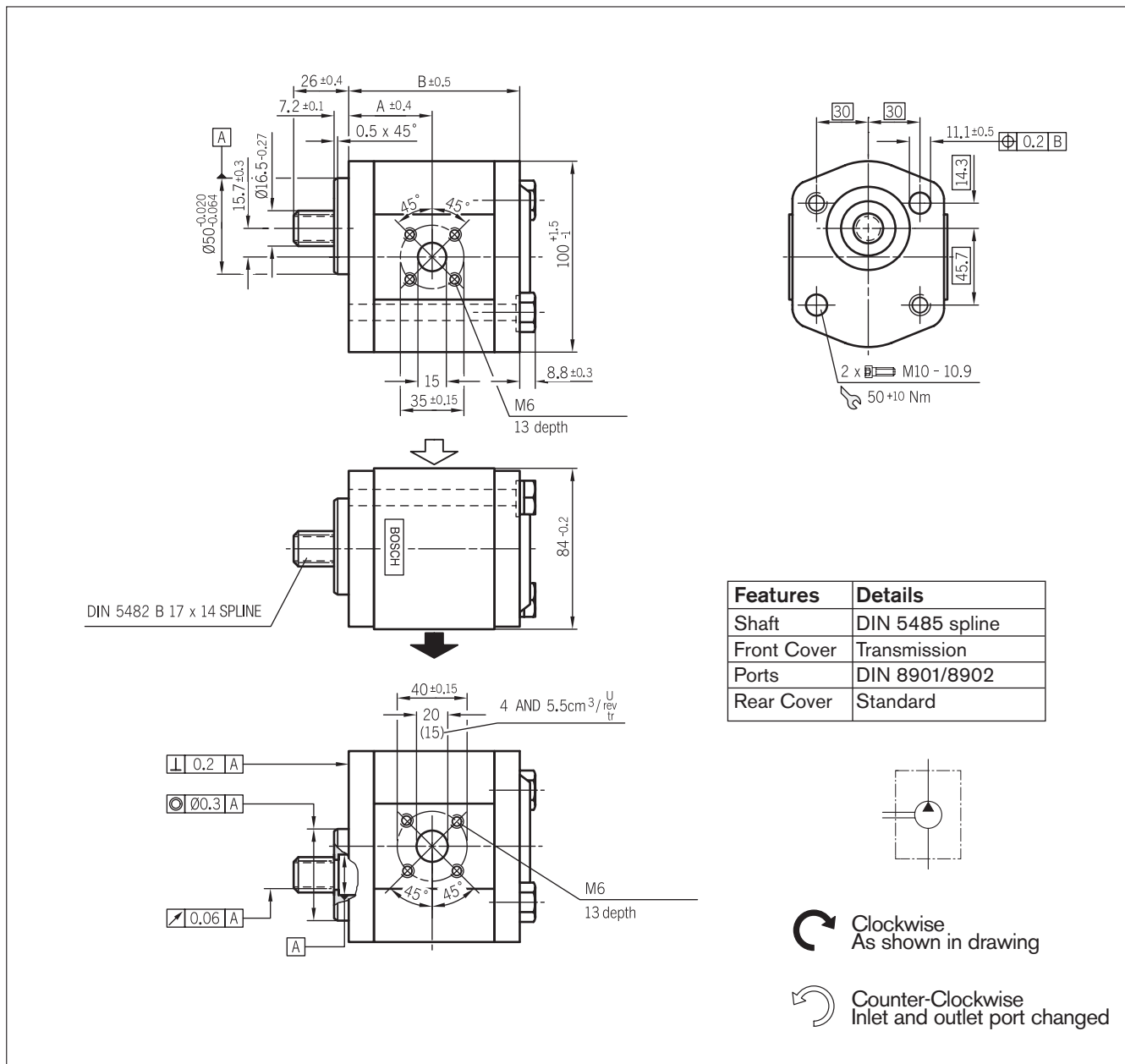

**Ordering code**  
**AZPF - X X - □ □ □ □ F N 20 MB**

Displacement [cm <sup>3</sup> /rev]	Ordering-Number *		Max. operating pressure [bar]	Max. rotation speed [min <sup>-1</sup> ]	Dimension [mm]				
	L	R			A	B			
5.5		<b>0 510 315 007</b>	250	4000	38.6	76.2			
11.0		<b>0 510 515 011</b>	250	3500	45.0	85.3			
19.0		<b>0 510 615 009</b>	210	3000	45.0	98.7			

\* Contact factory for availability of units with no ordering number listed.

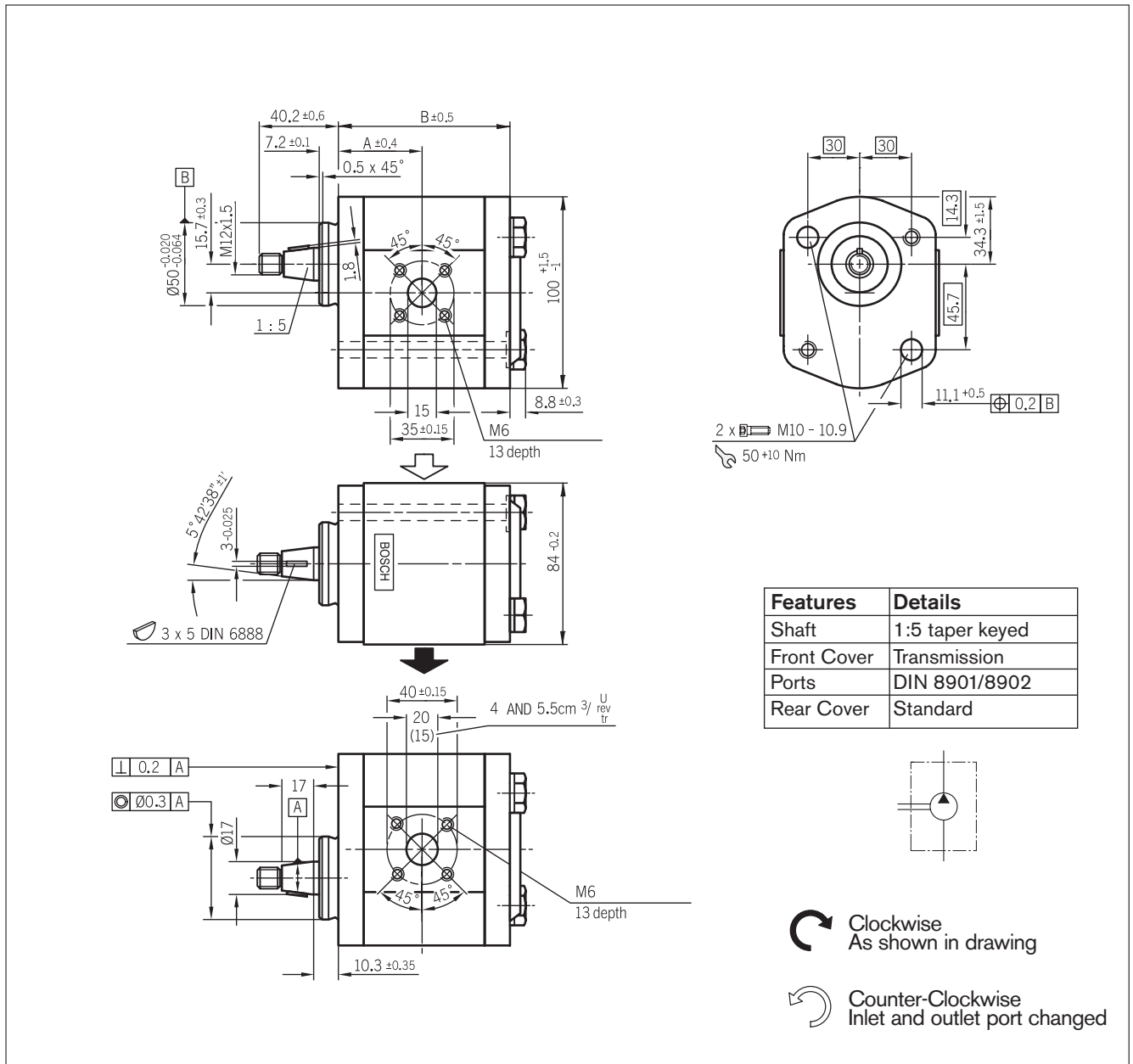

**Ordering code**

**AZPF - X X - □ □ □ □ C P 20 MB - S0007**

Displacement [cm <sup>3</sup> /rev]	Ordering-Number *		Max. operating pressure [bar]	Max. rotation speed [min <sup>-1</sup> ]	Dimension [mm]					
	L	R			A	B				
4.0	0 510 215 309	0 510 215 009	250	4000	37.3	73.7				
5.5	0 510 315 307	0 510 315 006	250	4000	38.6	76.2				
8.0	0 510 415 316		250	4000	40.6	80.3				
11.0	0 510 515 309	0 510 515 007	250	3500	45.0	85.3				
14.0	0 510 515 316	0 510 515 018	250	3000	45.0	90.3				
16.0	0 510 615 317	0 510 615 010	250	3000	45.0	93.7				
19.0	0 510 615 318	0 510 615 005	210	3000	45.0	98.7				
22.5	0 510 715 306		180	2500	52.5	104.1				
25.0										
28.0										

\* Contact factory for availability of units with no ordering number listed.

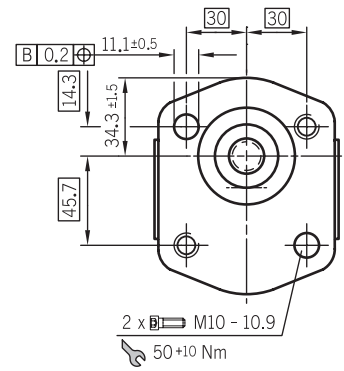
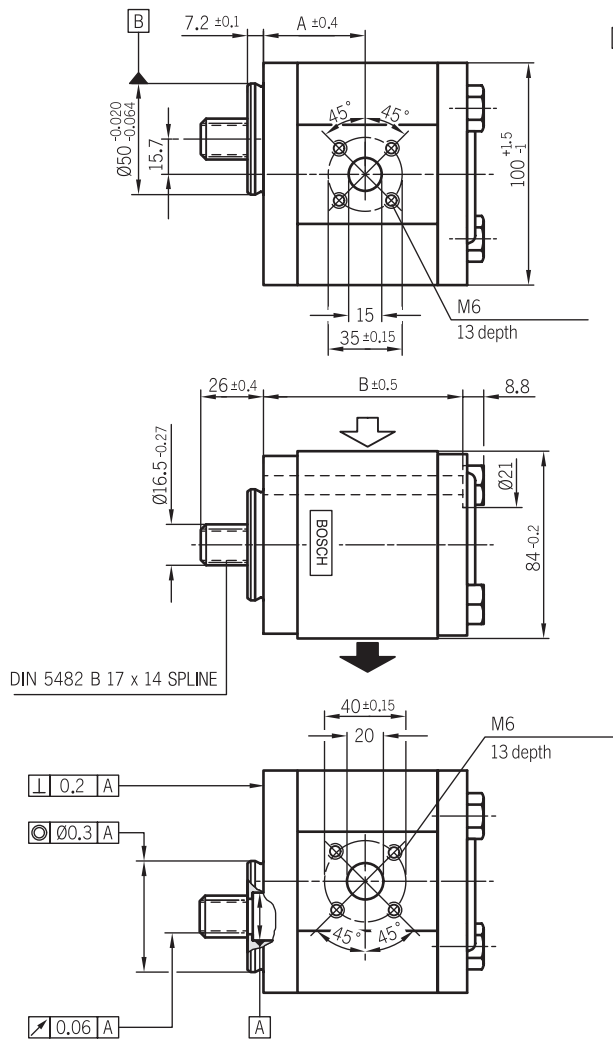

Features	Details
Shaft	DIN 5482 spline
Front Cover	Transmission
Ports	DIN 8901/8902
Rear Cover	Standard

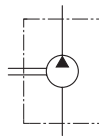



 Clockwise  
As shown in drawing

 Counter-Clockwise  
Inlet and outlet port changed

**Ordering code**

**AZPF - X X - □ □ □ □ F P 20 PB**

Displacement [cm <sup>3</sup> /rev]	Ordering-Number *		Max. operating pressure [bar]	Max. rotation speed [min <sup>-1</sup> ]	Dimension [mm]				
	 L	 R			A	B			
8.0	<b>0 510 415 328</b>		250	4000	40.7	80.3			
11.0	<b>0 510 515 337</b>	<b>0 510 515 012</b>	250	3500	44.5	85.3			
14.0	<b>0 510 515 338</b>	<b>0 510 515 013</b>	250	3000	45.0	90.3			
16.0		<b>0 510 615 023</b>	250	3000	45.0	93.7			
22.5	<b>0 510 715 320</b>	<b>0 510 715 008</b>	180	2500	58.6	116.1			

\* Contact factory for availability of units with no ordering number listed.







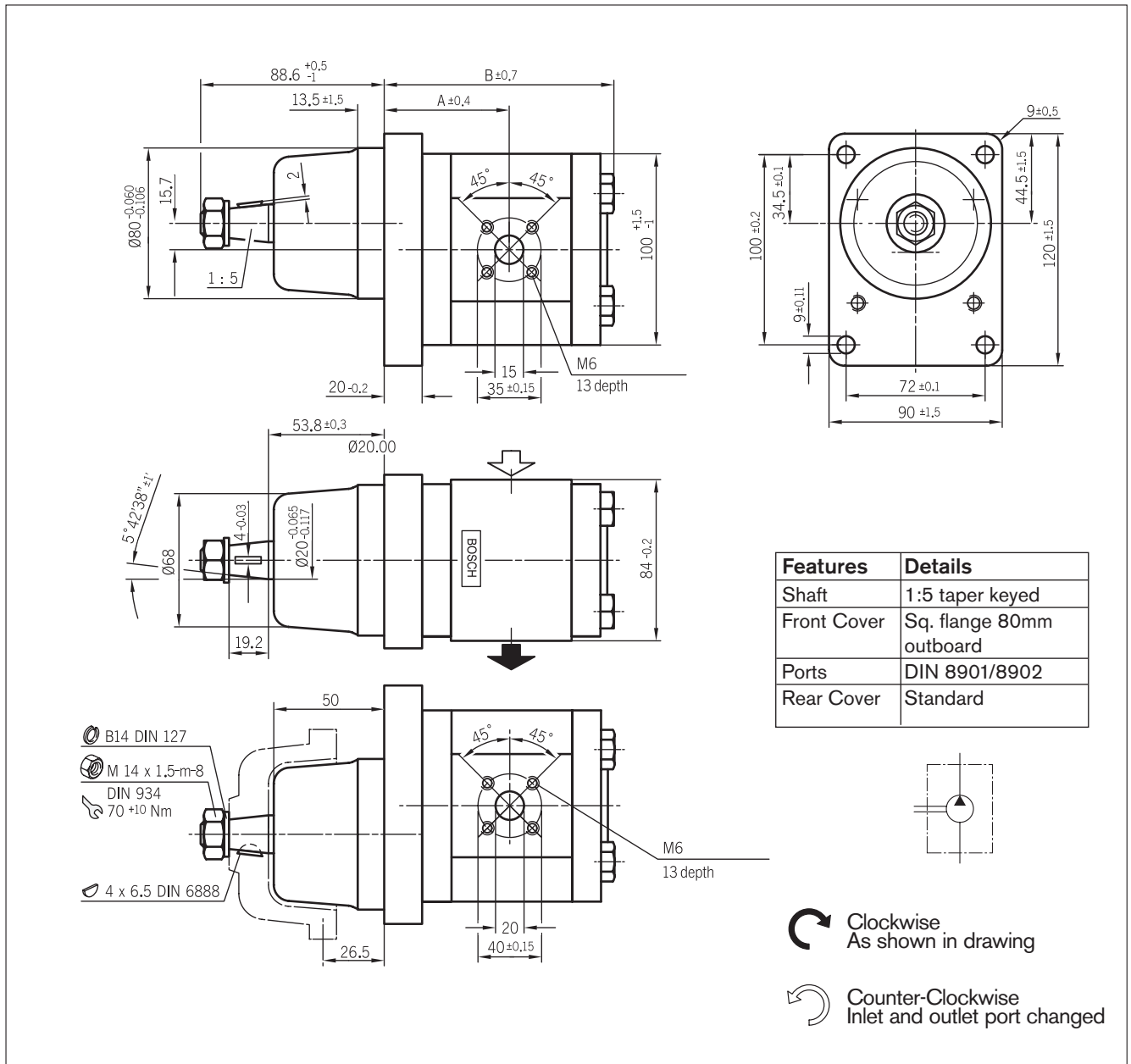















**Ordering code**  
**AZPF - X X - □□□□ S G 20 MB**

Displacement [cm <sup>3</sup> /rev]	Ordering-Number *		Max. operating pressure [bar]	Max. rotation speed [min <sup>-1</sup> ]	Dimension [mm]					
	L	R			A	B				
11.0		<b>0 510 545 003</b>	250	3500	64.5	113.8				
14.0	<b>0 510 545 302</b>	<b>0 510 545 002</b>	250	3000	65.0	119.1				
16.0		<b>0 510 645 005</b>	250	3000	65.0	122.5				
19.0		<b>0 510 645 003</b>	210	3000	65.0	127.5				

\* Contact factory for availability of units with no ordering number listed.

# Ordering Code (N Series Pump)

A Z		P		N - 1 □ - 0 3 2		R		D		C		1 2		M		B - S □ □ □ □ *	
<b>Function</b>		P = Pump														<b>End cover</b>	
<b>Size (N)</b>																Standard = B Rear Ports = A	
1.28 in <sup>3</sup> (20.4 cm <sup>3</sup> ) = 020																<b>Seals</b>	
1.44 in <sup>3</sup> (23.1 cm <sup>3</sup> ) = 022																NBR = M	
1.61 in <sup>3</sup> (25.8 cm <sup>3</sup> ) = 025																FPM = P	
1.78 in <sup>3</sup> (28.4 cm <sup>3</sup> ) = 028																NBR, shaft seal in FPM = K	
2.02 in <sup>3</sup> (32.4 cm <sup>3</sup> ) = 032																	
2.28 in <sup>3</sup> (36.4 cm <sup>3</sup> ) = 036																	
<b>Direction of rotation</b>																	
Right = R																	
Left = L																	
Drive shafts				Front flange				Line connections									
<b>C</b> Conical 1:5 (Tapered key) 				<b>B</b> Square flange Pilot Ø 100 mm 				<b>20</b> Rectangular flange 									
<b>N</b> Dog (Tang) 				<b>C</b> SAE B 2-bolt 				<b>12</b> Thread (UN-2B) SAE O-ring BOSS 									
<b>D</b> Spline shaft SAE B 13T 				<b>M</b> Transmission flange Pilot Ø 52 mm with O-ring 				<b>07</b> Split flange SAE Code 61 Metric bolts 									
<b>P</b> Spline shaft SAE 11T 				<b>R</b> SAE A 2-bolt 				<b>40</b> Split flange SAE Code 61 UNC bolts 									
<b>Q</b> SAE 3/4" Keyed Short 				<b>R</b>													
<b>Q</b> SAE 3/4" Keyed Long - use S0022 Suffix 				<b>C</b>													
<b>X</b> Special (SO Code Defines Special Shaft)				<b>R</b>													
				<b>C</b>													

\* Common Suffix Codes:  
 S0075 – Tapered shaft  
 Contact Factory for additional codes.

Size **N**  
**20 ... 36 cm<sup>3</sup>/rev**

## N Series Pump Product Index

(Reference page 43 for ordering code designators)

AZPF-XX-XXXX - - - MB

Page Number	Ordering code	Shaft Type	Mounting Flange	Ports	Port Orientation
49	AZPN-12-XXXXPC12MB	P	C	12	side
50	AZPN-12-XXXXPC12MA	P	C	12	rear
51	AZPN-12-XXXXPR12MB	P	R	12	side
52	AZPN-12-XXXXPR12MA	P	R	12	rear
53	AZPN-12-XXXXQC12MB	Q	C	12	side
54	AZPN-12-XXXXQC12MA	Q	C	12	rear
55	AZPN-12-XXXXQR12MB	Q	R	12	side
56	AZPN-12-XXXXQR12MA	Q	R	12	rear
57	AZPN-12-XXXXRR12MB	R	R	12	side
58	AZPN-12-XXXXRR12MA	R	R	12	rear
59	AZPN-12-XXXXDC12MB	D	C	12	side
60	AZPN-12-XXXXDC12MA	D	C	12	rear
61	AZPN-12-XXXXDR12MB	D	R	12	side
62	AZPN-12-XXXXDR12MA	D	R	12	rear
63	AZPN-12-XXXXXR12MB-S0075	X-S0075	R	12	side
64	AZPN-12-XXXXXR12MA-S0075	X-S0075	R	12	rear
65	AZPN-12-XXXXDC20MB	D	C	20	side
66	AZPN-12-XXXXCB20MB	C	B	20	side
67	AZPN-12-XXXXNM20MB	N	M	20	side

**N Series Performance Ratings**

Size		020	022	025	028	032	036
Displacement	cm <sup>3</sup> /rev	20.4	23.1	25.8	28.4	32.4	36.4
Inlet pressure	bar	min. 0.7 max. 3 (absolute)					
max. continuous pressure p <sub>1</sub>	bar	230	230	230	210	180	160
	psi	3335	3335	3335	3045	2610	2610
max. intermittent pressure p <sub>2</sub>	bar	250	250	250	230	200	180
	psi	3625	3625	3625	3335	2900	2610
max. peak pressure p <sub>3</sub>	bar	270	270	270	250	220	200
	psi	3915	3915	3915	3625	3190	2900
min. rotational speed (RPM) ≤ 100	RPM	500	500	500	500	500	500
max. rotational speed at (RPM) p <sub>1</sub>		2500	2500	2500	2300	2300	2100
p <sub>2</sub>		3000	3000	3000	2800	2800	2600

**N Series Pumps****SAE O-Ring BOSS - Standard Porting**

Displacement (cc)	Side Ports		Rear Port	
	Inlet	Outlet	Inlet	Outlet
20	-16	-10	-16	-12
22	-16	-10	-16	-12
25	-20	-12	-16	-12
28	-20	-12	-16	-12
32	-20	-12	-16	-12
36	-20	-12	-16	-12

**SAE Porting - Specifications and Dimensions  
per SAE J1926/1**

Dash Size	Thread Size (in)
-2	5/16-24 UNF-2B
-3	3/8-24 UNF-2B
-4	7/16-20 UNF-2B
-5	1/2-20 UNF-2B
-6	9/16-18 UNF-2B
-8	3/4-16 UNF-2B
-10	7/8-14 UNF-2B
-12	1-1/16-12 UN-2B
-14	1-3/16-12 UN-2B
-16	1-5/16-12 UN-2B
-20	1-5/8-12 UN-2B
-24	1-7/8-12 UN-2B
-32	2-1/2-12 UN-2B

Note: Ratings represent units incorporating SAE O-Ring BOSS threaded ports. Pressure ratings may differ for other types of ports.

**Diagrams**

Size **N**

$v = 35 \text{ mm}^2/\text{s}, T = 50 \text{ }^\circ\text{C}$

**Unit Conversions**

- Pressure: psi = bar x 14.7
- Torque: ft-lbs = (Nm) x .738
- Power: hp = (kW) x 1.341
- Volume: in<sup>3</sup> = (cc) x 16.39
- gpm = (LPM) x .2642

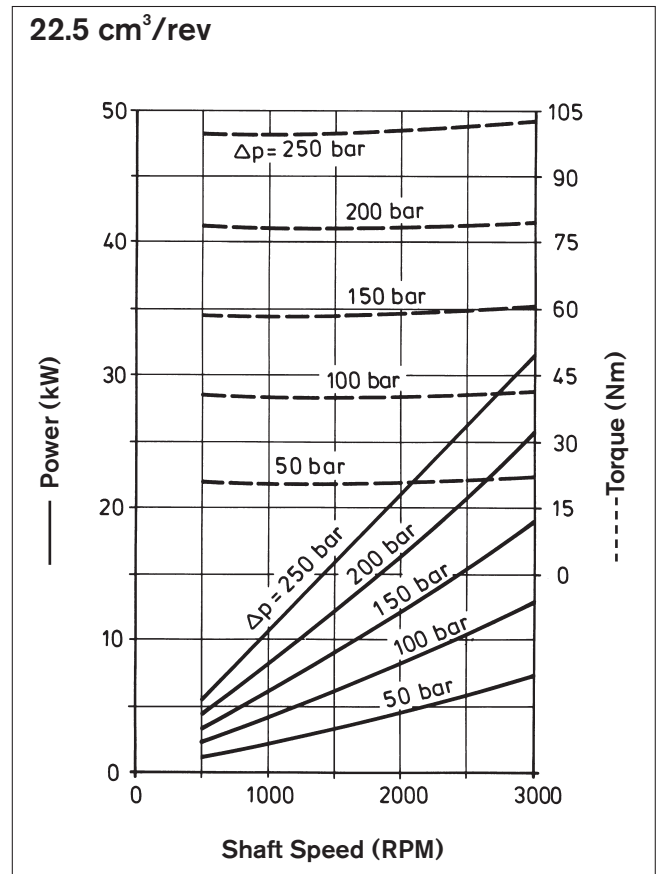
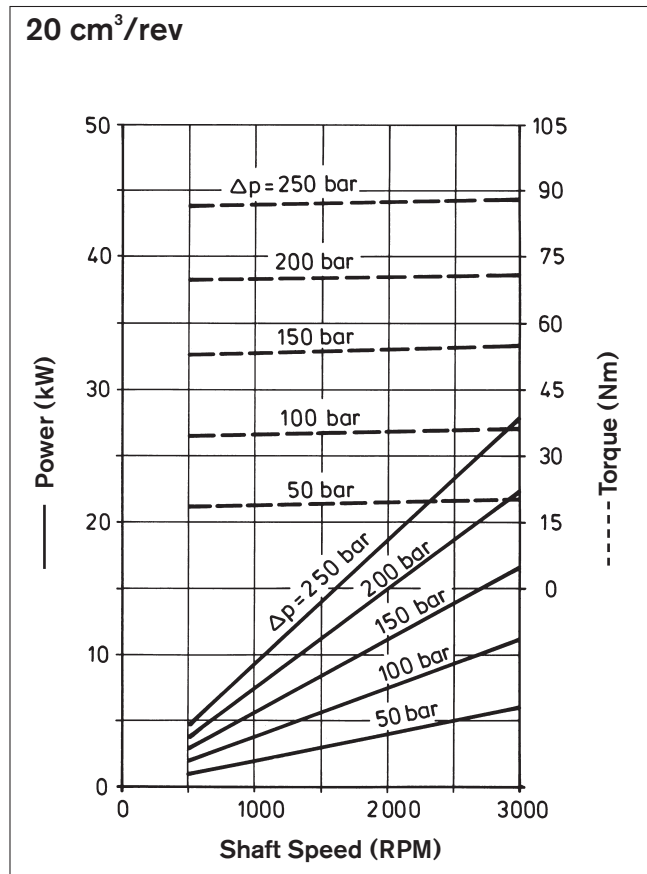
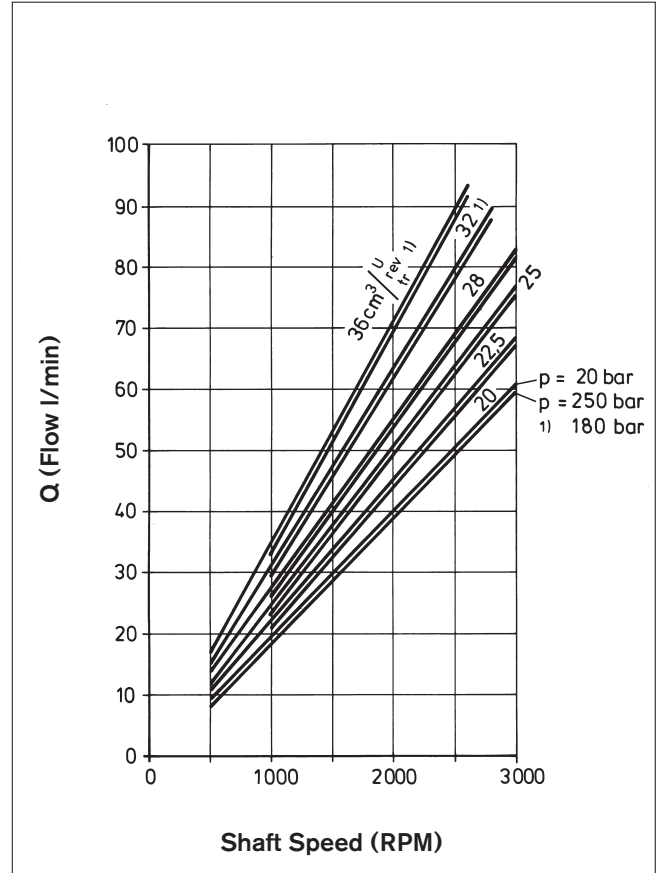

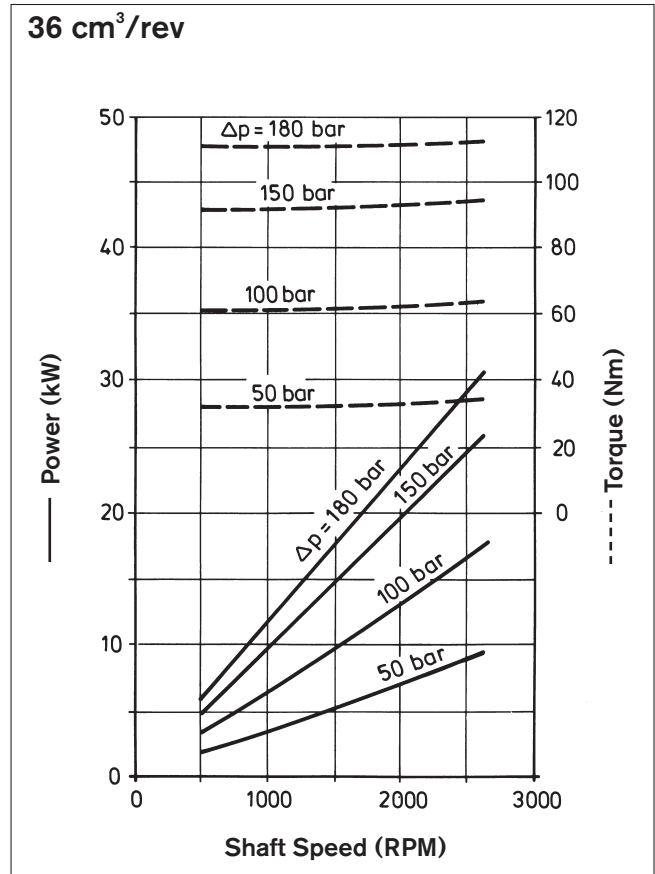
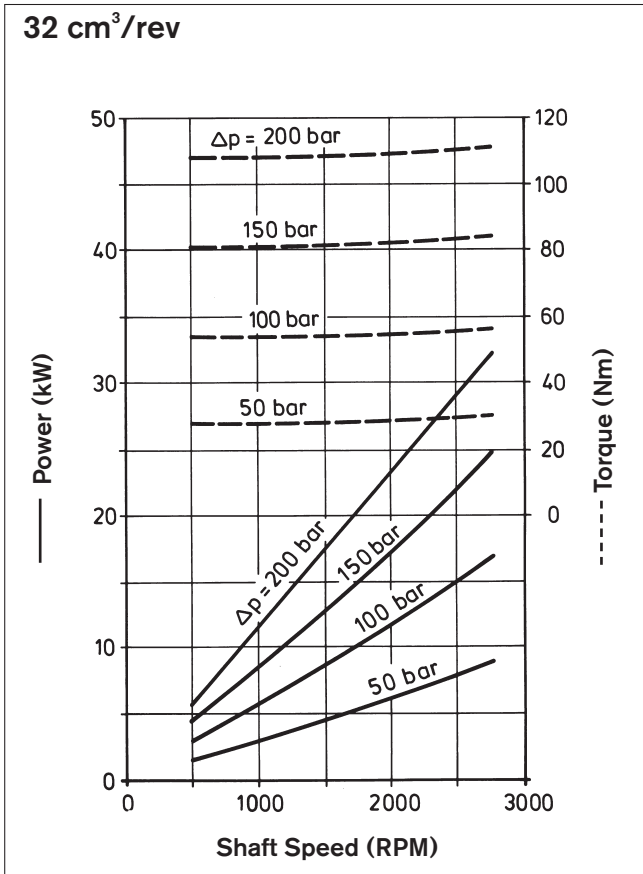
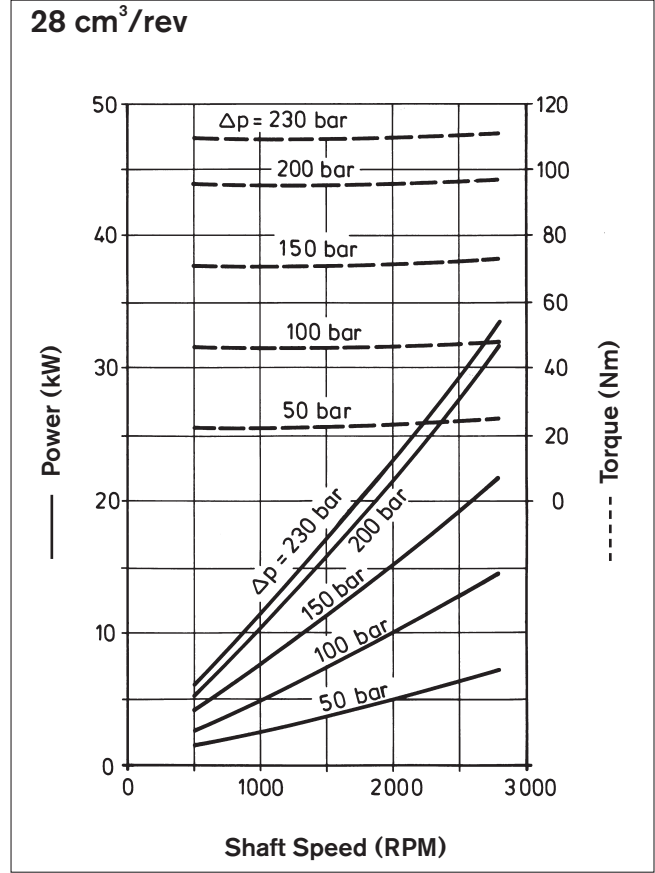
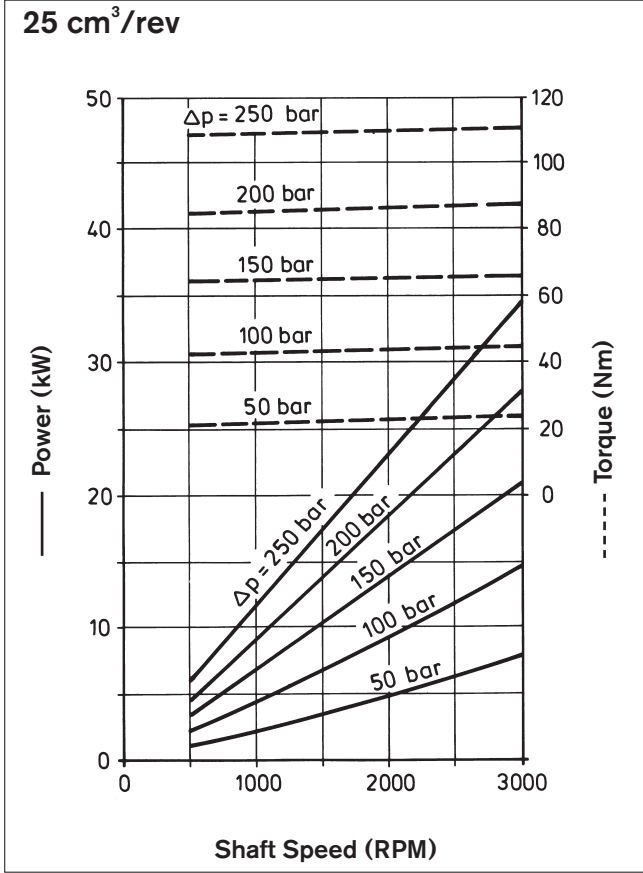



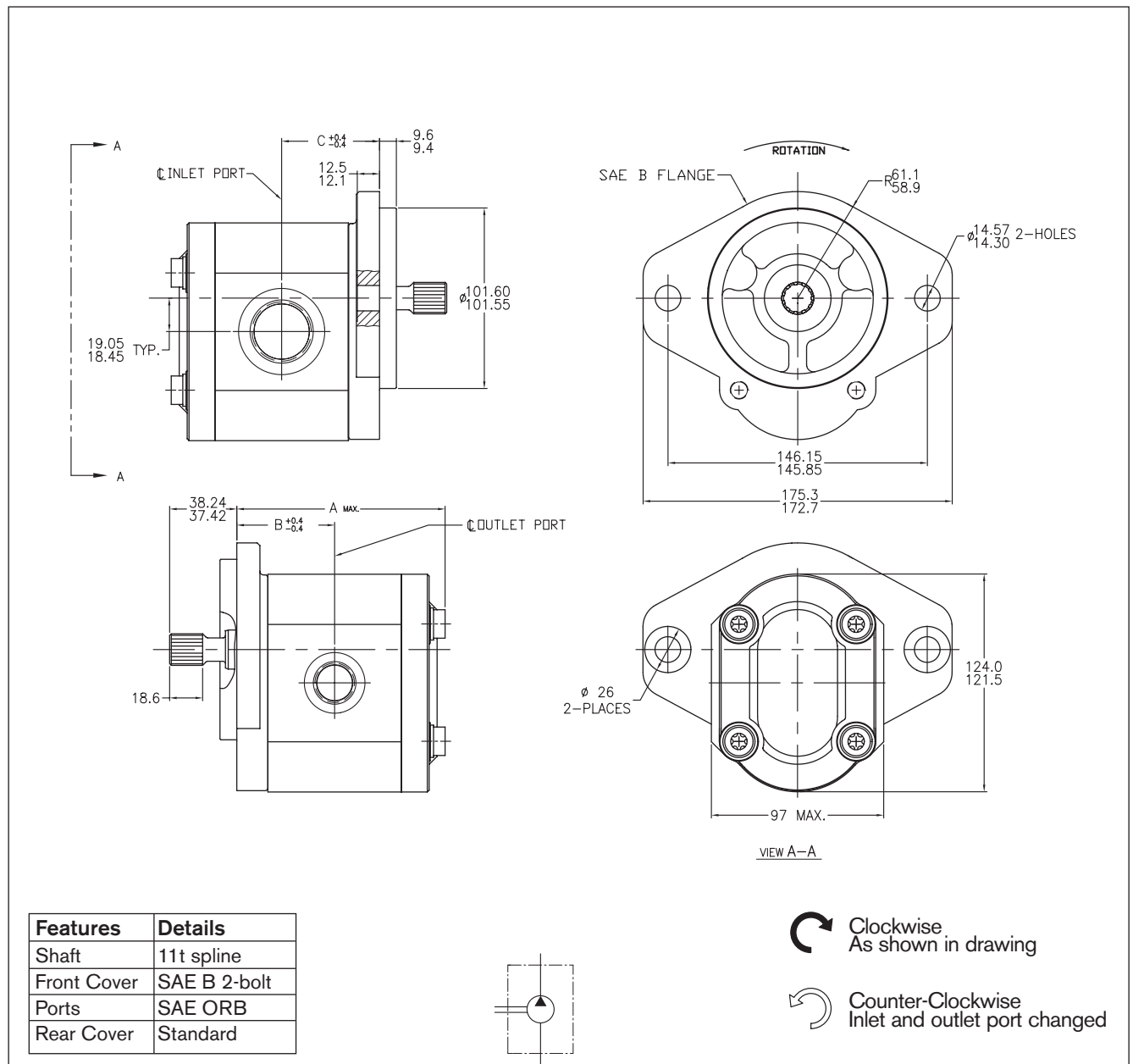

**Ordering code**

**AZPN - X X - □ □ □ □ P C 12 MB**

Displacement [cm <sup>3</sup> /rev]	Ordering-Number *		Max. operating pressure [bar]	Max. rotation speed [min <sup>-1</sup> ]	Dimension [mm]			Inlet Port ** (SAE O-Ring BOSS)	Outlet Port (SAE O-Ring BOSS)
	L	R			A	B	C		
20.0	<b>9 510 390 153</b>	<b>9 510 390 147</b>	230	3000	109.8	52.1	52.1	-16	-10
22.0	<b>9 510 390 154</b>	<b>9 510 390 148</b>	230	3000	114.7	53.6	53.1	-16	-10
25.0	<b>9 510 390 155</b>	<b>9 510 390 149</b>	230	3000	115.8	55.1	55.1	-20	-12
28.0	<b>9 510 390 156</b>	<b>9 510 390 150</b>	210	2800	118.8	56.6	56.1	-20	-12
32.0	<b>9 510 390 157</b>	<b>9 510 390 151</b>	180	2800	123.3	58.8	58.8	-20	-12
36.0	<b>9 510 390 158</b>	<b>9 510 390 152</b>	160	2600	129.7	61.1	61.1	-20	-12

\* Contact factory for availability of units with no ordering number listed.

\*\* Refer to page 46 for SAE O-Ring Boss Specifications and Dimensions.

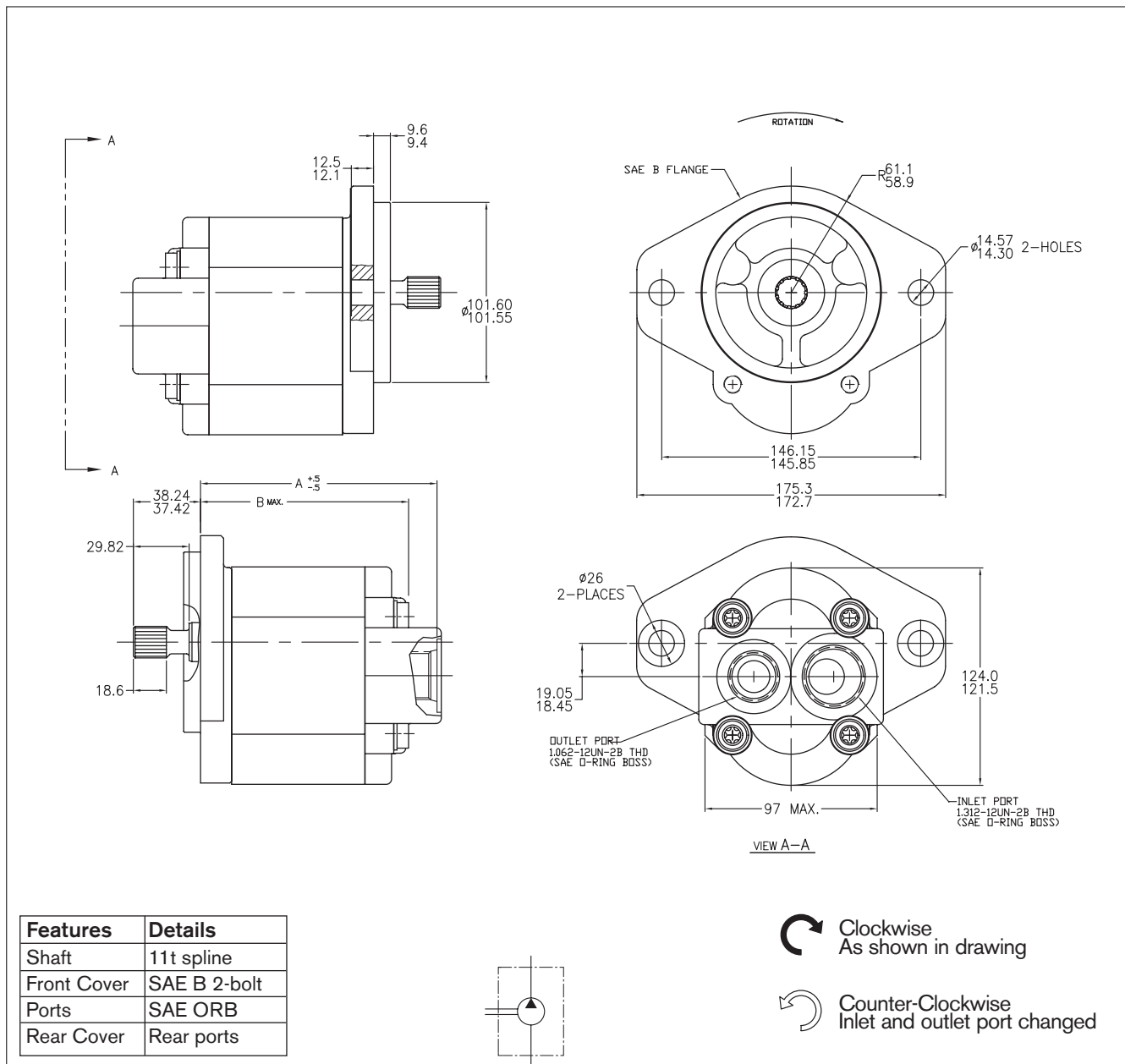

**Ordering code**

AZPN - X X - □ □ □ □ P C 12 MA

Displacement [cm <sup>3</sup> /rev]	Ordering-Number *		Max. operating pressure [bar]	Max. rotation speed [min <sup>-1</sup> ]	Dimension [mm]		Inlet Port ** (SAE O-Ring BOSS)	Outlet Port (SAE O-Ring BOSS)
	L	R			A	B		
20.0	9 510 390 104	9 510 390 098	230	3000	128.1	110.0	-16	-12
22.0	9 510 390 105	9 510 390 099	230	3000	131.1	114.9	-16	-12
25.0	9 510 390 106	9 510 390 100	230	3000	134.1	116.0	-16	-12
28.0	9 510 390 107	9 510 390 101	210	2800	137.1	119.0	-16	-12
32.0	9 510 390 108	9 510 390 102	180	2800	141.6	123.5	-16	-12
36.0	9 510 390 109	9 510 390 103	160	2600	146.1	124.4	-16	-12

\* Contact factory for availability of units with no ordering number listed.  
 \*\* Refer to page 46 for SAE O-Ring Boss Specifications and Dimensions.

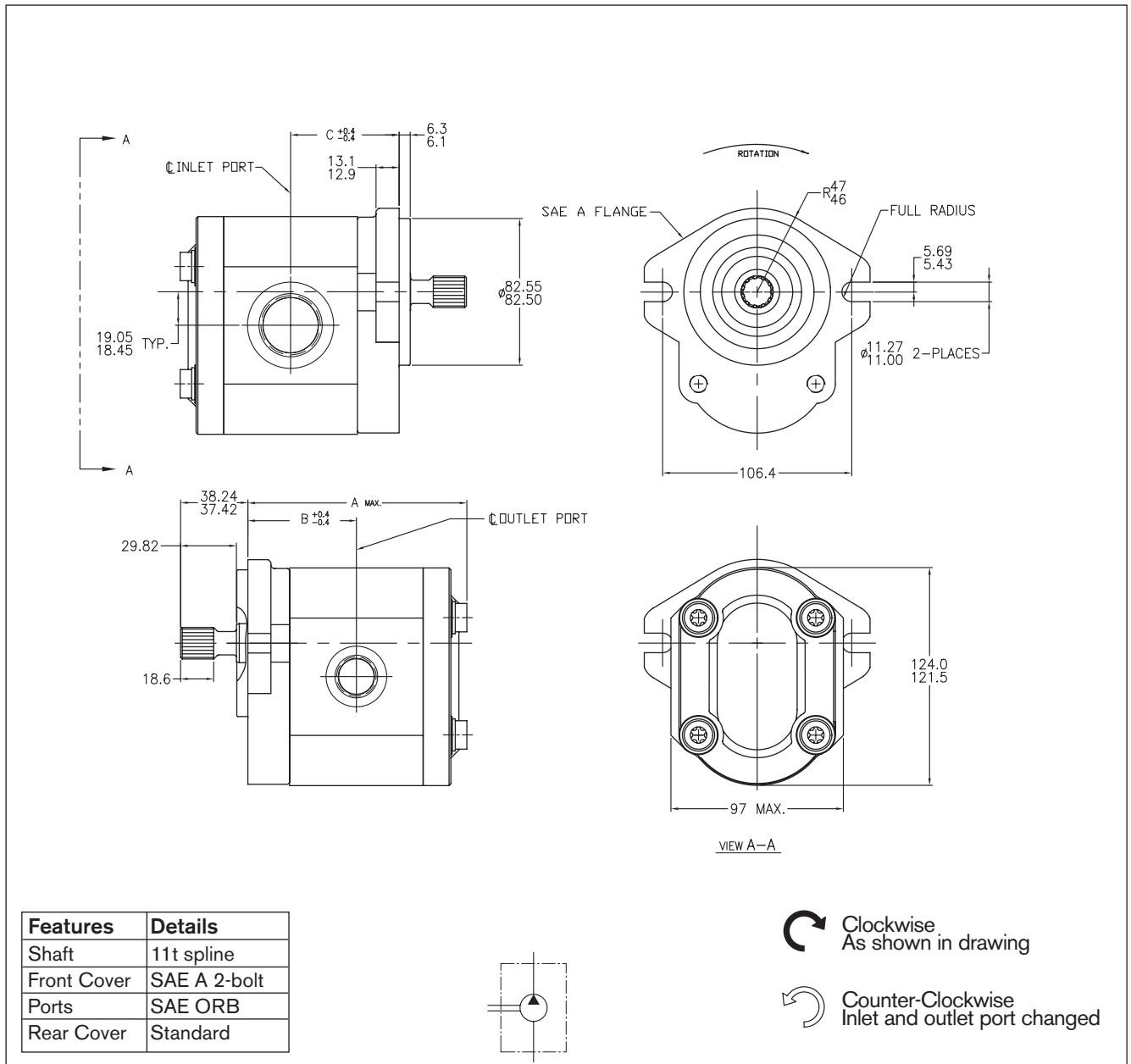

**Ordering code**

**AZPN - X X - □ □ □ □ P R 12 MB**

Displacement [cm <sup>3</sup> /rev]	Ordering-Number *		Max. operating pressure [bar]	Max. rotation speed [min <sup>-1</sup> ]	Dimension [mm]			Inlet Port ** (SAE O-Ring BOSS)	Outlet Port (SAE O-Ring BOSS)
	L	R			A	B	C		
20.0	<b>9 510 390 165</b>	<b>9 510 390 159</b>	230	3000	115.4	58.1	58.1	-16	-10
22.0	<b>9 510 390 166</b>	<b>9 510 390 160</b>	230	3000	118.4	59.6	59.6	-16	-10
25.0	<b>9 510 390 167</b>	<b>9 510 390 161</b>	230	3000	121.4	61.1	61.1	-20	-12
28.0	<b>9 510 390 168</b>	<b>9 510 390 162</b>	210	2800	124.4	62.6	62.6	-20	-12
32.0	<b>9 510 390 169</b>	<b>9 510 390 163</b>	180	2800	128.5	64.8	64.8	-20	-12
36.0	<b>9 510 390 170</b>	<b>9 510 390 164</b>	160	2600	133.0	67.1	67.1	-20	-12

\* Contact factory for availability of units with no ordering number listed.

\*\* Refer to page 46 for SAE O-Ring Boss Specifications and Dimensions.

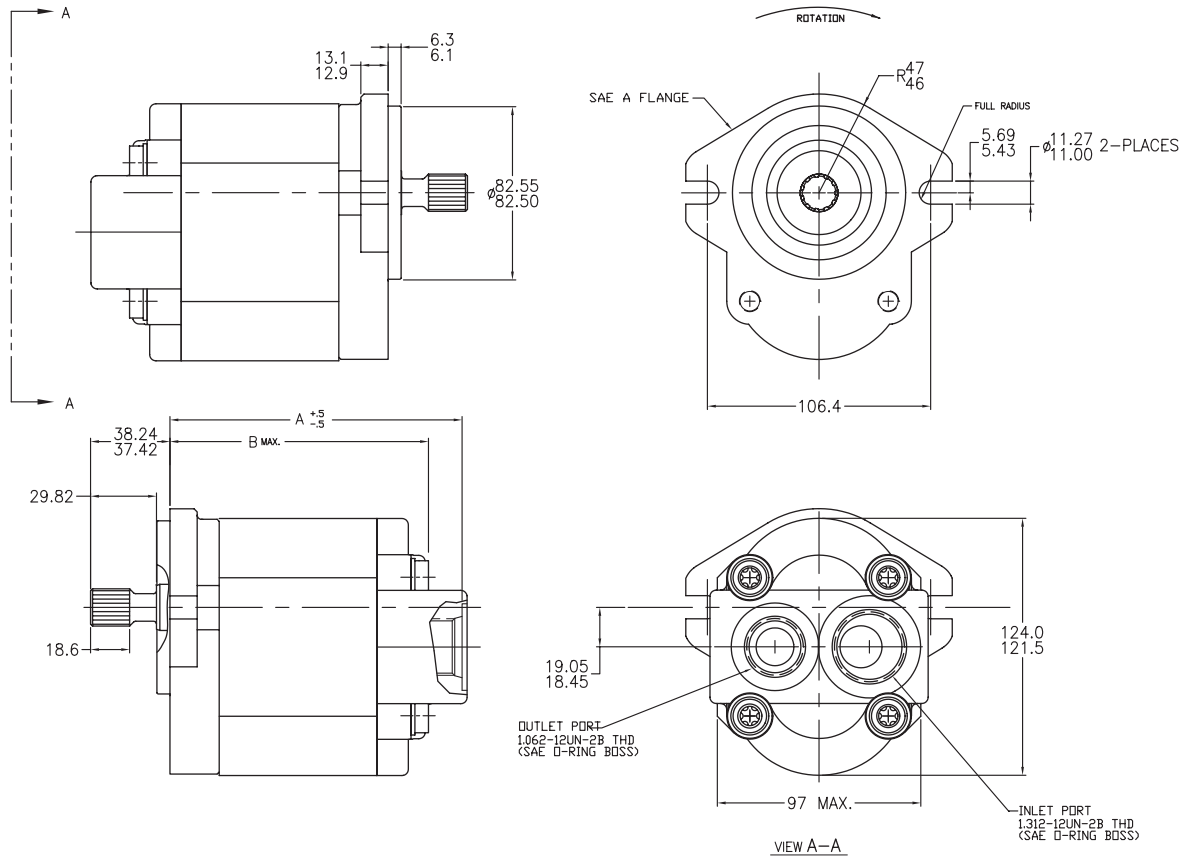

Features	Details
Shaft	11t spline
Front Cover	SAE A 2-bolt
Ports	SAE ORB
Rear Cover	Rear ports

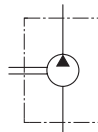

Clockwise  
As shown in drawing

Counter-Clockwise  
Inlet and outlet port changed

**Ordering code**  
AZPN - X X - □ □ □ □ P R 12 MA

Displacement [cm <sup>3</sup> /rev]	Ordering-Number *		Max. operating pressure [bar]	Max. rotation speed [min <sup>-1</sup> ]	Dimension [mm]		Inlet Port ** (SAE O-Ring BOSS)	Outlet Port (SAE O-Ring BOSS)
	L	R			A	B		
20.0	9 510 390 092	9 510 390 086	230	3000	134.1	116.0	-16	-12
22.0	9 510 390 093	9 510 390 087	230	3000	137.1	120.9	-16	-12
25.0	9 510 390 094	9 510 390 088	230	3000	140.1	122.0	-16	-12
28.0	9 510 390 095	9 510 390 089	210	2800	143.1	125.0	-16	-12
32.0	9 510 390 096	9 510 390 090	180	2800	147.6	129.5	-16	-12
36.0	9 510 390 097	9 510 390 091	160	2600	152.1	135.9	-16	-12

\* Contact factory for availability of units with no ordering number listed.  
\*\* Refer to page 46 for SAE O-Ring Boss Specifications and Dimensions.

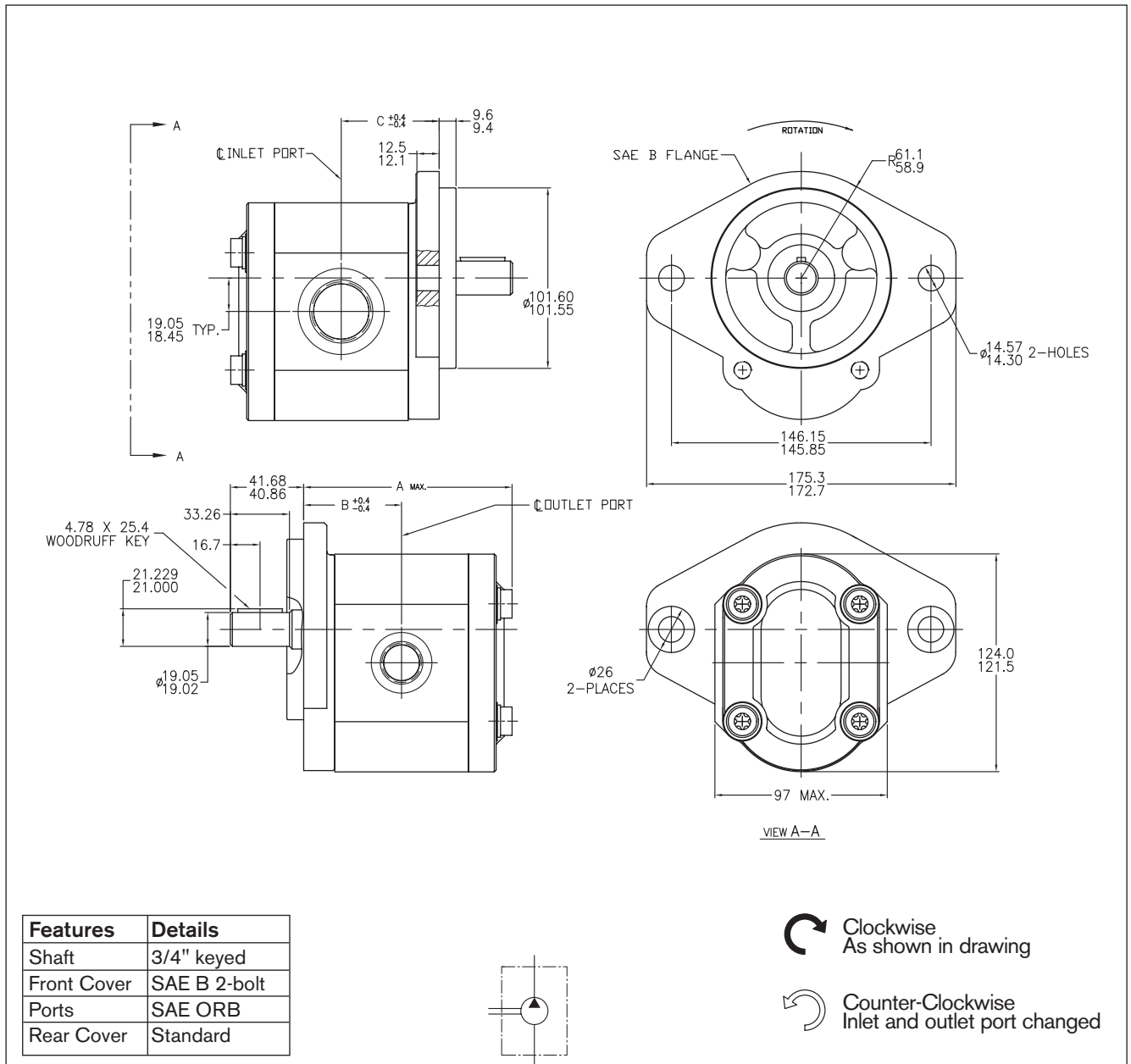

**Ordering code**

**AZPN - X X - □ □ □ □ Q C 12 MB**

Displacement [cm <sup>3</sup> /rev]	Ordering-Number *		Max. operating pressure [bar]	Max. rotation speed [min <sup>-1</sup> ]	Dimension [mm]			Inlet Port ** (SAE O-Ring BOSS)	Outlet Port (SAE O-Ring BOSS)
	L	R			A	B	C		
20.0	<b>9 510 390 055</b>	<b>9 510 390 049</b>	230	3000	109.4	52.1	52.1	-16	-10
22.0	<b>9 510 390 056</b>	<b>9 510 390 050</b>	230	3000	112.4	53.6	53.6	-16	-10
25.0	<b>9 510 390 057</b>	<b>9 510 390 051</b>	230	3000	115.4	55.1	55.1	-20	-12
28.0	<b>9 510 390 058</b>	<b>9 510 390 052</b>	210	2800	118.4	56.6	56.6	-20	-12
32.0	<b>9 510 390 059</b>	<b>9 510 390 053</b>	180	2800	122.5	58.8	58.8	-20	-12
36.0	<b>9 510 390 060</b>	<b>9 510 390 054</b>	160	2600	127.0	61.1	61.1	-20	-12

\* Contact factory for availability of units with no ordering number listed.

\*\* Refer to page 46 for SAE O-Ring Boss Specifications and Dimensions.

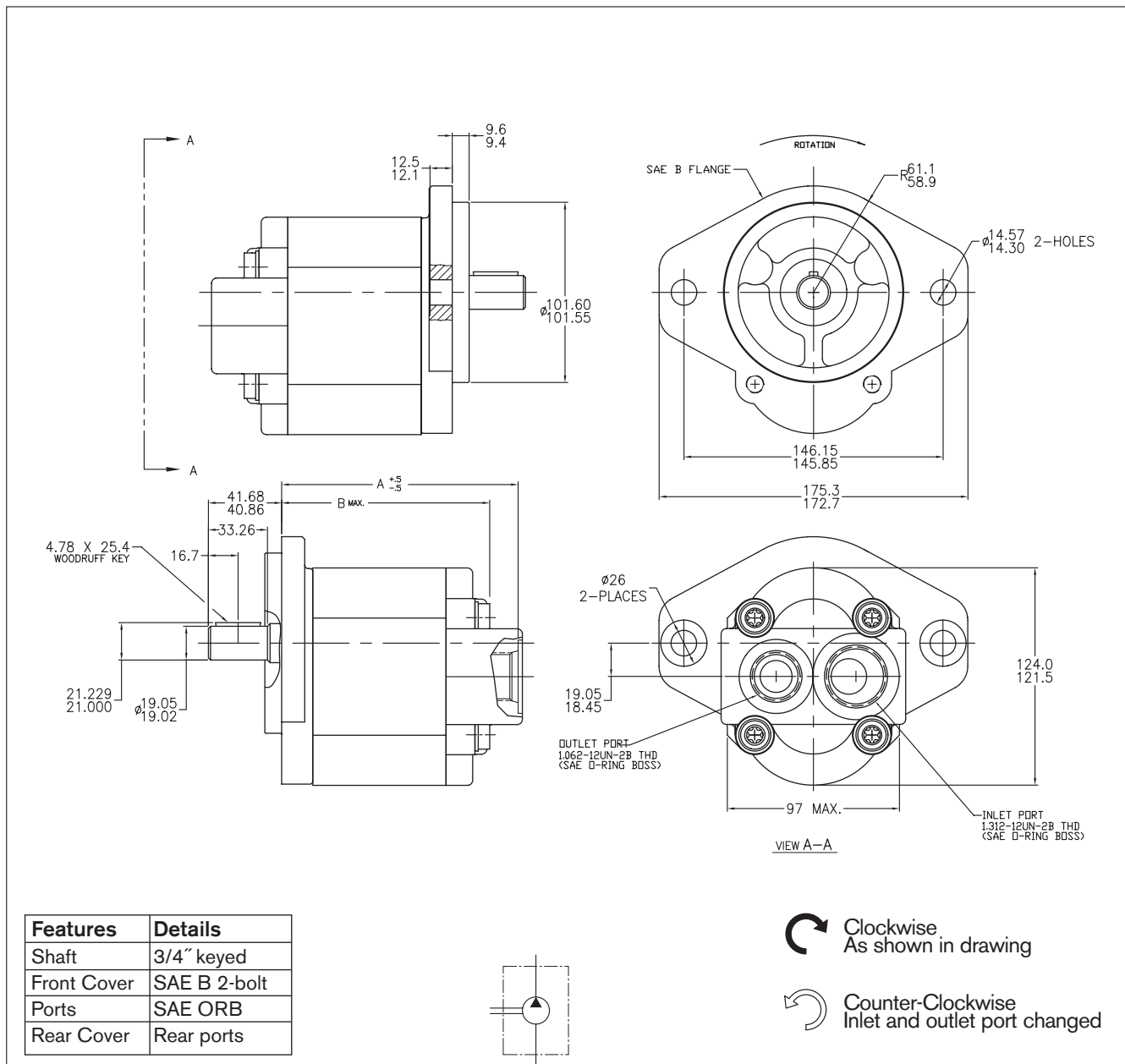

**Ordering code**

**AZPN - X X - □ □ □ □ Q C 12 MA**

Displacement [cm³/rev]	Ordering-Number *		Max. operating pressure [bar]	Max. rotation speed [min⁻¹]	Dimension [mm]		Inlet Port ** (SAE O-Ring BOSS)	Outlet Port (SAE O-Ring BOSS)
	L	R			A	B		
20.0	9 510 390 067	9 510 390 061	230	3000	128.1	110.0	-16	-12
22.0	9 510 390 068	9 510 390 062	230	3000	131.1	114.9	-16	-12
25.0	9 510 390 069	9 510 390 063	230	3000	134.1	116.0	-16	-12
28.0	9 510 390 070	9 510 390 064	210	2800	137.1	119.0	-16	-12
32.0	9 510 390 071	9 510 390 065	180	2800	141.6	123.5	-16	-12
36.0	9 510 390 072	9 510 390 066	160	2600	146.1	129.9	-16	-12

\* Contact factory for availability of units with no ordering number listed.  
 \*\* Refer to page 46 for SAE O-Ring Boss Specifications and Dimensions.

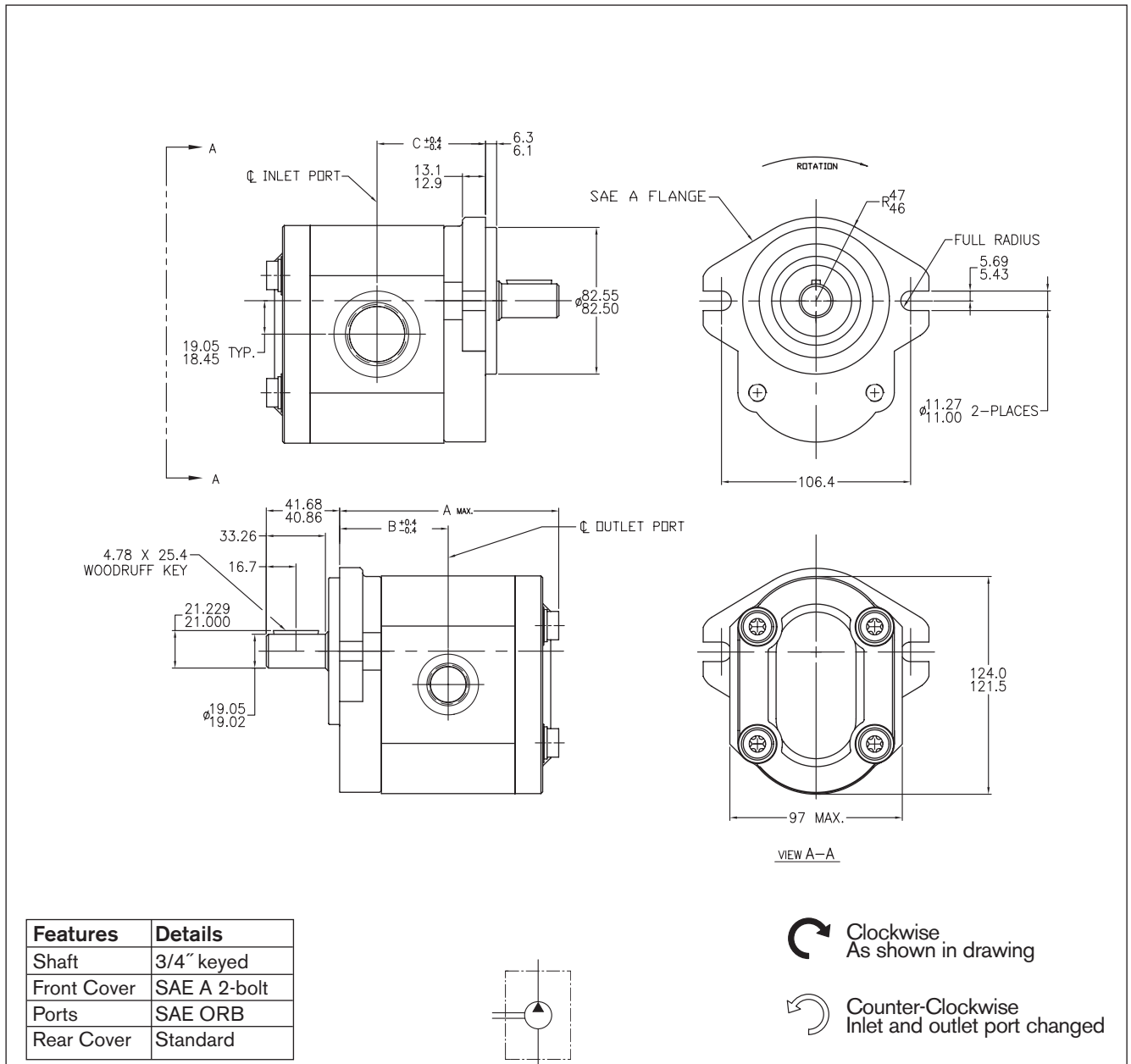

**Ordering code**

**AZPN - X X - □ □ □ □ Q R 12 MB**

Displacement [cm <sup>3</sup> /rev]	Ordering-Number *		Max. operating pressure [bar]	Max. rotation speed [min <sup>-1</sup> ]	Dimension [mm]			Inlet Port ** (SAE O-Ring BOSS)	Outlet Port (SAE O-Ring BOSS)
	L	R			A	B	C		
20.0	<b>9 510 390 079</b>	<b>9 510 390 073</b>	230	3000	115.4	58.1	58.1	-16	-10
22.0	<b>9 510 390 080</b>	<b>9 510 390 074</b>	230	3000	118.4	59.6	59.6	-16	-10
25.0	<b>9 510 390 081</b>	<b>9 510 390 075</b>	230	3000	121.4	61.1	61.1	-20	-12
28.0	<b>9 510 390 082</b>	<b>9 510 390 076</b>	210	2800	124.4	62.6	62.6	-20	-12
32.0	<b>9 510 390 083</b>	<b>9 510 390 077</b>	180	2800	128.5	64.8	64.8	-20	-12
36.0	<b>9 510 390 084</b>	<b>9 510 390 078</b>	160	2600	133.0	67.1	67.1	-20	-12

\* Contact factory for availability of units with no ordering number listed.

\*\* Refer to page 46 for SAE O-Ring Boss Specifications and Dimensions.

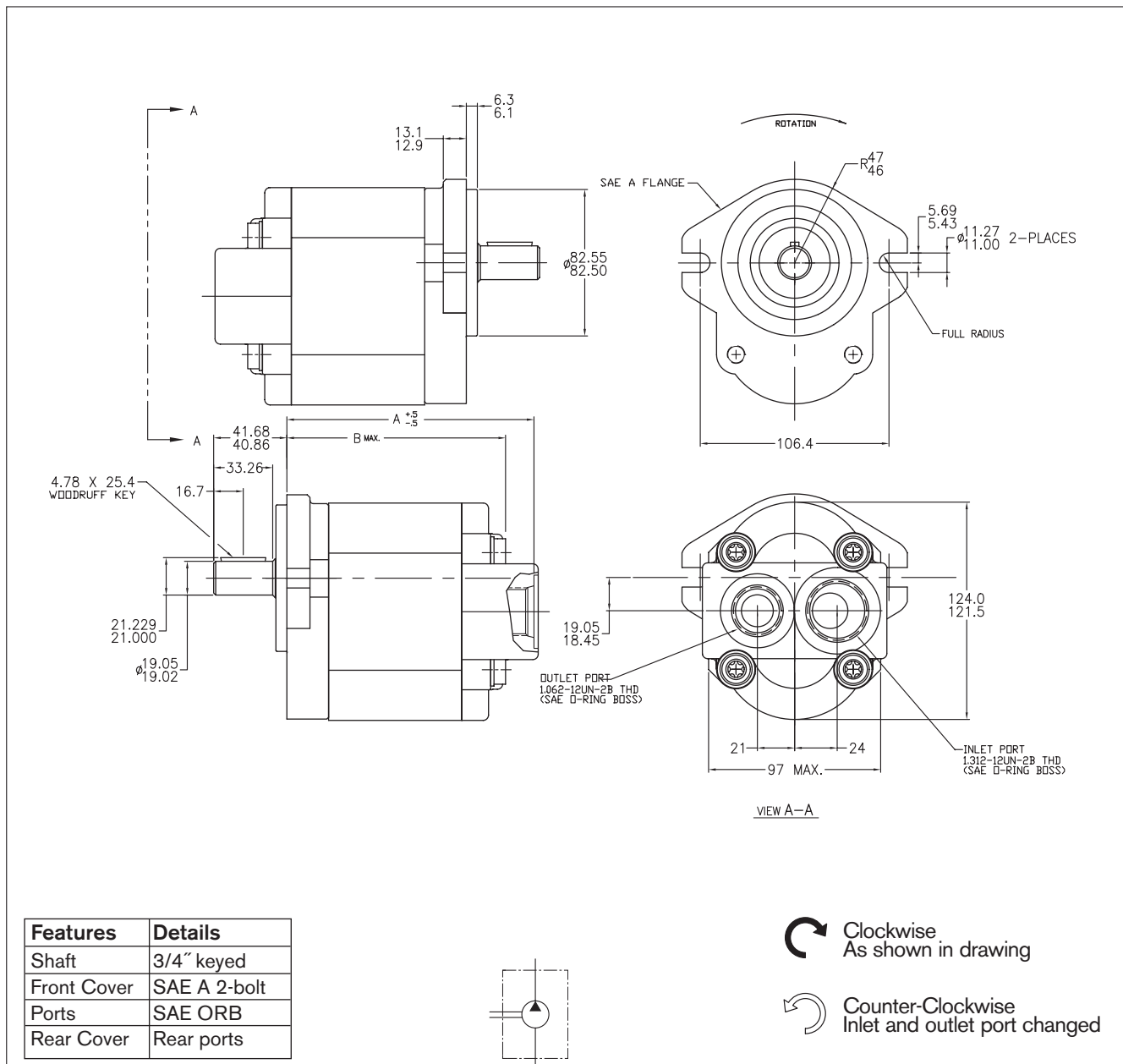

**Ordering code**

**AZPN - X X - □ □ □ □ Q R 12 MA**

Displacement [cm³/rev]	Ordering-Number *		Max. operating pressure [bar]	Max. rotation speed [min⁻¹]	Dimension [mm]		Inlet Port ** (SAE O-Ring BOSS)	Outlet Port (SAE O-Ring BOSS)
	L	R			A	B		
20.0	<b>9 510 390 128</b>	<b>9 510 390 122</b>	230	3000	115.4	58.1	-16	-12
22.0	<b>9 510 390 129</b>	<b>9 510 390 123</b>	230	3000	118.4	59.6	-16	-12
25.0	<b>9 510 390 130</b>	<b>9 510 390 124</b>	230	3000	121.4	61.1	-16	-12
28.0	<b>9 510 390 131</b>	<b>9 510 390 125</b>	210	2800	124.4	62.6	-16	-12
32.0	<b>9 510 390 132</b>	<b>9 510 390 126</b>	180	2800	128.5	64.8	-16	-12
36.0	<b>9 510 390 133</b>	<b>9 510 390 127</b>	160	2600	133.0	67.1	-16	-12

\* Contact factory for availability of units with no ordering number listed.  
 \*\* Refer to page 46 for SAE O-Ring Boss Specifications and Dimensions.



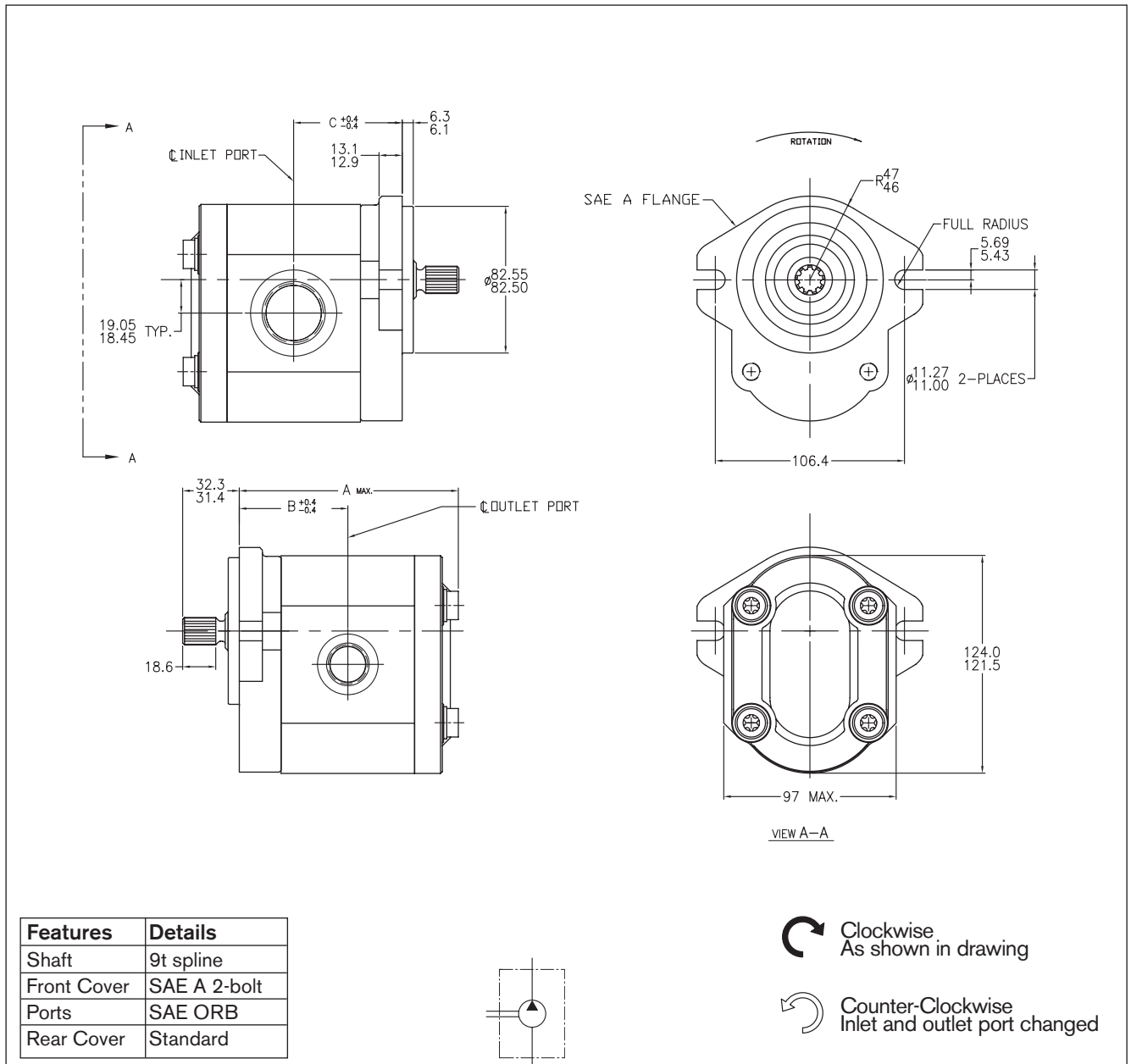

**Ordering code**

**AZPN - X X - □ □ □ □ R R 12 MB**

Displacement [cm <sup>3</sup> /rev]	Ordering-Number *		Max. operating pressure [bar]	Max. rotation speed [min <sup>-1</sup> ]	Dimension [mm]			Inlet Port ** (SAE O-Ring BOSS)	Outlet Port (SAE O-Ring BOSS)
	L	R			A	B	C		
20.0	<b>9 510 390 031</b>	<b>9 510 390 025</b>	230	3000	117.7	58.1	58.1	-16	-10
22.0	<b>9 510 390 032</b>	<b>9 510 390 026</b>	230	3000	120.7	59.6	59.6	-16	-10
25.0	<b>9 510 390 033</b>	<b>9 510 390 027</b>	230	3000	123.7	61.1	61.1	-20	-12
28.0	<b>9 510 390 034</b>	<b>9 510 390 028</b>	210	2800	126.7	62.6	62.6	-20	-12
32.0	<b>9 510 390 035</b>	<b>9 510 390 029</b>	180	2800	130.8	64.8	64.8	-20	-12
36.0	<b>9 510 390 036</b>	<b>9 510 390 030</b>	160	2600	135.3	67.1	67.1	-20	-12

\* Contact factory for availability of units with no ordering number listed.

\*\* Refer to page 46 for SAE O-Ring Boss Specifications and Dimensions.

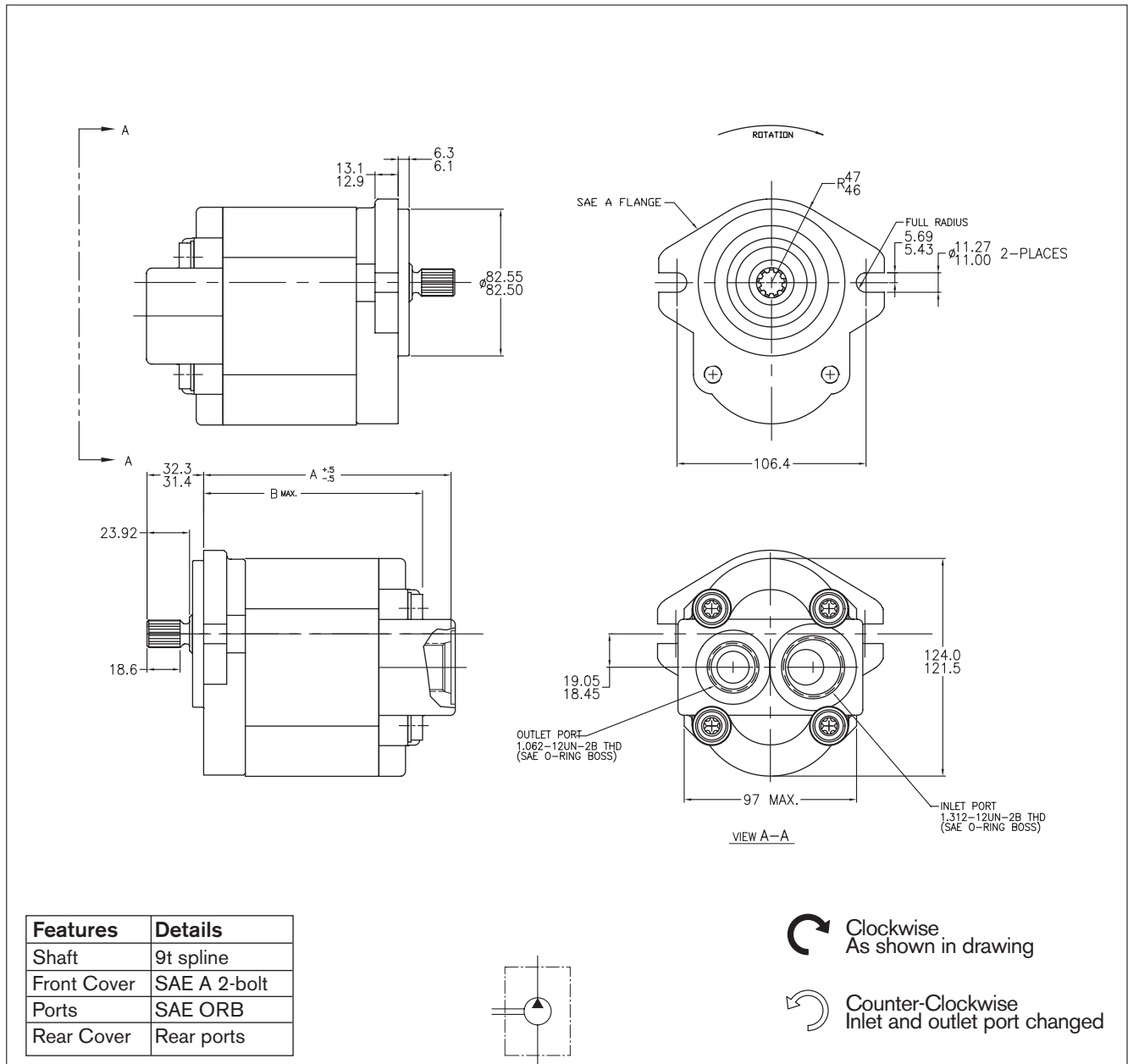

**Ordering code**

**AZPN - X X - □ □ □ □ R R 12 MA**

Displacement [cm <sup>3</sup> /rev]	Ordering-Number *		Max. operating pressure [bar]	Max. rotation speed [min <sup>-1</sup> ]	Dimension [mm]		Inlet Port ** (SAE O-Ring BOSS)	Outlet Port (SAE O-Ring BOSS)
	L	R			A	B		
20.0	9 510 390 043	9 510 390 037	230	3000	134.1	116.0	-16	-12
22.0	9 510 390 044	9 510 390 038	230	3000	131.1	120.9	-16	-12
25.0	9 510 390 045	9 510 390 039	230	3000	140.1	122.0	-16	-12
28.0	9 510 390 046	9 510 390 040	210	2800	143.1	125.0	-16	-12
32.0	9 510 390 047	9 510 390 041	180	2800	147.6	129.5	-16	-12
36.0	9 510 390 048	9 510 390 042	160	2600	152.1	135.9	-16	-12

\* Contact factory for availability of units with no ordering number listed.  
 \*\* Refer to page 46 for SAE O-Ring Boss Specifications and Dimensions.

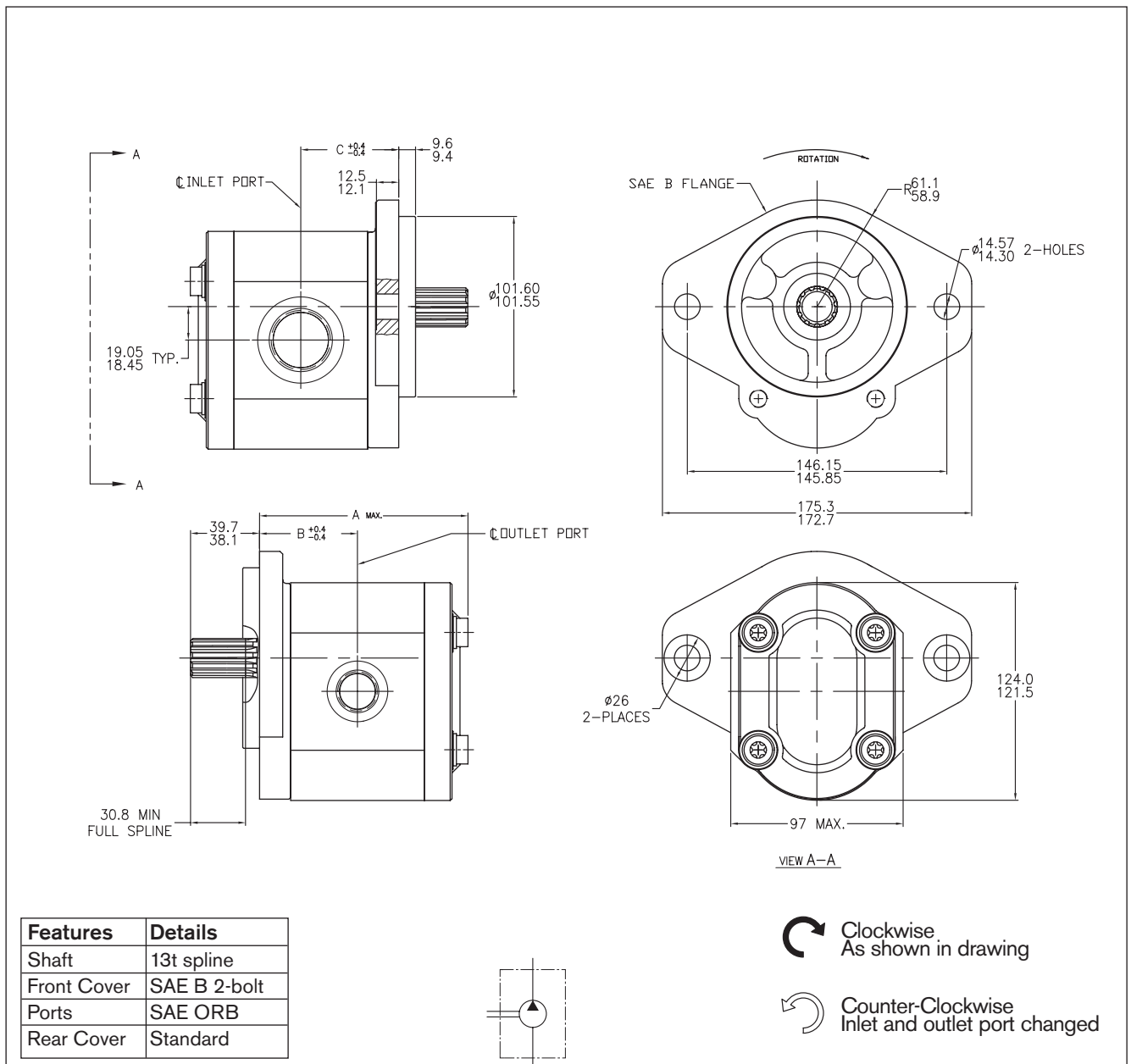

**Ordering code**

**AZPN - X X - □ □ □ □ D C 12 MB**

Displacement [cm <sup>3</sup> /rev]	Ordering-Number *		Max. operating pressure [bar]	Max. rotation speed [min <sup>-1</sup> ]	Dimension [mm]			Inlet Port ** (SAE O-Ring BOSS)	Outlet Port (SAE O-Ring BOSS)
	L	R			A	B	C		
20.0	<b>9 510 390 007</b>	<b>9 510 390 001</b>	230	3000	109.8	52.1	52.1	-16	-10
22.0	<b>9 510 390 008</b>	<b>9 510 390 002</b>	230	3000	114.7	53.6	53.6	-16	-10
25.0	<b>9 510 390 009</b>	<b>9 510 390 003</b>	230	3000	115.8	55.1	55.1	-20	-12
28.0	<b>9 510 390 010</b>	<b>9 510 390 004</b>	210	2800	118.8	56.6	56.6	-20	-12
32.0	<b>9 510 390 011</b>	<b>9 510 390 005</b>	180	2800	123.3	58.8	58.8	-20	-12
36.0	<b>9 510 390 012</b>	<b>9 510 390 006</b>	160	2600	129.7	61.1	61.1	-20	-12

\* Contact factory for availability of units with no ordering number listed.

\*\* Refer to page 46 for SAE O-Ring Boss Specifications and Dimensions.

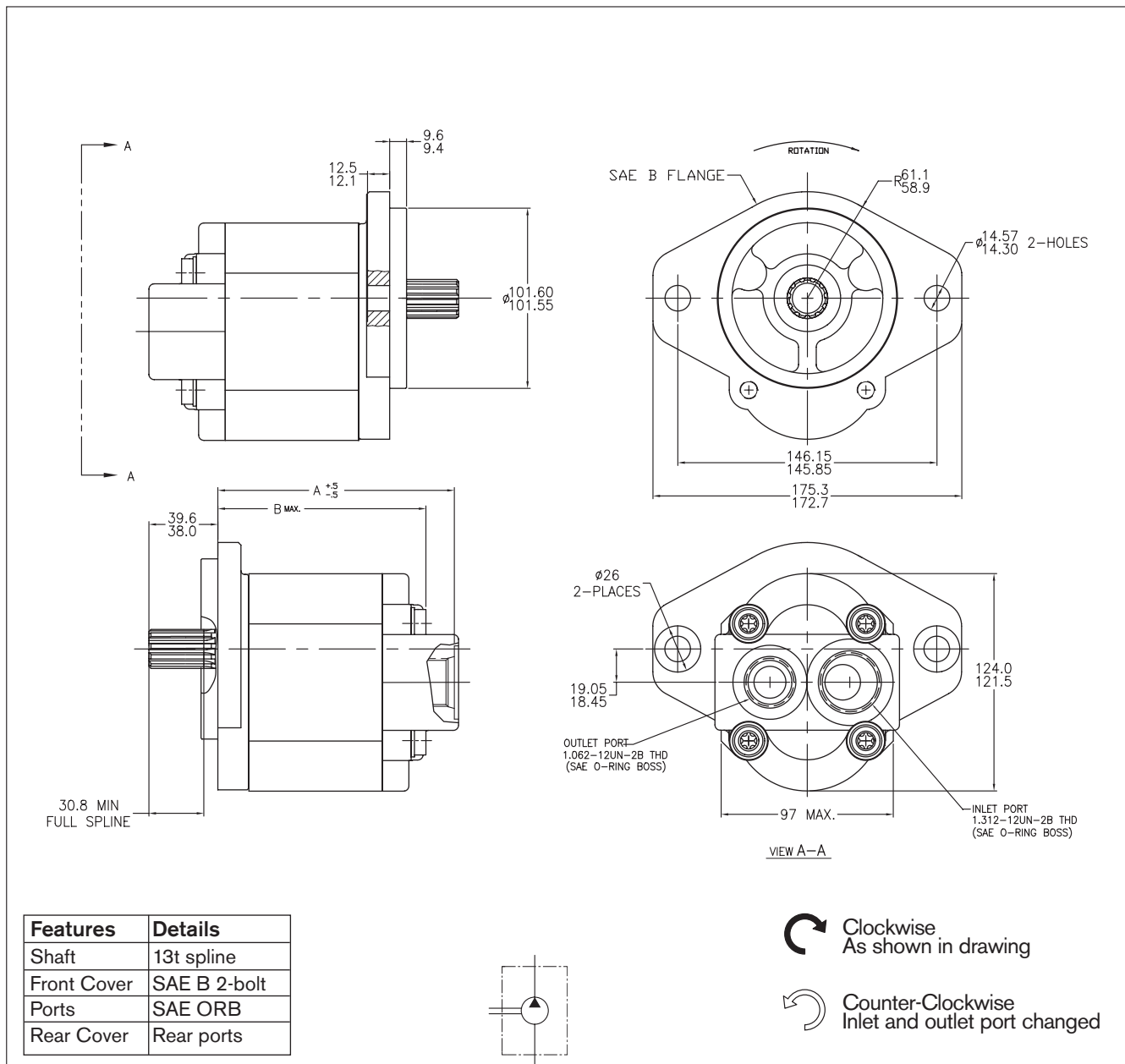

**Ordering code**  
**AZPN - X X - □ □ □ □ D C 12 MA**

Displacement [cm <sup>3</sup> /rev]	Ordering-Number *		Max. operating pressure [bar]	Max. rotation speed [min <sup>-1</sup> ]	Dimension [mm]		Inlet Port ** (SAE O-Ring BOSS)	Outlet Port (SAE O-Ring BOSS)
	L	R			A	B		
20.0	9 510 390 019	9 510 390 013	230	3000	128.1	110.0	-16	-12
22.0	9 510 390 020	9 510 390 014	230	3000	131.1	114.9	-16	-12
25.0	9 510 390 021	9 510 390 015	230	3000	134.1	116.0	-16	-12
28.0	9 510 390 022	9 510 390 016	210	2800	137.1	119.0	-16	-12
32.0	9 510 390 023	9 510 390 017	180	2800	141.6	123.5	-16	-12
36.0	9 510 390 024	9 510 390 018	160	2600	146.1	129.9	-16	-12

\* Contact factory for availability of units with no ordering number listed.  
 \*\* Refer to page 46 for SAE O-Ring Boss Specifications and Dimensions.

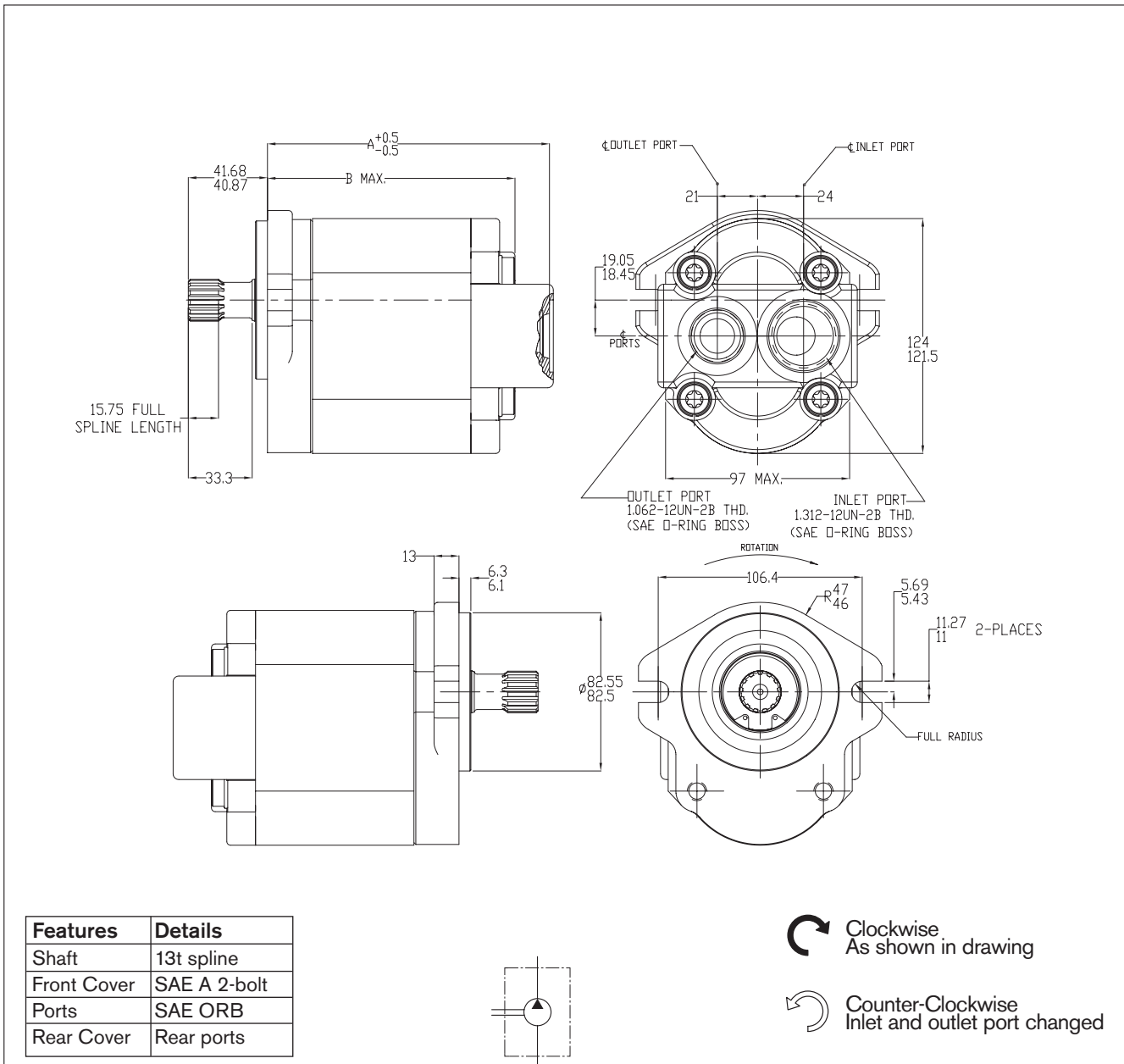

**Ordering code**

AZPN - X X - □ □ □ □ D R 12 MA

Displacement [cm <sup>3</sup> /rev]	Ordering-Number *		Max. operating pressure [bar]	Max. rotation speed [min <sup>-1</sup> ]	Dimension [mm]		Inlet Port ** (SAE O-Ring BOSS)	Outlet Port (SAE O-Ring BOSS)
	L	R			A	B		
20.0	*	<b>9 510 390 175</b>	230	3000	133.6	116.0	-16	-12
22.0	<b>9 510 390 188</b>	<b>9 510 390 176</b>	230	3000	136.6	119.0	-16	-12
25.0	*	<b>9 510 390 177</b>	230	3000	139.6	124.0	-16	-12
28.0	*	<b>9 510 390 178</b>	210	2800	142.6	125.0	-16	-12
32.0	*	<b>9 510 390 179</b>	180	2800	147.1	129.5	-16	-12
36.0	*	<b>9 510 390 180</b>	160	2600	151.6	134.0	-16	-12

\* Contact factory for availability of units with no ordering number listed.  
 \*\* Refer to page 46 for SAE O-Ring Boss Specifications and Dimensions.

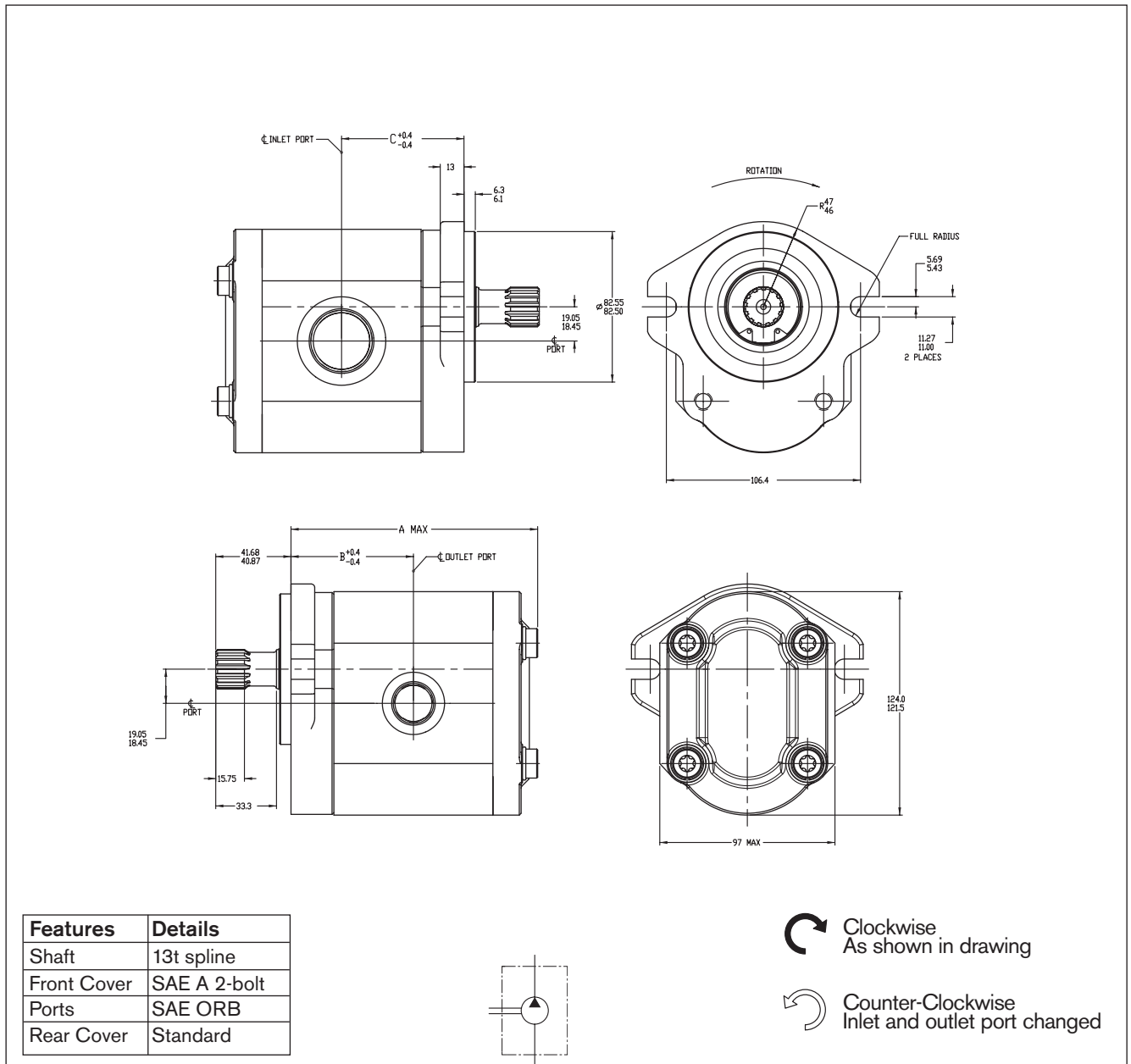

**Ordering code**

**AZPN - X X - □ □ □ □ D R 12 MB**

Displacement [cm <sup>3</sup> /rev]	Ordering-Number *		Max. operating pressure [bar]	Max. rotation speed [min <sup>-1</sup> ]	Dimension [mm]			Inlet Port ** (SAE O-Ring BOSS)	Outlet Port (SAE O-Ring BOSS)
	L	R			A	B	C		
20.0	*	*							
22.0	*	*							
25.0	*	*							
28.0	<b>9 510 390 174</b>	*	210	2800	124.7	62.8	62.8	-20	-12
32.0	*	<b>9 510 390 173</b>	180	2800	129.3	64.8	64.8	-20	-12
36.0	*	<b>9 510 390 190</b>	160	2600	135.7	67.1	67.1	-20	-12

\* Contact factory for availability of units with no ordering number listed.

\*\* Refer to page 46 for SAE O-Ring Boss Specifications and Dimensions.

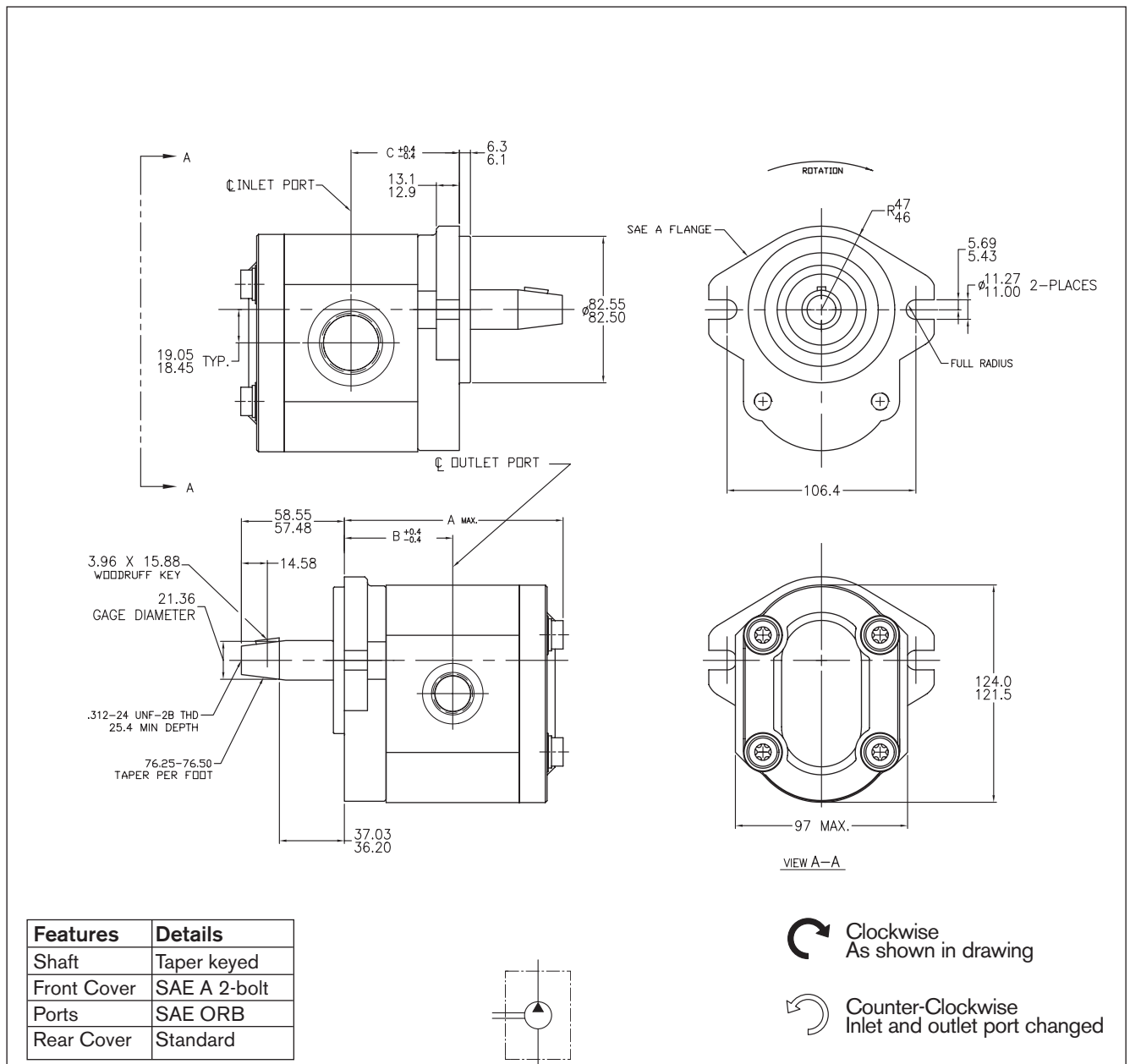

**Ordering code**

**AZPN - X X - □ □ □ X R 12 MB-S0075**

Displacement [cm <sup>3</sup> /rev]	Ordering-Number *		Max. operating pressure [bar]	Max. rotation speed [min <sup>-1</sup> ]	Dimension [mm]			Inlet Port ** (SAE O-Ring BOSS)	Outlet Port (SAE O-Ring BOSS)
	L	R			A	B	C		
20.0	<b>9 510 390 116</b>	<b>9 510 390 110</b>	230	3000	115.8	58.1	58.1	-16	-10
22.0	<b>9 510 390 117</b>	<b>9 510 390 111</b>	230	3000	120.7	59.6	59.6	-16	-10
25.0	<b>9 510 390 118</b>	<b>9 510 390 112</b>	230	3000	121.8	61.1	61.1	-20	-12
28.0	<b>9 510 390 119</b>	<b>9 510 390 113</b>	210	2800	124.8	62.6	62.6	-20	-12
32.0	<b>9 510 390 120</b>	<b>9 510 390 114</b>	180	2800	129.3	64.8	64.8	-20	-12
36.0	<b>9 510 390 121</b>	<b>9 510 390 115</b>	160	2600	135.7	67.1	67.1	-20	-12

\* Contact factory for availability of units with no ordering number listed.

\*\* Refer to page 46 for SAE O-Ring Boss Specifications and Dimensions.

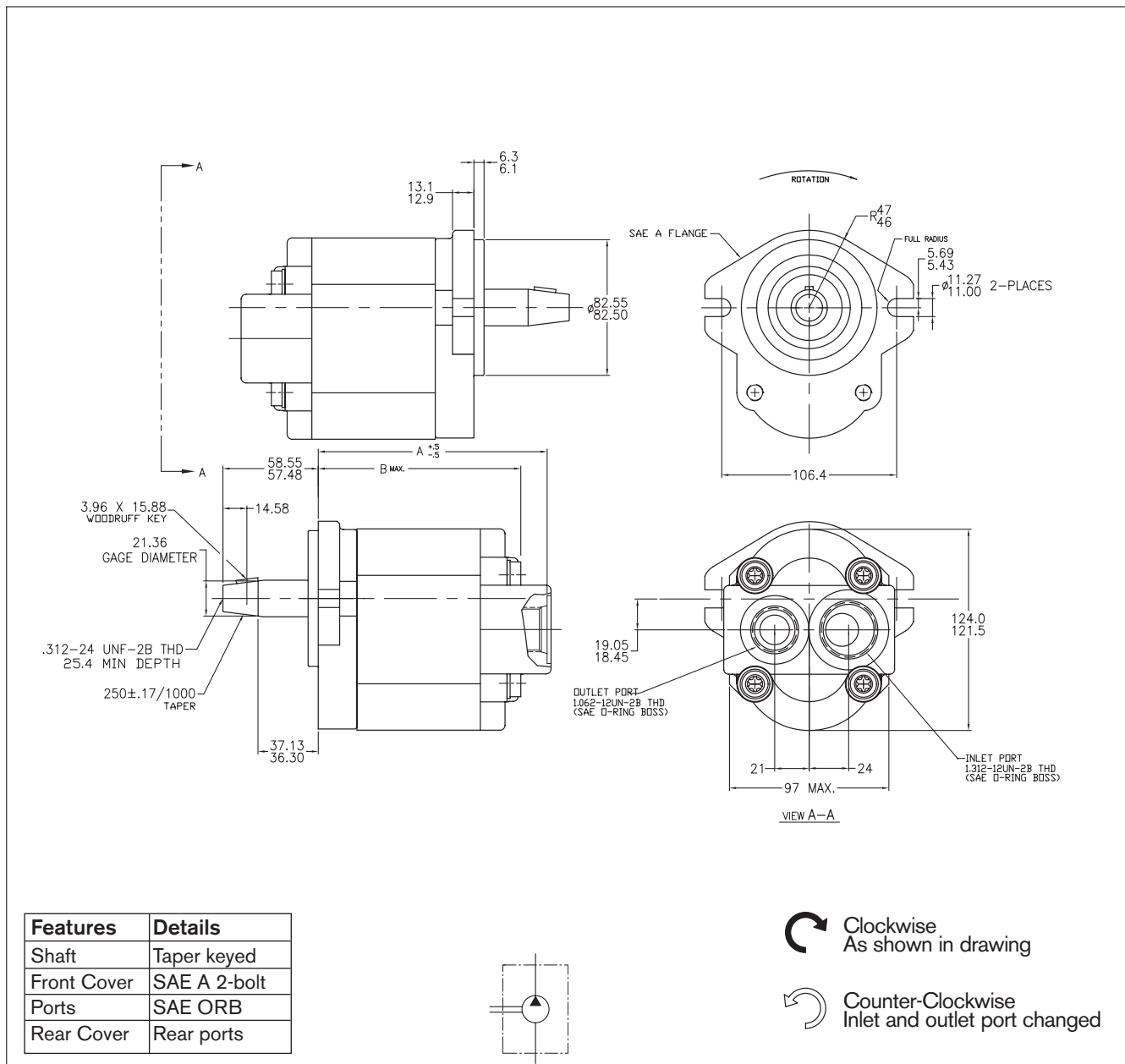

**Ordering code**

**AZPN - X X - □ □ □ X R 12 MA-S0075**

Displacement [cm <sup>3</sup> /rev]	Ordering-Number *		Max. operating pressure [bar]	Max. rotation speed [min <sup>-1</sup> ]	Dimension [mm]		Inlet Port ** (SAE O-Ring BOSS)	Outlet Port (SAE O-Ring BOSS)
	L	R			A	B		
20.0	9 510 390 140	9 510 390 134	230	3000	134.1	116.0	-16	-12
22.0	9 510 390 141	9 510 390 135	230	3000	137.1	120.9	-16	-12
25.0	9 510 390 142	9 510 390 136	230	3000	140.1	122.0	-16	-12
28.0	9 510 390 143	9 510 390 137	210	2800	143.1	125.0	-16	-12
32.0	9 510 390 144	9 510 390 138	180	2800	147.6	129.5	-16	-12
36.0	9 510 390 145	9 510 390 139	160	2600	152.1	135.9	-16	-12

\* Contact factory for availability of units with no ordering number listed.  
 \*\* Refer to page 46 for SAE O-Ring Boss Specifications and Dimensions.



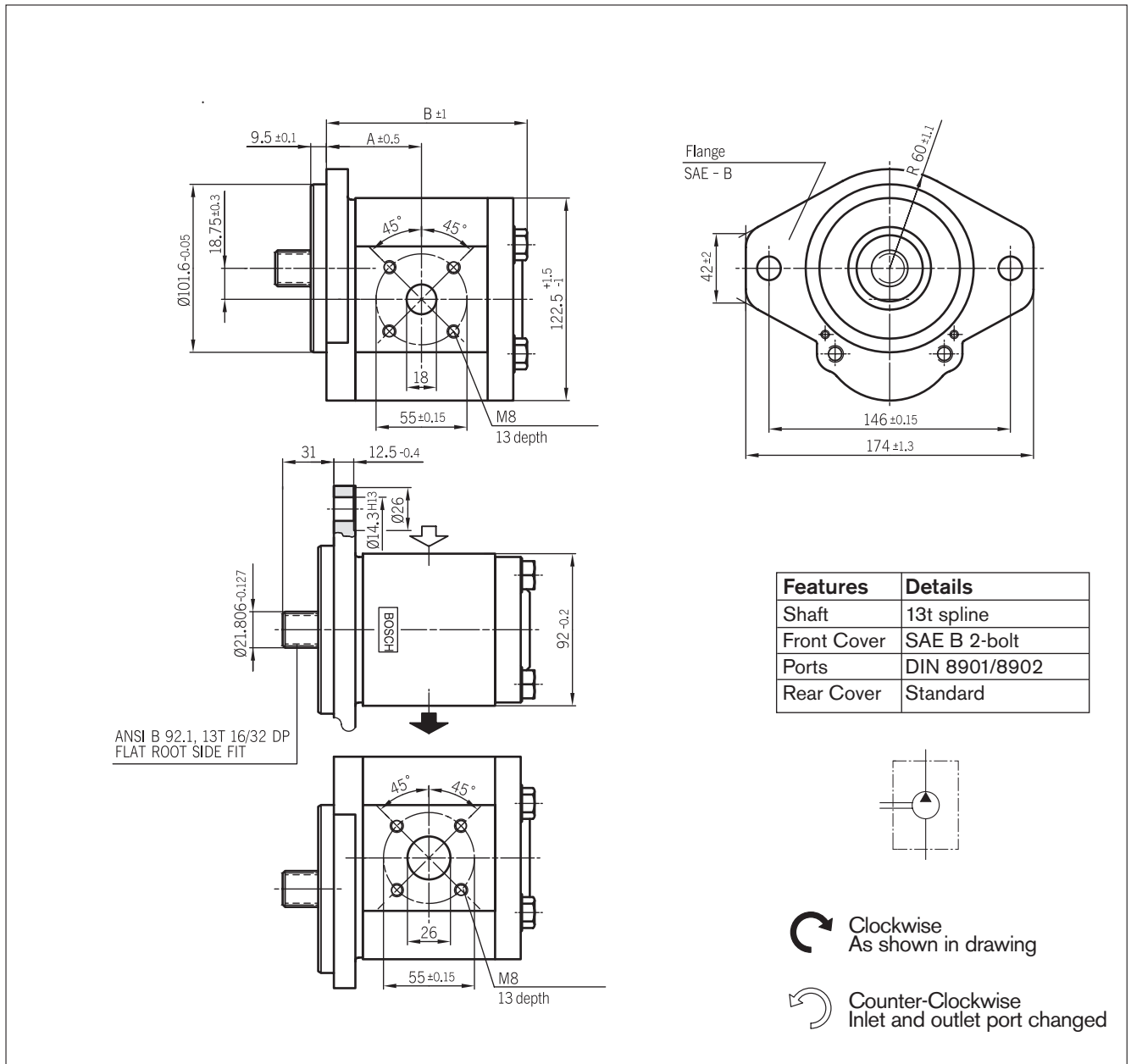

**Ordering code**

**AZPN - X X - □ □ □ □ D C 20 MB**

Displacement [cm <sup>3</sup> /rev]	Ordering-Number *		Max. operating pressure [bar]	Max. rotation speed [min <sup>-1</sup> ]	Dimension [mm]					
	L	R			A	B				
25.0	<b>0 510 725 377</b>	<b>0 510 725 057</b>	230	3000	55.0	116.1				
28.0		<b>0 510 725 058</b>	210	2800	56.5	119.1				
36.0	<b>0 510 725 363</b>		160	2600	61.0	128.1				

\* Contact factory for availability of units with no ordering number listed.  
 \*\* Refer to page 46 for SAE O-Ring Boss Specifications and Dimensions.

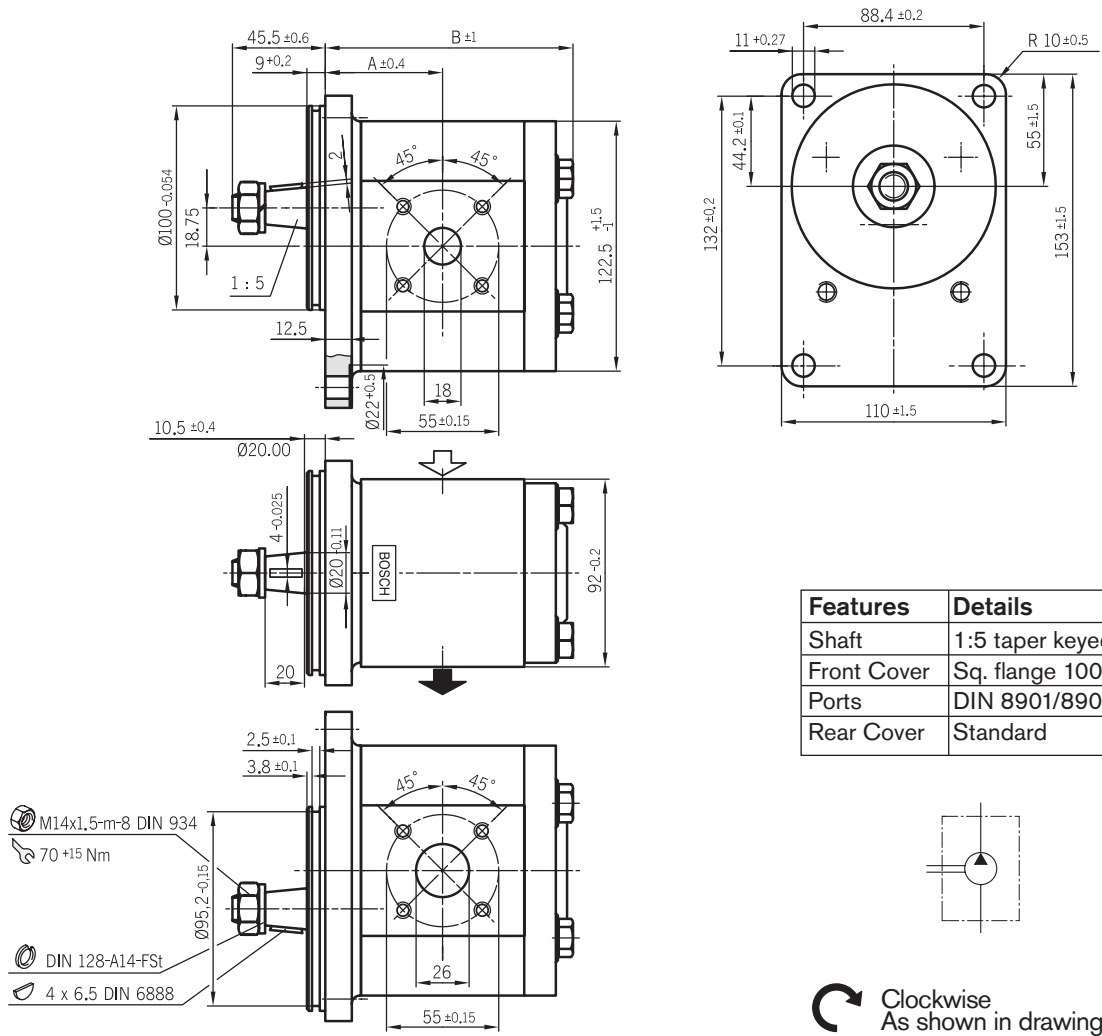

Features	Details
Shaft	1:5 taper keyed
Front Cover	Sq. flange 100mm
Ports	DIN 8901/8902
Rear Cover	Standard

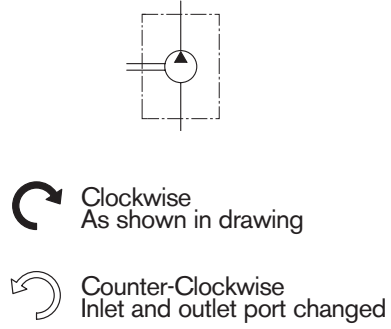

**Ordering code**  
**AZPN - X X - □ □ □ □ C B 20 MB**

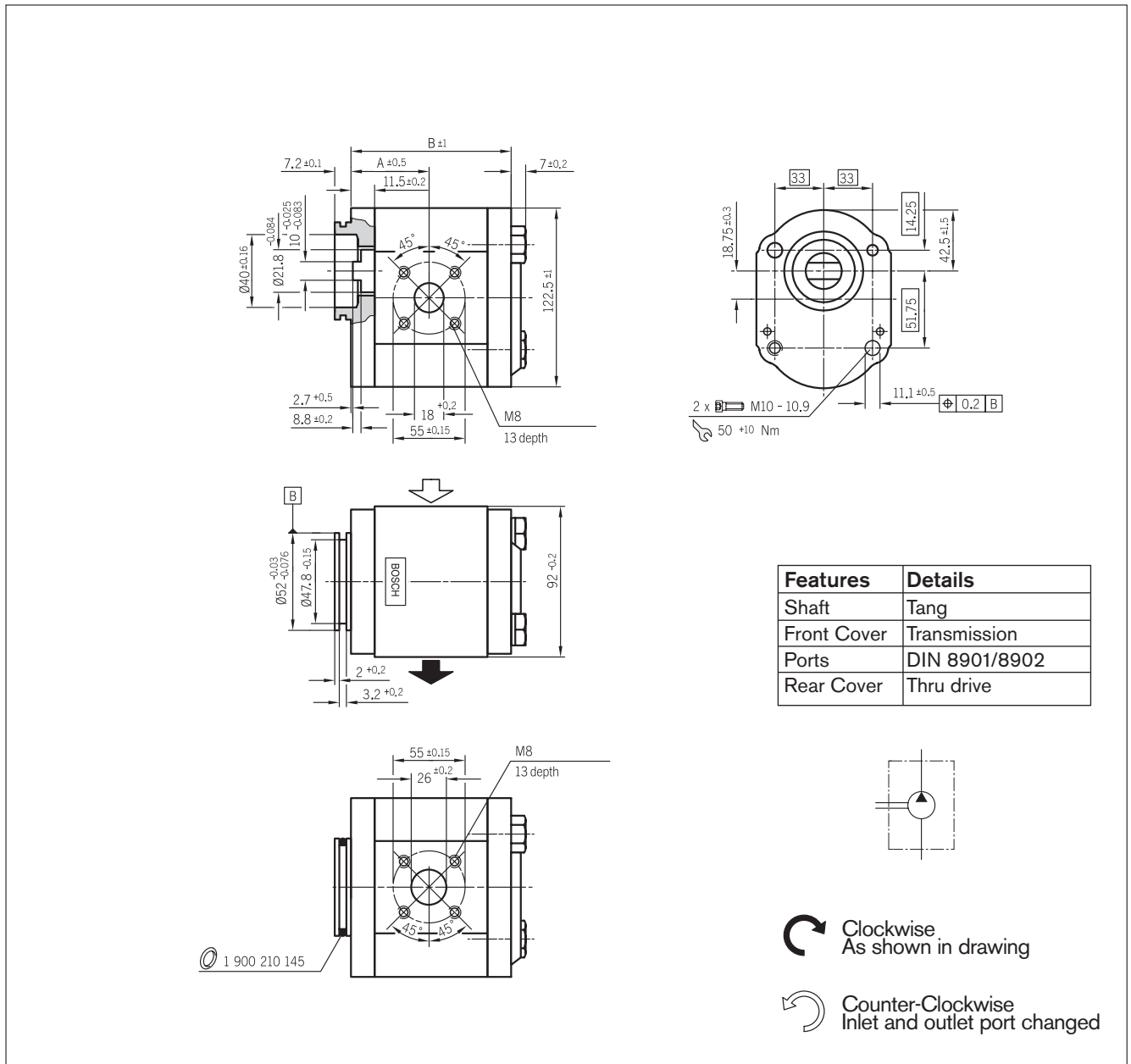

Displacement [cm <sup>3</sup> /rev]	Ordering-Number *		Max. operating pressure [bar]	Max. rotation speed [min <sup>-1</sup> ]	Dimension [mm]				
	L	R			A	B			
20.0	<b>0 510 625 335</b>	<b>0 510 625 035</b>	230	3000	52.0	109.8			
25.0	<b>0 510 725 352</b>	<b>0 510 725 047</b>	230	3000	55.0	115.8			
28.0	<b>0 510 725 364</b>	<b>0 510 725 055</b>	210	2800	56.5	118.8			
32.0	<b>0 510 725 353</b>	<b>0 510 725 048</b>	180	2800	59.0	123.3			

\* Contact factory for availability of units with no ordering number listed.



















**Ordering code**

**AZPN - X X - □ □ □ □ N M 20 MB**

Displacement [cm <sup>3</sup> /rev]	Ordering-Number *		Max. operating pressure [bar]	Max. rotation speed [min <sup>-1</sup> ]	Dimension [mm]	
	 L	 R			A	B
25.0		<b>0 510 715 006</b>	230	3000	55.0	109.1
32.0		<b>0 510 715 007</b>	180	2800	59.0	116.6

\* Contact factory for availability of units with no ordering number listed.

# Ordering Code (G Series Pump)

<b>A Z</b>			<b>P</b>	<b>G - 22 - 045 - R</b>			<b>D</b>	<b>C</b>	<b>12</b>	<b>M</b>	<b>B</b>
<b>Function</b>											
P = Pump											
<b>Size (G)</b>											
1.99in <sup>3</sup> (32.6 cm <sup>3</sup> ) = 032											
2.20in <sup>3</sup> (36.0 cm <sup>3</sup> ) = 036											
2.75in <sup>3</sup> (45.0 cm <sup>3</sup> ) = 045											
3.42in <sup>3</sup> (56.0 cm <sup>3</sup> ) = 056											
3.84in <sup>3</sup> (63.0 cm <sup>3</sup> ) = 063											
<b>Direction of rotation</b>											
Right = R											
Left = L											
									<b>End cover</b>		
									Standard = B		
									<b>Seals</b>		
									NBR = M		
									FPM = P		
									NBR, shaft seal in FPM = K		
<b>Drive shafts</b>				<b>Front flange</b>				<b>Line connections</b>			
				Matching front flange							
<b>C</b>	Conical 1:5 (Tapered key)		<b>B</b>	<b>B</b>	Square flange Pilot Ø 105 mm		<b>20</b>	Rectangular flange			
<b>S</b>	Conical 1:5 for flange A (Tapered key)		<b>A</b>	<b>O</b>	Square flange Pilot Ø 50.78 mm		<b>30</b>	Rectangular flange			
<b>H</b>	Conical 1:8 (Tapered key)		<b>O</b>	<b>C</b>	SAE B 2-bolt		<b>07</b>	Split flange SAE Code 61 Metric bolts			
<b>N</b>	Dog (Tang)		<b>M</b>	<b>M</b>	Transmission flange Pilot Ø 52 mm with O-ring		<b>40</b>	Split flange SAE Code 61 UNC bolts			
<b>Q</b>	Cylindrical (Straight Key) SAE B 7/8"		<b>C</b>	<b>A</b>	Outrigger bearing Pilot Ø 105 mm (outboard bearing)		<b>12</b>	Thread (UN-23) SAE O-Ring BOSS			
<b>D</b>	Spline shaft SAE B 13T		<b>C</b>								
<b>F</b>	Spline shaft DIN 5482 B17x14		<b>B</b>								

Note: Consult Factory for Availability

Size **G**

**4 ... 28 cm<sup>3</sup>/rev**

Check sizes

### N Series Pump Product Index

(Reference page 43 for ordering code designators)



Page Number	Shaft Ordering code	Mounting Type	Flange	Port Ports	Orientation
73	AZPG-22-XXXXDC12MB	D	C	12	side
74	AZPG-22-XXXXDC12MA	D	C	12	rear
75	AZPG-22-XXXXQC12MB	Q	C	12	side
76	AZPG-22-XXXXQC12MA	Q	C	12	rear
77	AZPG-22-XXXXDC40MB	D	C	40	side
78	AZPG-22-XXXXQC40MB	Q	C	40	side

**G Series Performance Ratings**

Size		32	36	45	56	63
Displacement:	cm <sup>3</sup> /rev	32	36	45	56	63
	cu in/rev	1.95	2.20	2.75	3.42	3.84
Range Speed:	Min RPM	400	400	400	400	400
	Max RPM	2800	2800	2600	2300	2300
Pressure - Rated: p <sub>1</sub>	(Bar)	250	250	250	195	170
	(PSI)	3625	3625	3625	2828	2465
Intermittent: p <sub>2</sub>	(Bar)	280	280	280	225	200
	(PSI)	4060	4060	4060	3263	2900
Max Peak: p <sub>3</sub>	(Bar)	300	300	300	250	230
	(PSI)	4350	4350	4350	3625	3335
Inlet Pressure:	Continuous	0.7 - 3.0 bar absolute (9in Hg vacuum to 29 PSIG)				
	Intermittent	0.1 - 10 bar absolute (26in Hg vacuum to 130 PSIG)				

**G Series Pumps****SAE O-Ring BOSS - Standard Porting**

Displacement	Side Ports		Rear Port	
	Inlet	Outlet	Inlet	Outlet
32	-20	-16	-20	-16
36	-20	-16	-20	-16
45	-20	-16	-20	-16
56	-24	-20	-20	-16
63	-24	-20	-20	-16

**SAE Porting - Specifications and Dimensions  
per SAE J1926/1**

Dash Size	Thread Size (in)
-2	5/16-24 UNF-2B
-3	3/8-24 UNF-2B
-4	7/16-20 UNF-2B
-5	1/2-20 UNF-2B
-6	9/16-18 UNF-2B
-8	3/4-16 UNF-2B
-10	7/8-14 UNF-2B
-12	1-1/16-12 UN-2B
-14	1-3/16-12 UN-2B
-16	1-5/16-12 UN-2B
-20	1-5/8-12 UN-2B
-24	1-7/8-12 UN-2B
-32	2-1/2-12 UN-2B

**Split Flange SAE Porting - Specifications and Dimensions  
per SAE J518 (Code 61)**

Nominal Flange Size	Flange Dash Size	Port Diameter (max)	
		Inches	mm
1/2	-8	0.50	13
3/4	-12	0.75	19
1	-16	1.00	25
1-1/4	-20	1.25	32
1-1/2	-24	1.50	38
2	-32	2.00	51

Note: Ratings represent units incorporating SAE O-Ring BOSS threaded ports. Pressure ratings may differ for other types of ports.

**Diagrams**

Size **G**

$v = 35 \text{ mm}^2/\text{s}, T = 50 \text{ }^\circ\text{C}$

**Unit Conversions**

Pressure:  $\text{psi} = \text{bar} \times 14.7$   
 Torque:  $\text{ft-lbs} = (\text{Nm}) \times .738$   
 Power:  $\text{hp} = (\text{kW}) \times 1.341$   
 Volume:  $\text{in}^3 = (\text{cc}) \times 16.39$   
 $\text{gpm} = (\text{LPM}) \times .2642$

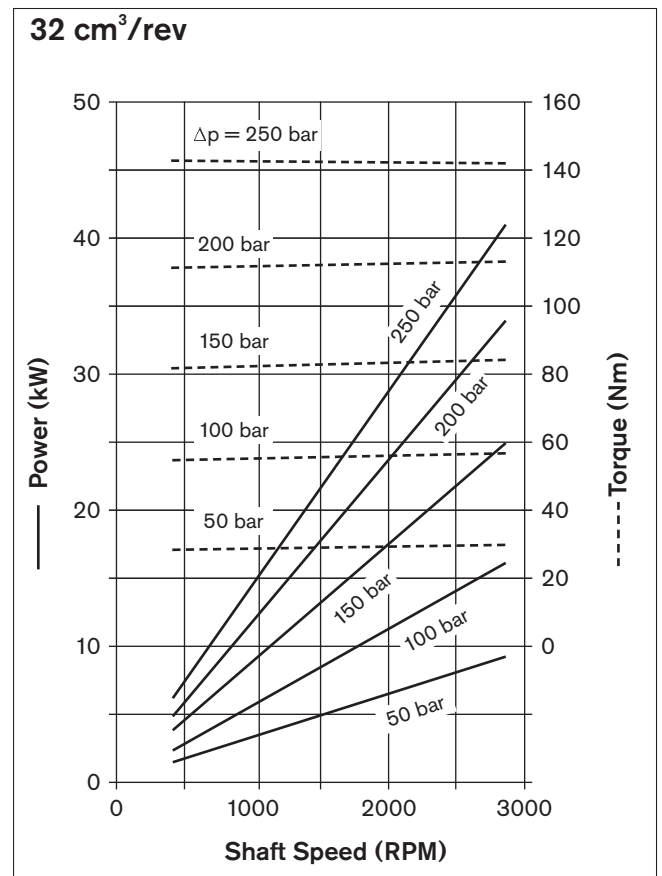
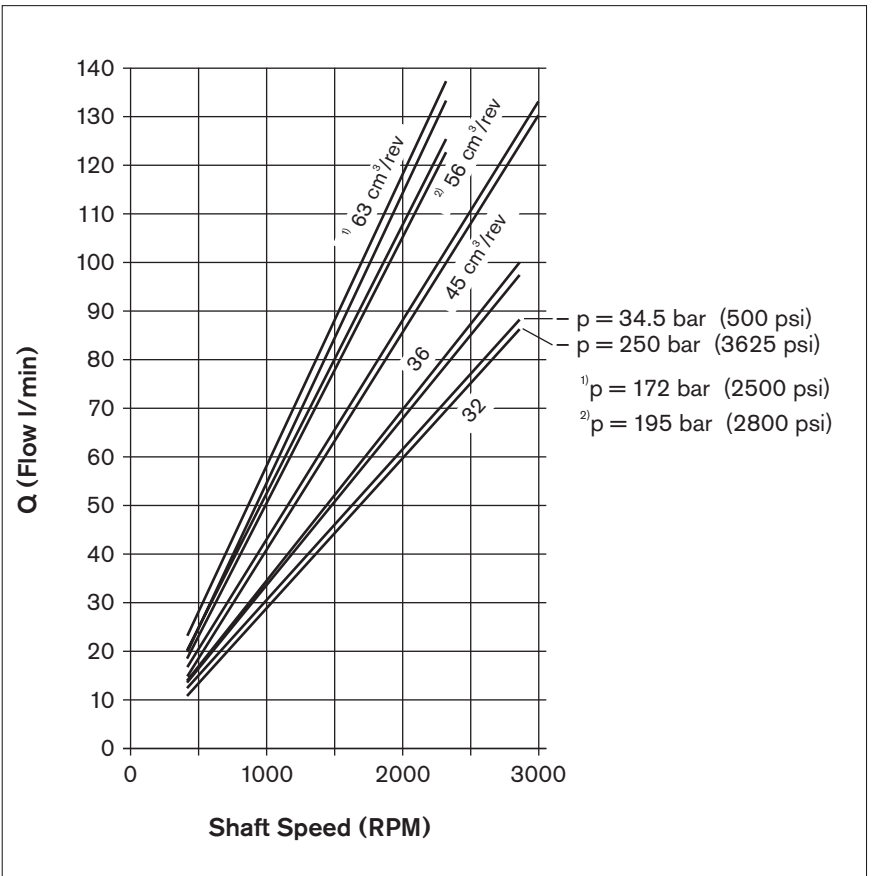

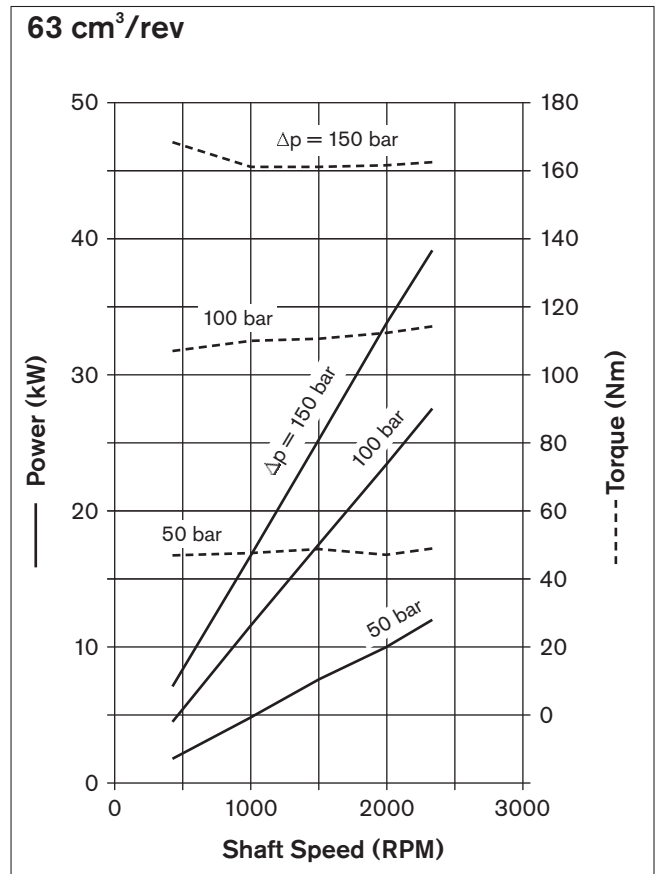
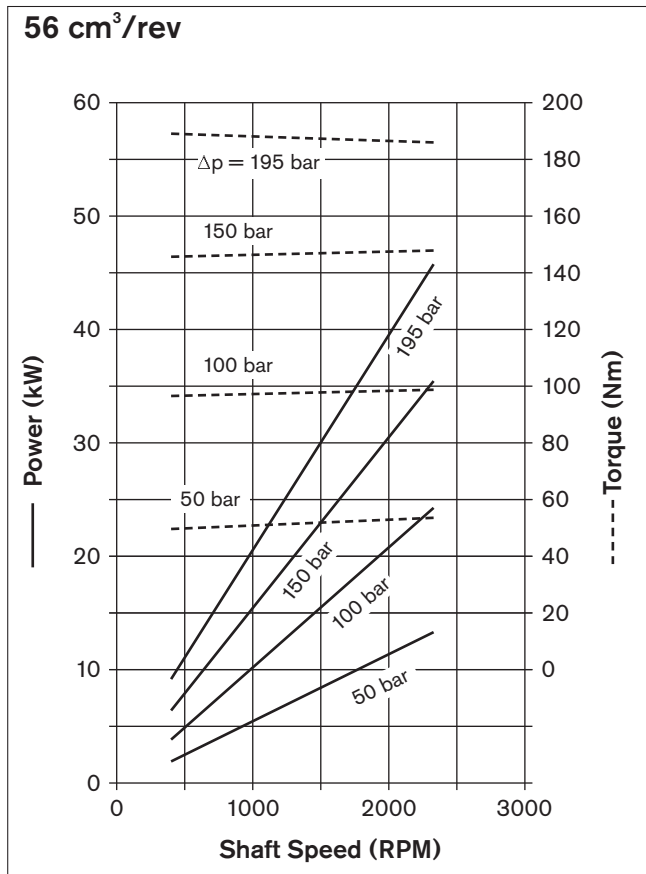
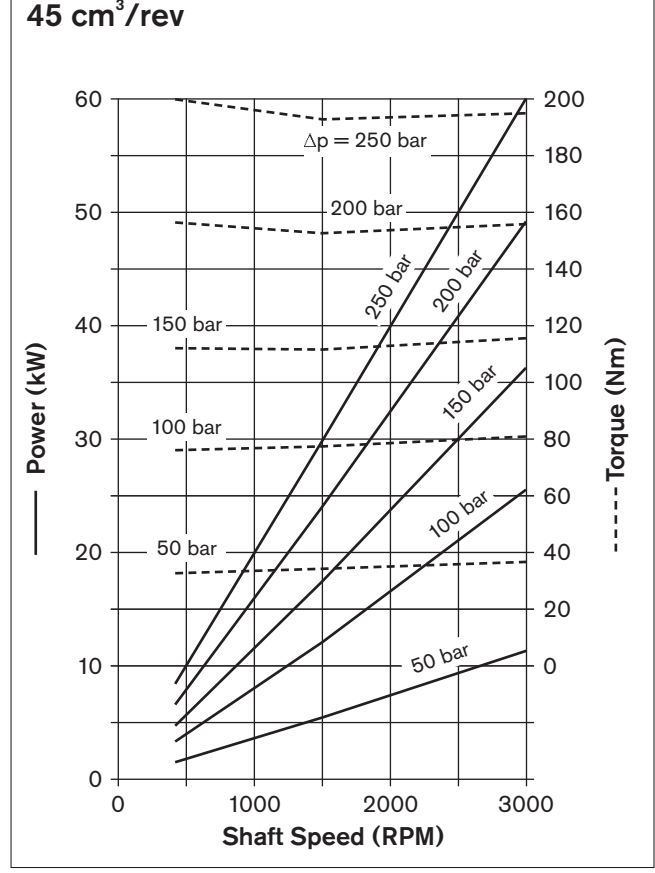
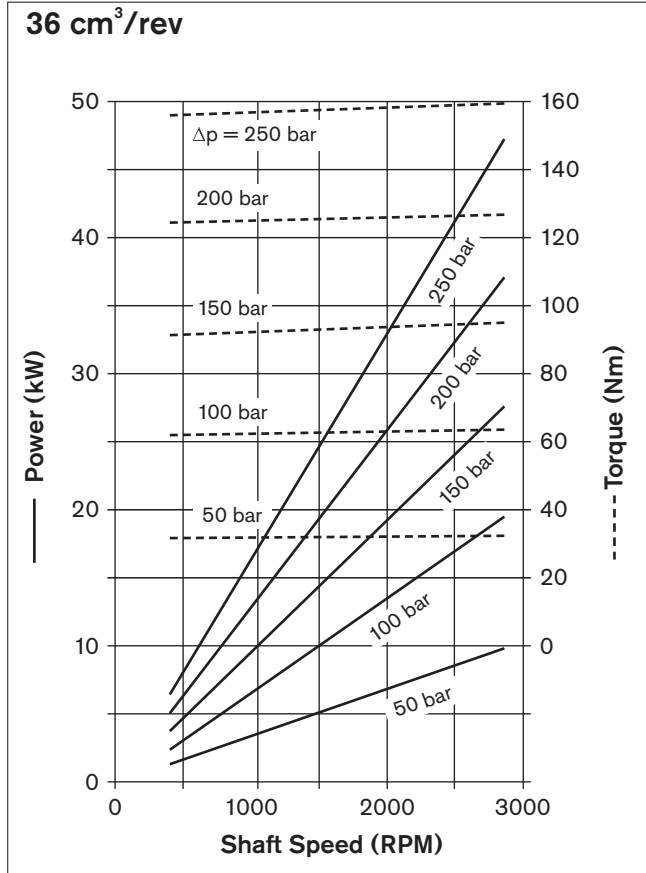



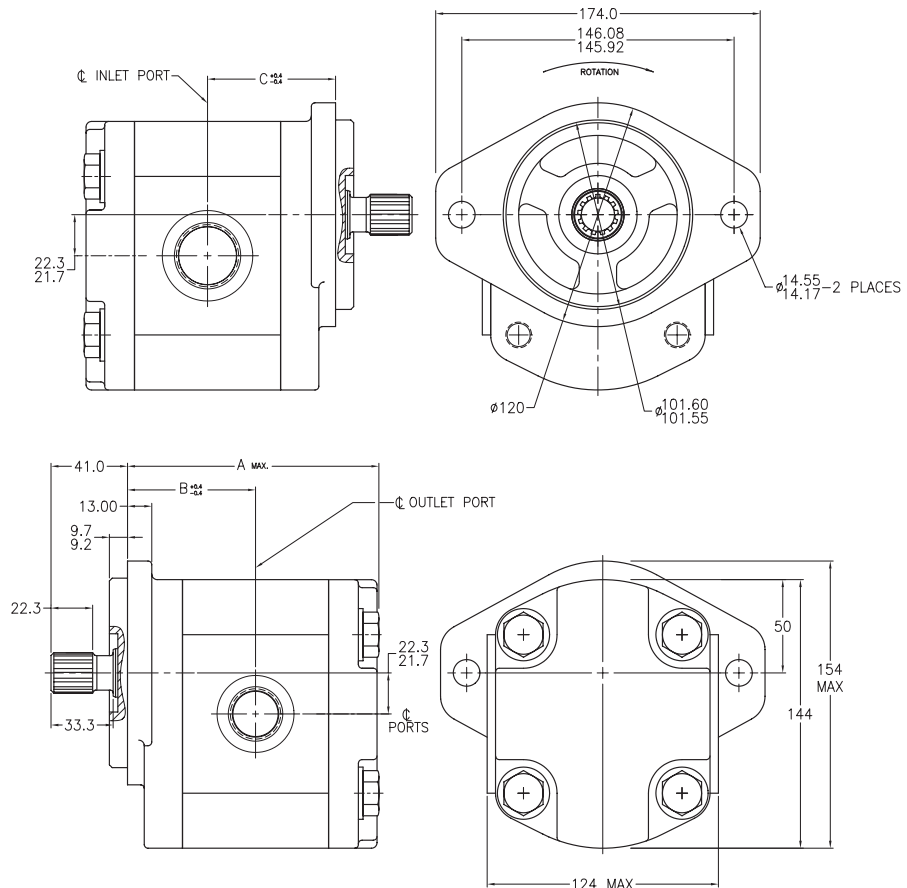

Features	Details
Shaft	13t spline
Front Cover	SAE B 2-bolt
Ports	SAE ORB
Rear Cover	Standard

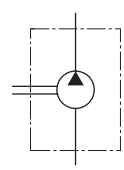

Clockwise  
As shown in drawing

Counter-Clockwise  
Inlet and outlet port changed

**Ordering code**  
AZPG - 2 2 - □ □ □ □ DC 12 MB

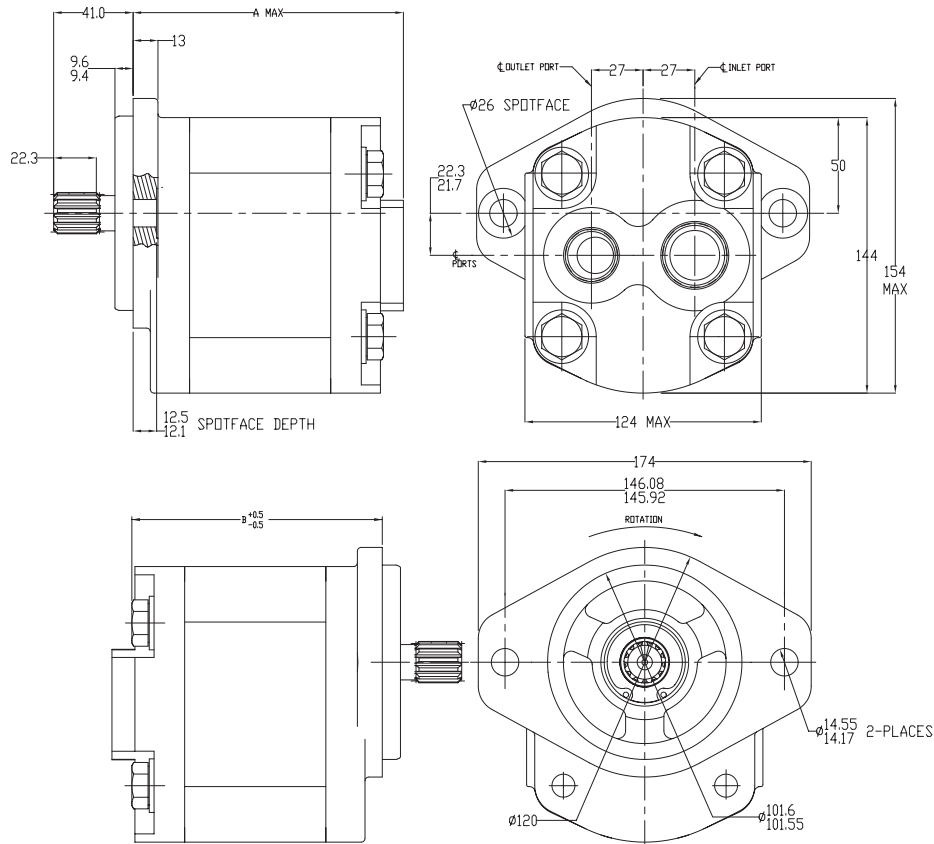

Displacement [cm <sup>3</sup> /rev]	Ordering-Number *		Max. operating pressure [bar]	Max. rotation speed [min <sup>-1</sup> ]	Dimension [mm]			Inlet Port** (SAE O-Ring BOSS)	Outlet Port** (SAE O-Ring BOSS)
	L	R			A	B	C		
32.0	9 510 490 014	9 510 490 004	250	2800	139.2	70.3	70.3	-20	-16
36.0	9 510 490 015	9 510 490 005	250	2800	142.5	72.0	72.0	-20	-16
45.0	9 510 490 017	9 510 490 007	250	2600	149.9	75.7	75.7	-24	-20
56.0	9 510 490 019	9 510 490 009	195	2300	159.0	80.2	80.2	-24	-20
63.0	9 510 490 020	9 510 490 010	170	2300	164.8	83.1	83.1	-24	-20

\* Contact factory for availability of units with no ordering number listed.  
\*\* Refer to page 70 for SAE O-Ring Boss Specifications and Dimensions.



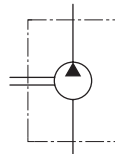

Features	Details
Shaft	13t spline
Front Cover	SAE B 2-bolt
Ports	SAE ORB
Rear Cover	Rear ports



 Clockwise  
 Inlet and outlet port changed  
  
 Counter-Clockwise  
 As shown in drawing

Ordering code  
 AZPG - 2 2 - □ □ □ □ D C 12 MA

Displacement [cm <sup>3</sup> /rev]	Ordering-Number *		Max. operating pressure [bar]	Max. rotation speed [min <sup>-1</sup> ]	Dimension [mm]		Inlet Port** (SAE O-Ring BOSS)	Outlet Port** (SAE O-Ring BOSS)
	 L	 R			A	B		
32.0	9 510 490 074	9 510 490 064	250	2800	149.4	138.7	-20	-16
36.0	9 510 490 075	9 510 490 065	250	2800	152.8	142.0	-20	-16
45.0	9 510 490 077	9 510 490 067	250	2600	160.2	149.4	-20	-16
56.0	9 510 490 079	9 510 490 069	195	2300	169.2	158.5	-20	-16
63.0	9 510 490 080	9 510 490 070	170	2300	175.1	164.3	-20	-16

\* Contact factory for availability of units with no ordering number listed.  
 \*\* Refer to page 70 for SAE O-Ring Boss Specifications and Dimensions.

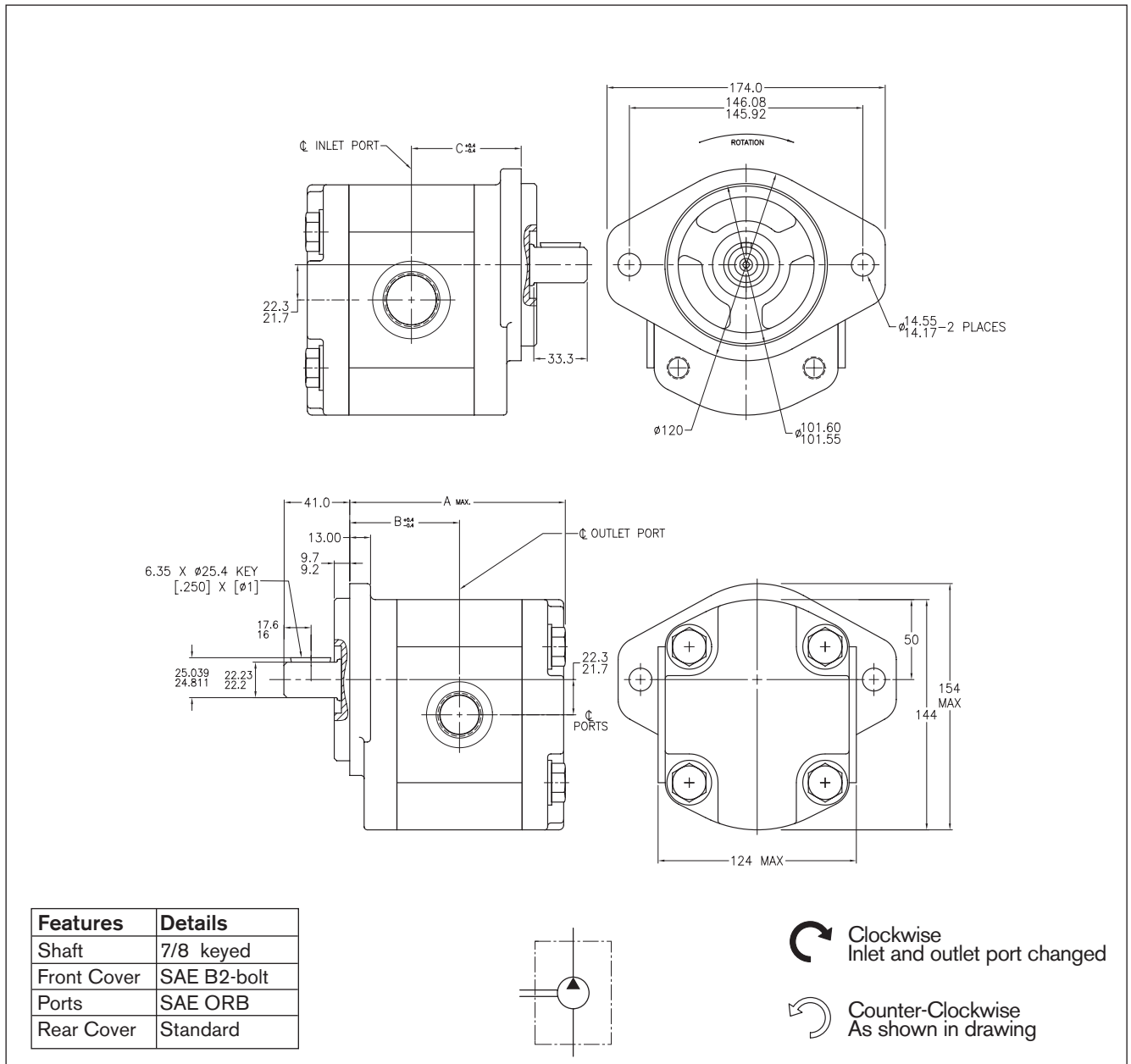

**Ordering code**

**AZPG - 2 2 - □ □ □ □ Q C 12 MB**

Displacement [cm <sup>3</sup> /rev]	Ordering-Number *		Max. operating pressure [bar]	Max. rotation speed [min <sup>-1</sup> ]	Dimension [mm]			Inlet Port** (SAE O-Ring BOSS)	Outlet Port** (SAE O-Ring BOSS)
	L	R			A	B	C		
32.0	<b>9 510 490 034</b>	<b>9 510 490 024</b>	250	2800	139.2	70.3	70.3	-20	-16
36.0	<b>9 510 490 035</b>	<b>9 510 490 025</b>	250	2800	142.5	72.0	72.0	-20	-16
45.0	<b>9 510 490 037</b>	<b>9 510 490 027</b>	250	2600	149.9	75.7	75.7	-24	-20
56.0	<b>9 510 490 039</b>	<b>9 510 490 029</b>	195	2300	159.0	80.2	80.2	-24	-20
63.0	<b>9 510 490 040</b>	<b>9 510 490 030</b>	170	2300	164.8	83.1	83.1	-24	-20

\* Contact factory for availability of units with no ordering number listed.

\*\* Refer to page 70 for SAE O-Ring Boss Specifications and Dimensions.

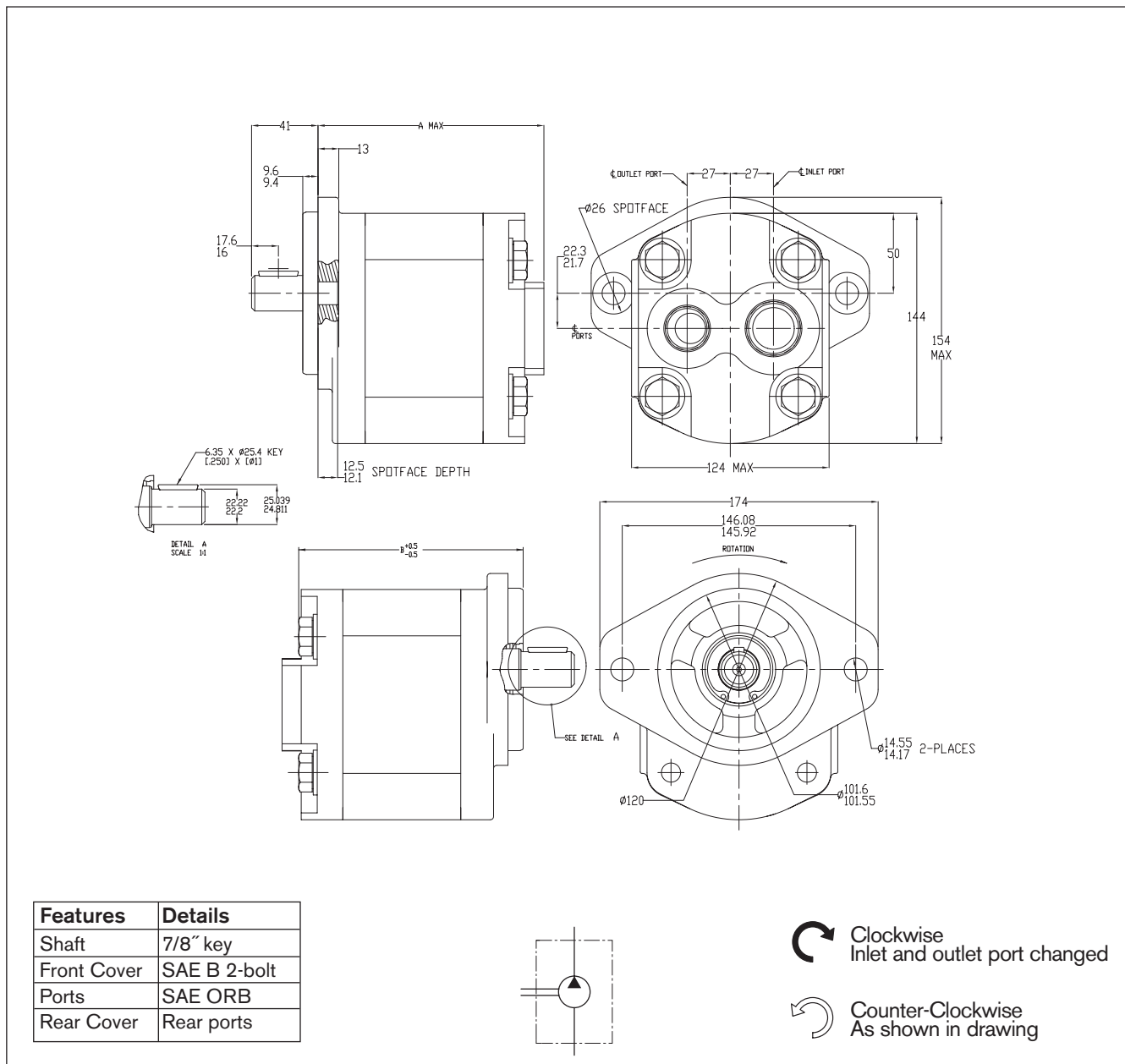

**Ordering code**

AZPG - 2 2 - □□□□ Q C 12 MA

Displacement [cm <sup>3</sup> /rev]	Ordering-Number *		Max. operating pressure [bar]	Max. rotation speed [min <sup>-1</sup> ]	Dimension [mm]		Inlet Port** (SAE O-Ring BOSS)	Outlet Port** (SAE O-Ring BOSS)
	L	R			A	B		
32.0	9 510 490 114	9 510 490 104	250	2800	149.4	138.7	-20	-16
36.0	9 510 490 115	9 510 490 105	250	2800	152.8	142.0	-20	-16
45.0	9 510 490 117	9 510 490 107	250	2600	160.2	149.4	-20	-16
56.0	9 510 490 119	9 510 490 109	195	2300	169.2	158.5	-20	-16
63.0	9 510 490 120	9 510 490 110	170	2300	175.1	164.3	-20	-16

\* Contact factory for availability of units with no ordering number listed.  
 \*\* Refer to page 70 for SAE O-Ring Boss Specifications and Dimensions.

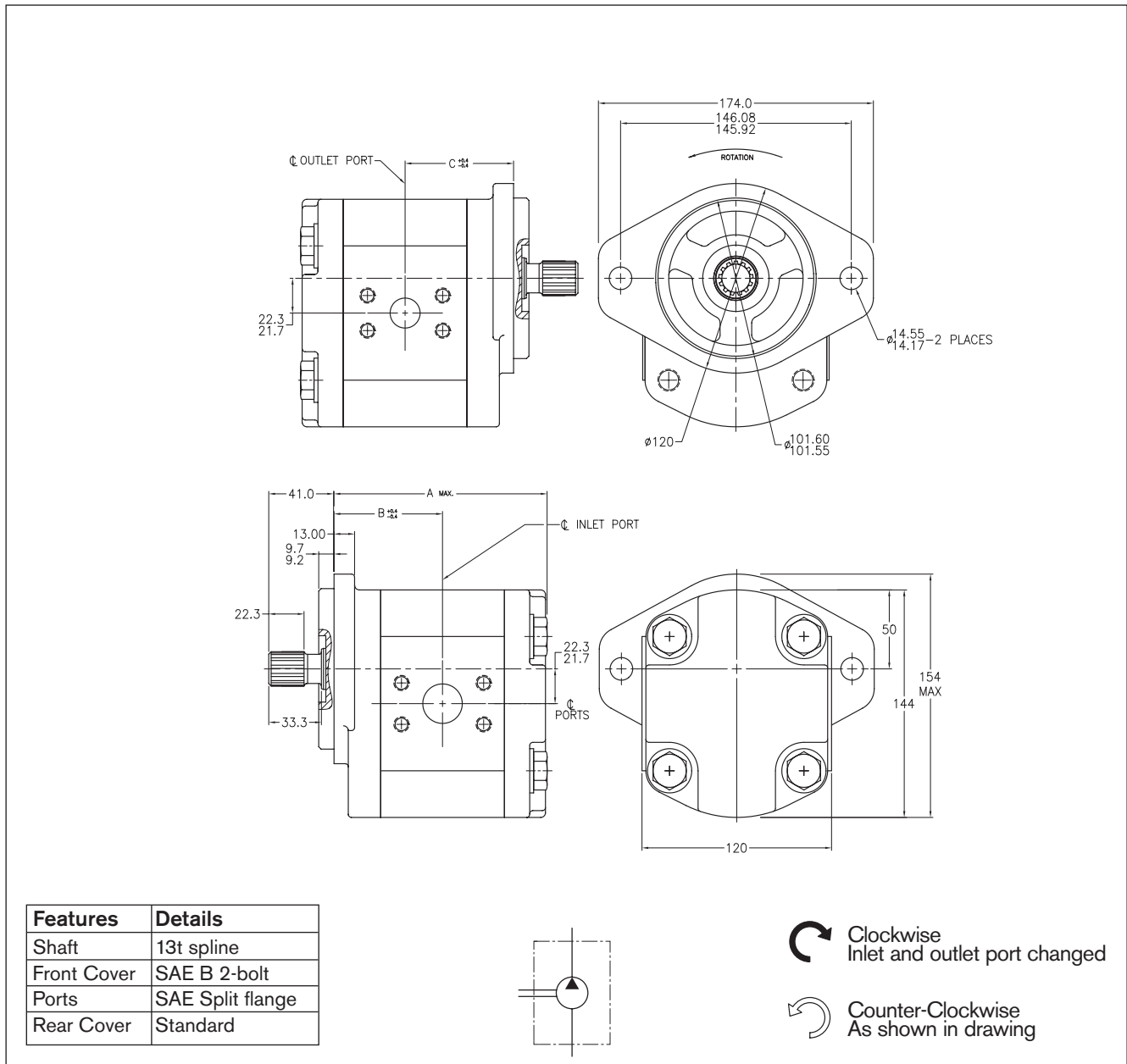

**Ordering code**

**AZPG - 2 2 - □ □ □ □ D C 40 MB**

Displacement [cm <sup>3</sup> /rev]	Ordering-Number *		Max. operating pressure [bar]	Max. rotation speed [min <sup>-1</sup> ]	Dimension [mm]			Port Size Per SAE J 518	
	L	R			A	B	C	Inlet Port**	Outlet Port**
32.0	<b>9 510 490 054</b>	<b>9 510 490 044</b>	250	2800	139.2	70.3	70.3	-16	-12
36.0	<b>9 510 490 055</b>	<b>9 510 490 045</b>	250	2800	142.5	72.0	72.0	-16	-12
45.0	<b>9 510 490 057</b>	<b>9 510 490 047</b>	250	2600	149.9	75.7	75.7	-20	-16
56.0	<b>9 510 490 059</b>	<b>9 510 490 049</b>	195	2300	159.0	80.2	80.2	-24	-20
63.0	<b>9 510 490 060</b>	<b>9 510 490 050</b>	170	2300	164.8	83.1	83.1	-24	-20

\* Contact factory for availability of units with no ordering number listed.

\*\* Refer to page 70 for SAE Split flange porting Specifications and Dimensions.

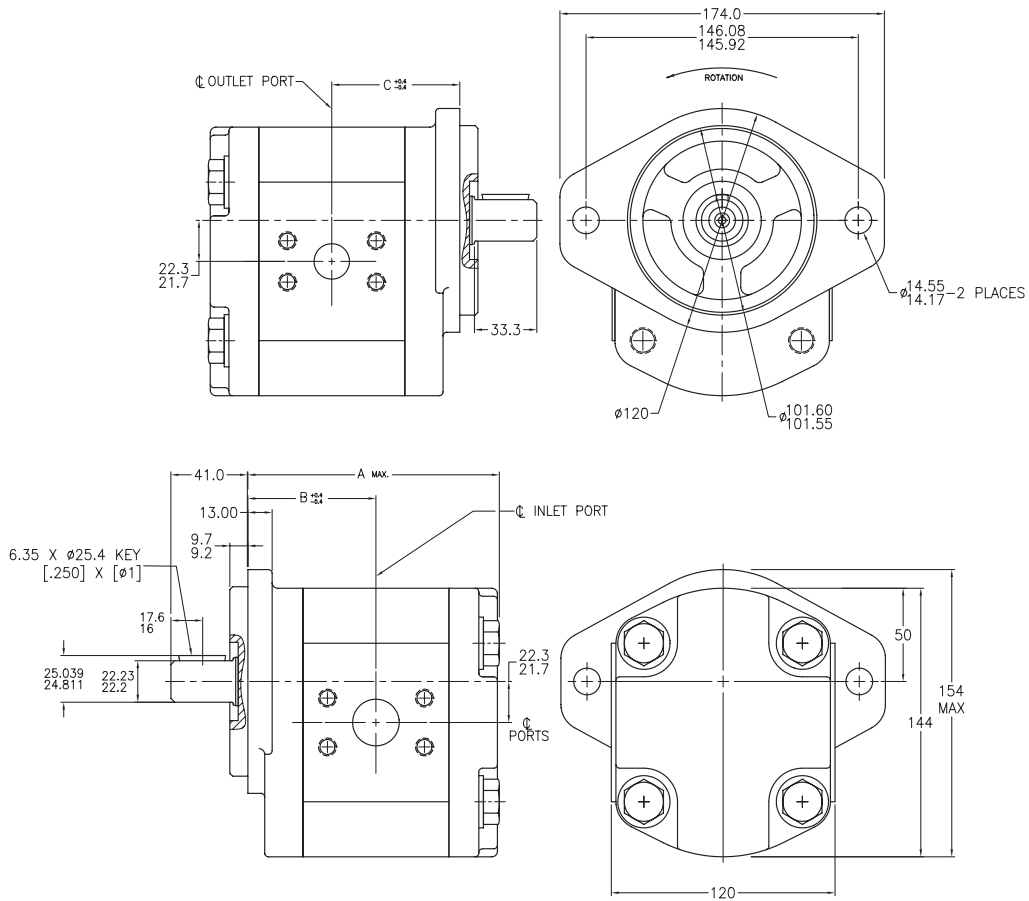

Features	Details
Shaft	7/8" keyed
Front Cover	SAE B 2-bolt
Ports	SAE Split flange
Rear Cover	Standard

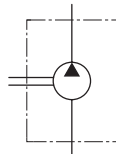

Clockwise  
Inlet and outlet port changed

Counter-Clockwise  
As shown in drawing

**Ordering code**

**AZPG - 2 2 - □□□□ Q C 40 MB**

Displacement [cm <sup>3</sup> /rev]	Ordering-Number *		Max. operating pressure [bar]	Max. rotation speed [min <sup>-1</sup> ]	Dimension [mm]			Port Size Per SAE J 518	
	L	R			A	B	C	Inlet Port**	Outlet Port**
32.0	<b>9 510 490 094</b>	<b>9 510 490 084</b>	250	2800	139.2	70.3	70.3	-16	-12
36.0	<b>9 510 490 095</b>	<b>9 510 490 085</b>	250	2800	142.5	72.0	72.0	-16	-12
45.0	<b>9 510 490 097</b>	<b>9 510 490 087</b>	250	2600	149.9	75.7	75.7	-20	-16
56.0	<b>9 510 490 099</b>	<b>9 510 490 089</b>	195	2300	159.0	80.2	80.2	-24	-20
63.0	<b>9 510 490 100</b>	<b>9 510 490 090</b>	170	2300	164.8	83.1	83.1	-24	-20

















\* Contact factory for availability of units with no ordering number listed.  
 \*\* Refer to page 70 for SAE Split flange porting Specifications and Dimensions.

**Notes**

---

# Ordering code

## External Gear Pumps – Multiple Pumps

<b>AZ</b>	<b>P</b>	<b>GGFF</b>	-	<input type="checkbox"/>	<input type="checkbox"/>	-	<b>032 / 022 / 016 / 005</b>	<b>R</b>	<b>R</b>	<b>R</b>	<b>12</b>	<b>12</b>	<b>12</b>	<b>12</b>	<b>M</b>	<b>B</b>			
<b>Function</b>																			
P = Pump																			
<b>Model **</b>																			
F = 4.0 ... 28.0 cm <sup>3</sup> /rev																			
N = 20.0 ... 36.0 cm <sup>3</sup> /rev																			
G = 32.0 ... 63.0 cm <sup>3</sup> /rev																			
<b>Series</b>																			
1x = Standard bearing																			
2x = Reinforced bearing																			
<b>Size</b>																			
Based on available sizes per series																			
<b>Direction of rotation</b>																			
Right = R																			
Left = L																			
															<b>Rear cover</b> refers on the last pumps part				
															Model F Standard = <b>B</b>				
															Model N Standard = <b>B</b>				
															Model G Standard = <b>B</b>				
															<b>Seals</b>				
															NBR = <b>M</b>				
															NBR, Shaft Seal in FPM = <b>K</b>				
<b>Drive shafts</b>							<b>Front cover</b>					<b>Port connections</b>							
<b>Model F:</b>																			
<b>Q</b>	Cylindrical (Straight Way) SAE A 5/8"		<b>R</b>				<b>C</b>	SAE B 2-bolt flange Pilot Ø 101.6 mm		<b>12</b>		Thread (UN-2B) SAE O-Ring BOSS							
<b>P</b>	Spline Shaft SAE 11T		<b>R</b>	<b>C</b>			<b>R</b>	SAE A 2-bolt flange Ø 82.55 mm											
<b>R</b>	Multiple spline shaft SAE A 5/8" 9T		<b>R</b>	<b>C</b>															
<b>Model N:</b>																			
<b>P</b>	Spline Shaft SAE 11T		<b>R</b>	<b>C</b>			<b>R</b>	SAE A 2-bolt flange Ø 82.55 mm		<b>12</b>		Thread (UN-2B) SAE O-Ring BOSS							
<b>D</b>	Multiple spline shaft SAE B 13T				<b>C</b>			<b>C</b>	SAE B 2-bolt flange Pilot Ø 101.6 mm										
<b>Q</b>	SAE 3/4" Keyed, Short		<b>R</b>	<b>C</b>															
<b>Model G:</b>																			
<b>D</b>	Multiple spline shaft SAE B 13T				<b>C</b>			<b>C</b>	SAE B 2-bolt flange Pilot Ø 101.6 mm		<b>12</b>		Thread (UN-2B) SAE O-Ring BOSS						
<b>Q</b>	Cylindrical (Straight Key) SAE B 7/8"				<b>C</b>								<b>40</b>		Split Flange SAE Code 61 UNC bolts				

\* Contact factory for availability of units with no ordering number listed  
 \*\* Refer to page 18 for SAE O-Ring Boss Specifications and dimensions



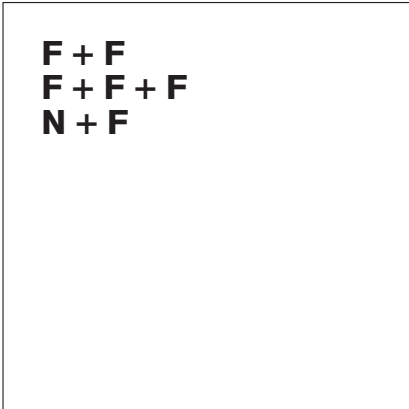

### N Series Pump Product Index

(Reference page 43 for ordering code designators)



Page Number	Ordering code	Shaft Type	Mounting Flange	Ports	Port Orientation
82	AZPFF-XX-XXX/XXXXRR1212MB	R	R	12	side
83	AZPFF-XX-XXX/XXXXQR1212MB	Q	R	12	side
84	AZPFF-XX-XXX/XXXXPR1212MB	P	R	12	side
85	AZPFF-XX-XXX/XXXXCB2020MB	C	B	20	side
86	AZPFF-XX-XXX/XXXXFB2020MB	F	B	20	side
87	AZPFF-XX-XXX/XXXXNM2020MB	N	M	20	side
88	AZPFF-XX-XXX/XXXXRR2020MB	R	R	20	side
89	AZPFF-XX-XXX/XXXXSA2020MB	S	A	20	side
90	AZPFFF-XX-XXX/XXX/XXXXFB202020MB	F	B	20	side
91	AZPNF-XX-XXX/XXXXDC2020KB	D	C	20	side

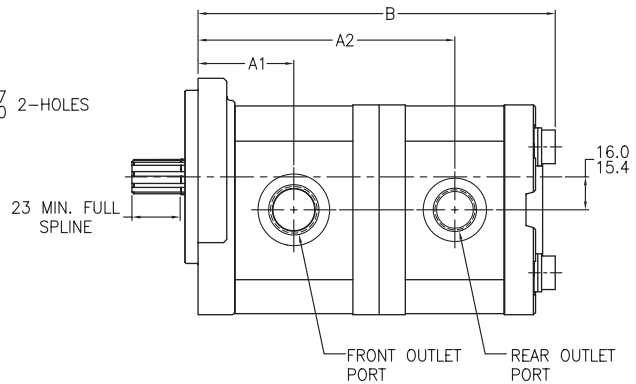
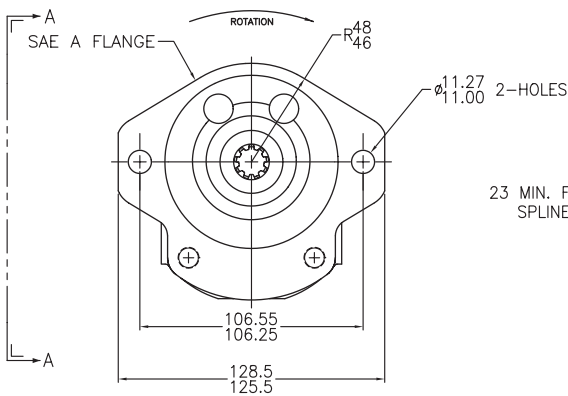
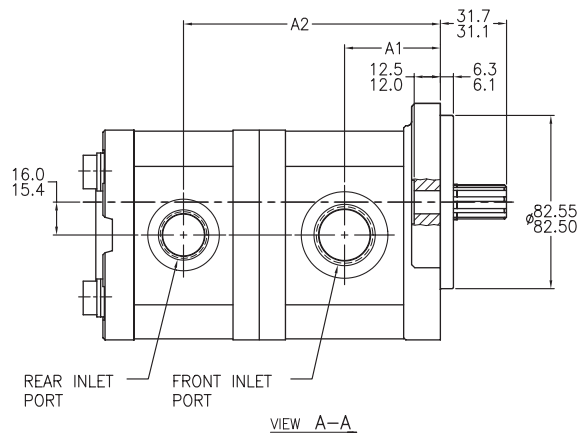
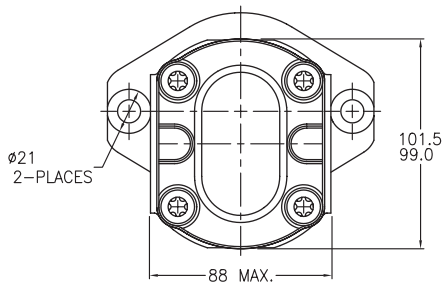

Features	Details
Shaft	9t spline
Front Cover	SAE A 2-bolt
Ports	SAE ORB
Rear Cover	Standard

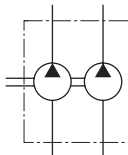

Clockwise  
As shown in drawing

Counter-Clockwise  
Inlet and outlet port changed

Ordering code  
AZPFF - X X - □□□ - □□□□ R R 12 12 MB

Displacement [cm <sup>3</sup> /rev]	Ordering-Number *		Max. operating pressure [bar]	Max. rotation speed [min <sup>-1</sup> ]	Dimension [mm]			Inlet Port** (SAE O-Ring BOSS)	Outlet Port** (SAE O-Ring BOSS)
	L	R			A1	A2	B		
008 / 008	*	<b>9 510 290 034</b>	250	3000	43.2	119.5	166.2	-12 / -12	-8 / -8
011 / 005	*	<b>9 510 290 142</b>	210	3000	45.7	122.4	170.9	-12 / -10	-10 / -8
014 / 005	*	<b>9 510 290 143</b>	210	3000	48.2	127.4	175.9	-12 / -10	-10 / -8
014 / 008	*	<b>9 510 290 144</b>	210	3000	48.2	129.0	176.2	-12 / -12	-10 / -10

\* Contact factory for availability of units with no ordering number listed.  
\*\* Refer to page 19 for SAE O-Ring Boss Specifications and Dimensions.

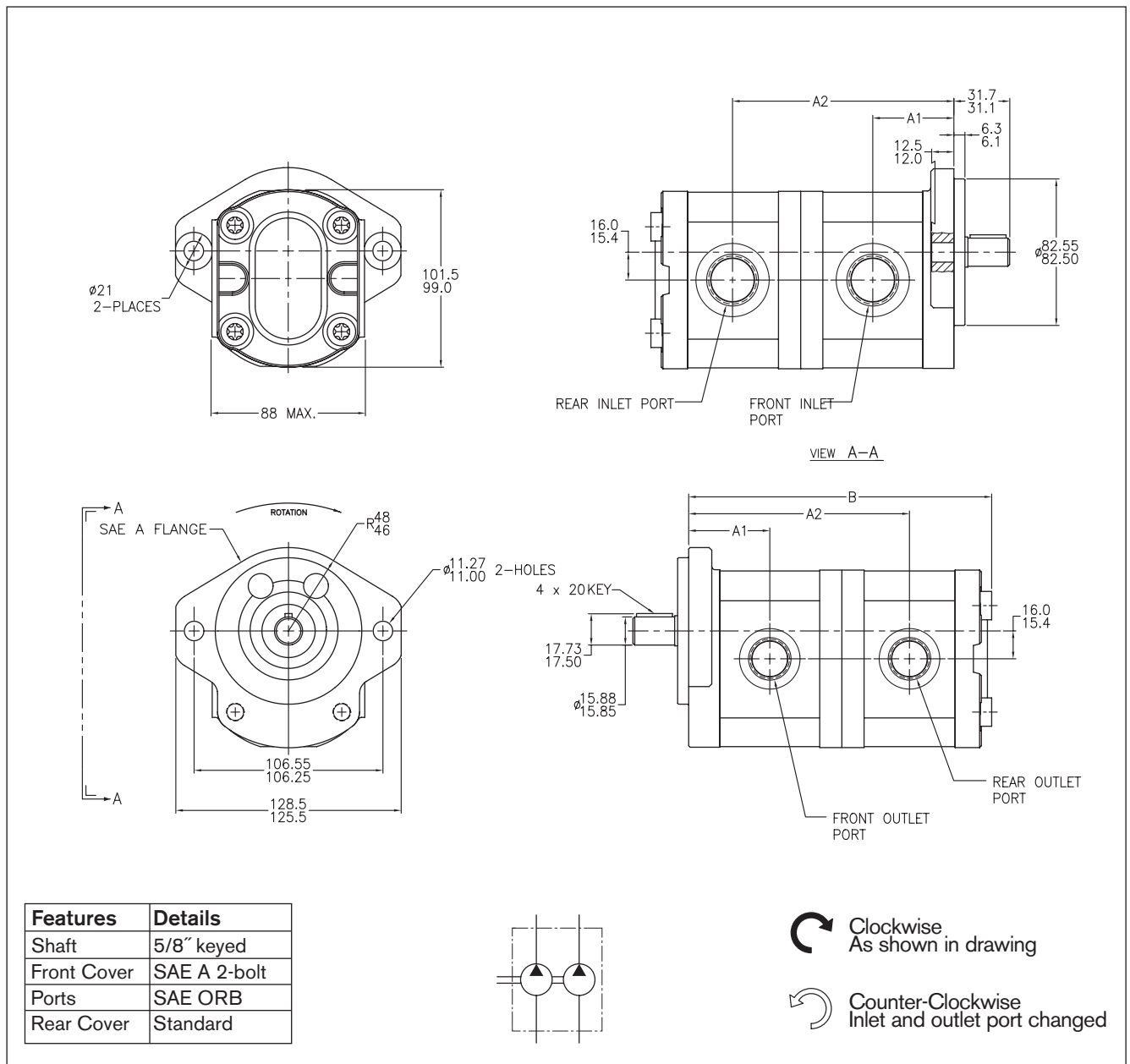

**Ordering code**

**AZPFF - X X - □□□ / □□□□ Q R 12 12 MB**

Displacement [cm <sup>3</sup> /rev]	Ordering-Number *		Max. operating pressure [bar]	Max. rotation speed [min <sup>-1</sup> ]	Dimension [mm]			Inlet Port** (SAE O-Ring BOSS)	Outlet Port** (SAE O-Ring BOSS)
	L	R			A1	A2	B		
008 / 004	*	<b>9 510 290 138</b>	210	3000	43.2	155.0	161.5	-12 / -10	-10 / -8
008 / 008	*	<b>9 510 290 137</b>	210	3000	43.2	155.0	166.2	-12 / -12	-10 / -10
011 / 004	*	<b>9 510 290 139</b>	210	3000	45.7	121.3	164.6	-12 / -10	-10 / -8
011 / 005	*	<b>9 510 290 140</b>	210	3000	45.7	122.5	170.9	-12 / -10	-10 / -8
011 / 008	*	<b>9 510 290 141</b>	210	3000	45.7	124.6	171.2	-12 / -12	-10 / -10
014 / 005	*	<b>9 510 290 052</b>	210	3000	48.2	127.4	175.9	-12 / -10	-10 / -8

\* Contact factory for availability of units with no ordering number listed.

\*\* Refer to page 19 for SAE O-Ring Boss Specifications and Dimensions.

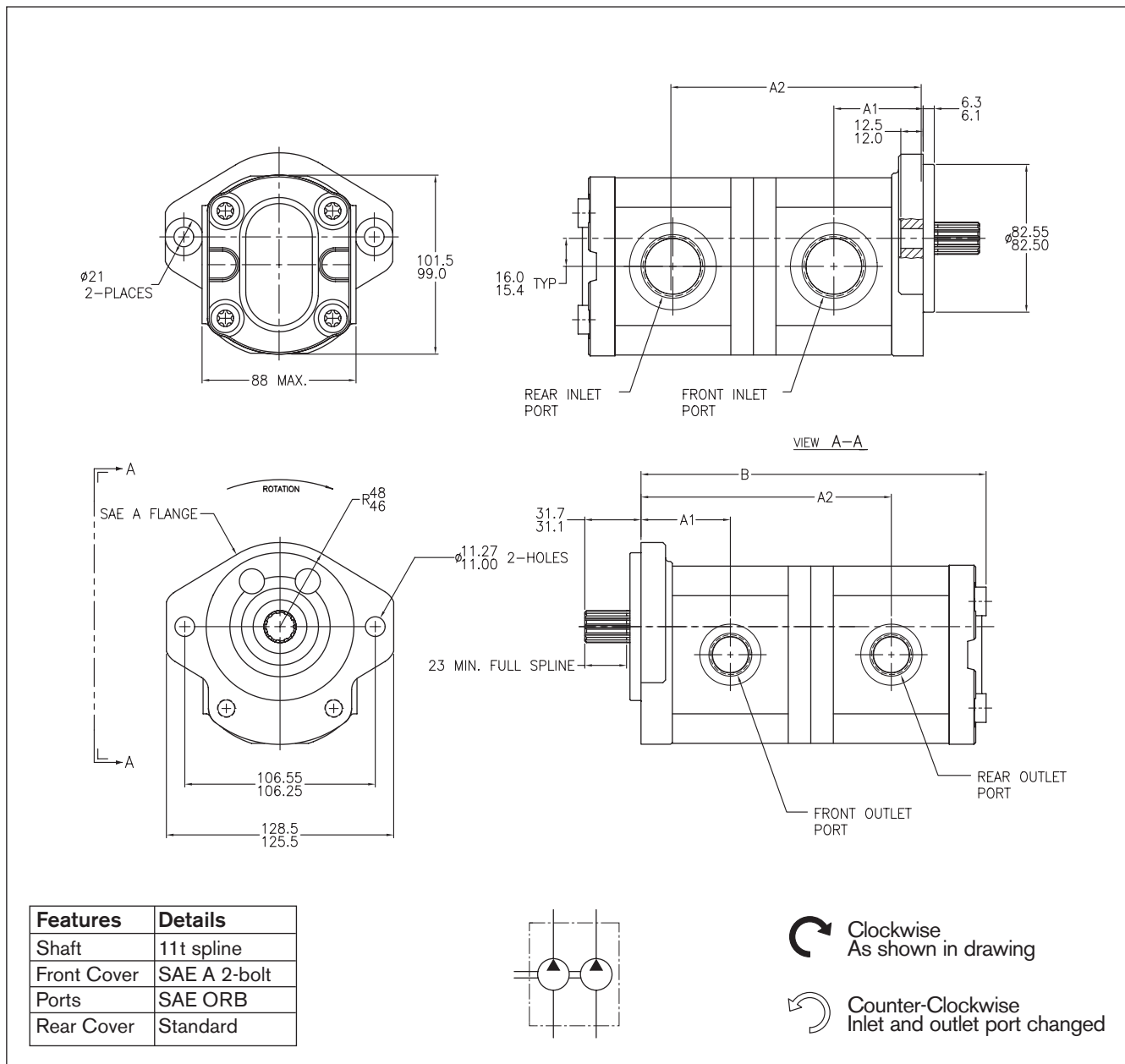

**Ordering code**

**AZPFF - X X - □□□ - □□□□ P R 12 12 MB**

Displacement [cm <sup>3</sup> /rev]	Ordering-Number *		Max. operating pressure [bar]	Max. rotation speed [min <sup>-1</sup> ]	Dimension [mm]			Inlet Port** (SAE O-Ring BOSS)	Outlet Port** (SAE O-Ring BOSS)
	L	R			A1	A2	B		
016 / 016	*	<b>9 510 290 108</b>	210	3000	49.9	139.6	193.0	-16 / -16	-10 / -10

\* Contact factory for availability of units with no ordering number listed.  
 \*\* Refer to page 19 for SAE O-Ring Boss Specifications and Dimensions.

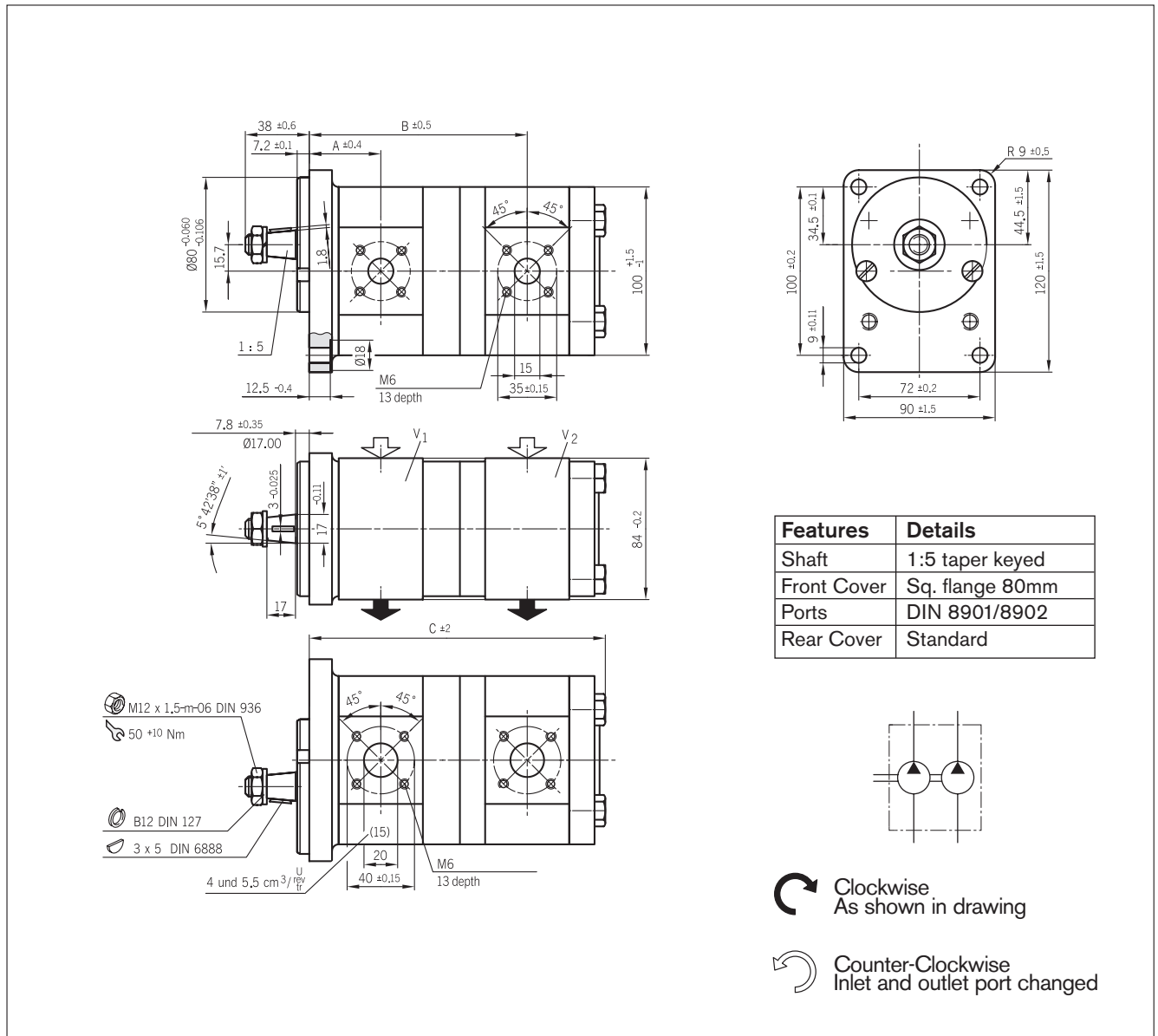

**Ordering code**

**AZPFF - X X - □□□ / □□□□ C B 20 20 MB**  
**+ AZPFF - X X - □□□ / □□□□ C B 20 20 MB - S0012**

Displacement [cm <sup>3</sup> /rev]	Ordering-Number *		Max. operating pressure [bar]	Max. rotation speed [min <sup>-1</sup> ]	Dimension [mm]		
	L	R			A	B	C
014 / 008	<b>0 510 565 364</b>	<b>0 510 565 012</b>	280	3000	47.5	141.5	188.1
014 / 011	<b>0 510 565 353</b>	<b>0 510 565 033</b>	280	3000	47.5	145.3	193.1
014 / 014		<b>0 510 565 037</b>	280	3000	47.5	145.8	198.1
019 / 05.5		<b>0 510 665 067</b>	230/280	3000	47.5	147.8	192.4
019 / 008	<b>0 510 665 325</b>	<b>0 510 665 024</b>	230/280	3000	47.5	149.9	196.5
019 / 011	<b>0 510 665 326</b>		230/280	3000	47.5	153.9	201.5
019 / 016	<b>0 510 665 327</b>	<b>0 510 665 053</b>	230	3000	47.5	154.2	209.9
019 / 019	<b>0 510 665 400</b>	<b>0 510 665 025</b>	230/190	3000	47.5	154.2	214.9
22.5 / 008		<b>0 510 765 023+</b>	230/280	3000	61.0	167.2	213.9
22.5 / 011	<b>0 510 765 320+</b>		230/280	3000	61.0	171.5	218.2
22.5 / 016	<b>0 510 465 340+</b>				61.0	171.6	227.3
22.5 / 22.5		<b>0 510 765 012+</b>	230/160	3000	61.0	185.2	249.7

\* Contact factory for availability of units with no ordering number listed.

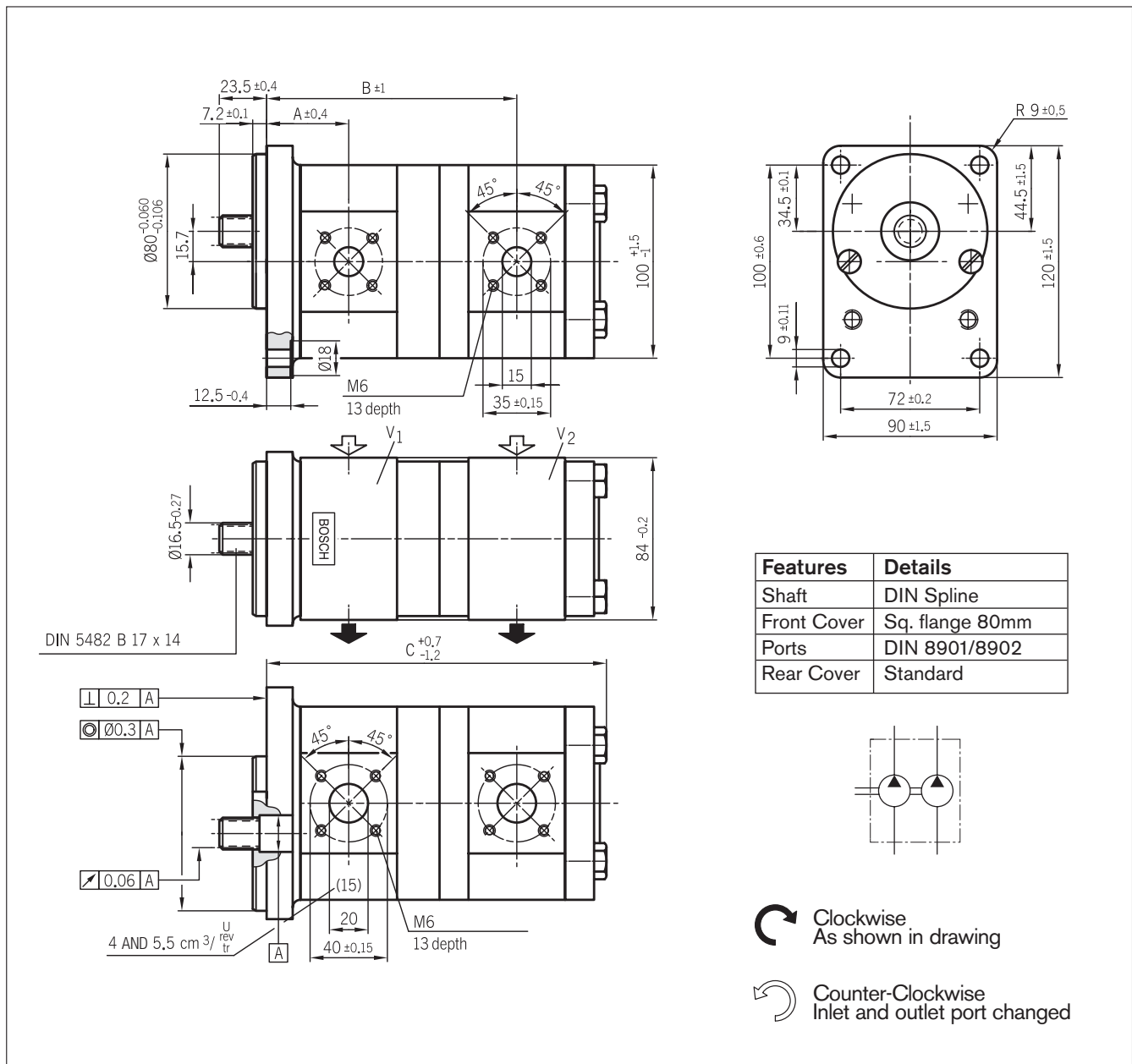

**Ordering code**

**AZPFF - X X - □□□ / □□□ F B 20 20 MB**

Displacement [cm³/rev]	Ordering-Number *		Max. operating pressure [bar]	Max. rotation speed [min⁻¹]	Dimension [mm]		
	L	R			A	B	C
019 / 011	<b>0 510 665 375</b>		230/280	3000	47.5	153.7	201.5
019 / 019	<b>0 510 665 420</b>	<b>0 510 665 097</b>	230/190	3000	47.5	154.2	214.9
022 / 05.5	<b>0 510 765 317</b>	<b>0 510 665 022</b>	210/280	2500	61.1	165.2	209.8
022 / 008	<b>0 510 765 331</b>		210/280	2500	61.1	167.3	213.9

\* Contact factory for availability of units with no ordering number listed.

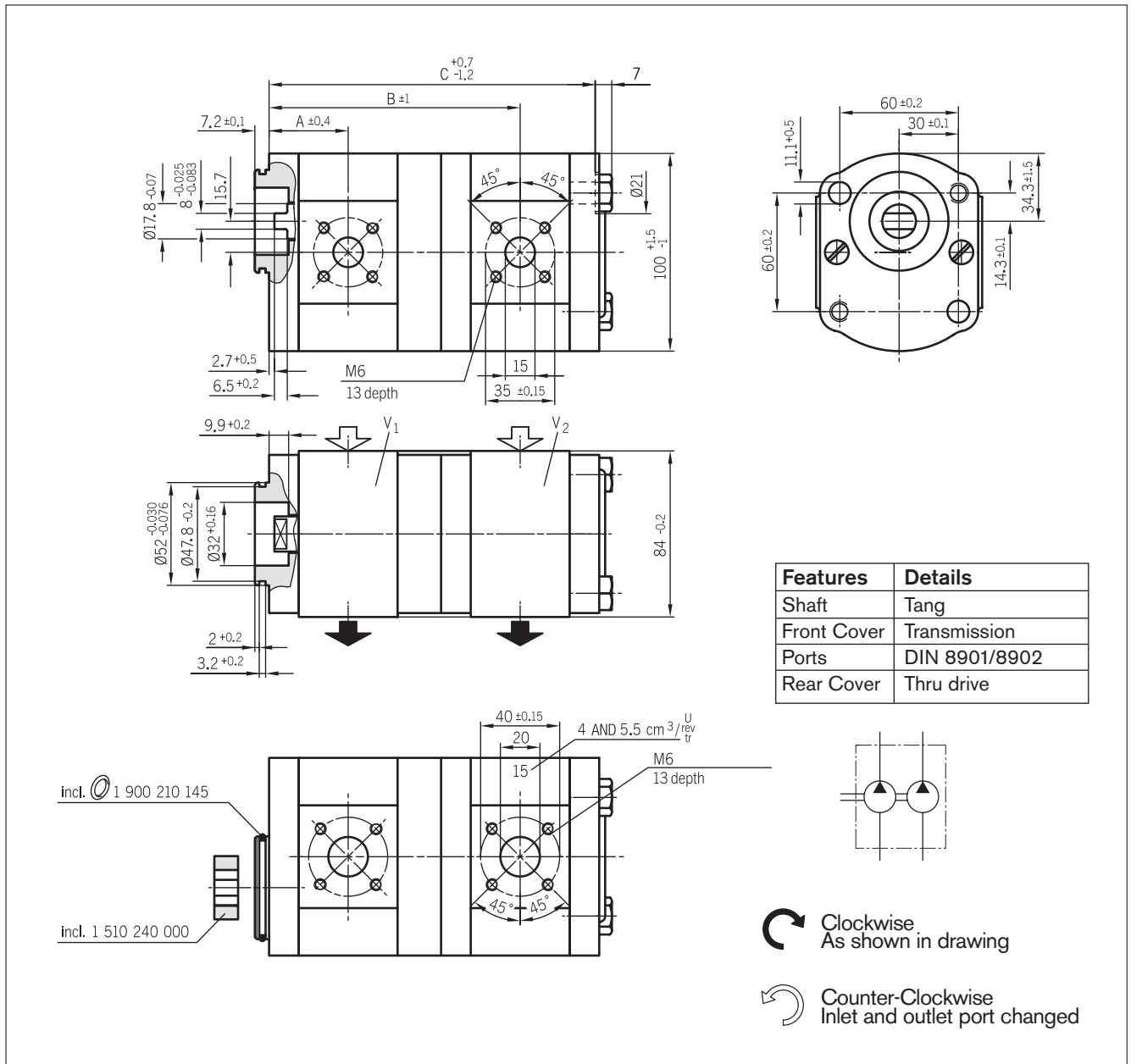

**Ordering code**

**AZPFF - X X - □□□ / □□□ N M 20 20 MB**

Displacement [cm <sup>3</sup> /rev]	Ordering-Number *		Max. operating pressure [bar]	Max. rotation speed [min <sup>-1</sup> ]	Dimension [mm]		
	L	R			A	B	C
05.5 / 004	<b>0 510 365 314</b>	<b>0 510 365 010</b>	280	4000	38.6	121.6	157.9
008 / 004		<b>0 510 465 012</b>	280	4000	40.7	125.7	162.0
008 / 05.5	<b>0 510 465 346</b>	<b>0 510 465 008</b>	280	4000	40.7	126.9	164.5
011 / 004	<b>0 510 565 329</b>	<b>0 510 565 015</b>	280	3500	44.5	130.7	167.0
011 / 05.5		<b>0 510 565 016</b>	280	3500	44.5	131.9	169.5
011 / 008	<b>0 510 565 379</b>	<b>0 510 565 078</b>	280	3500	44.5	134.0	173.6
016 / 016	<b>0 510 565 339</b>	<b>0 510 665 030</b>	280/230	3000	45.0	146.7	195.4
022 / 008	<b>0 510 765 312</b>		210/280	3000	52.6	152.8	194.0

\* Contact factory for availability of units with no ordering number listed.

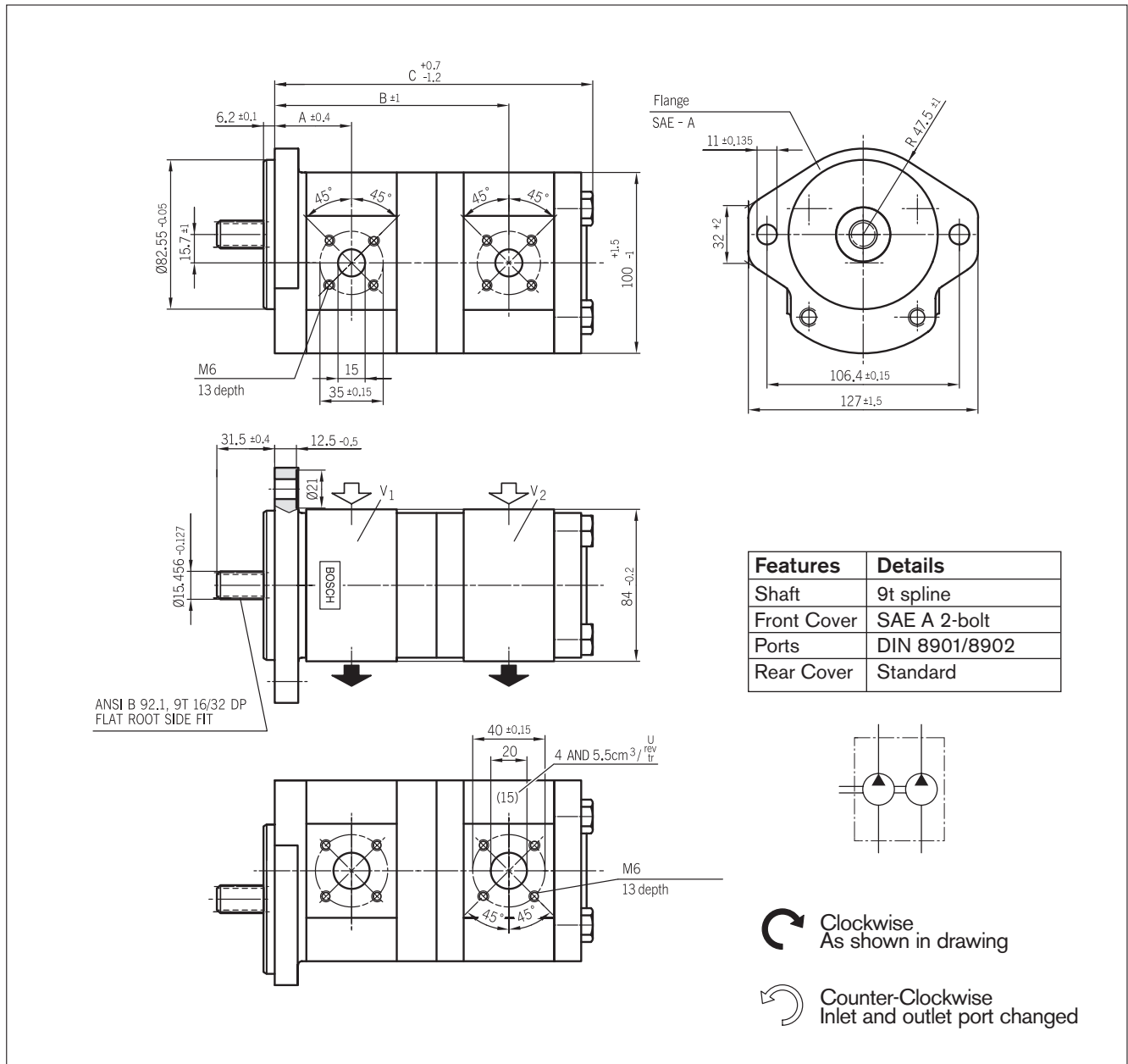

**Ordering code**

**AZPFF - X X - □□□ / □□□□ R R 20 20 MB**

Displacement [cm <sup>3</sup> /rev]	Ordering-Number *		Max. operating pressure [bar]	Max. rotation speed [min <sup>-1</sup> ]	Dimension [mm]		
	L	R			A	B	C
011 / 004		<b>0 510 565 022</b>	280	3500	47.0	133.2	176.5
011 / 05.5		<b>0 510 565 023</b>	280	3500	47.0	134.4	179.0
014 / 011	<b>0 510 565 346</b>		280	3000	47.0	147.8	191.1

\* Contact factory for availability of units with no ordering number listed.



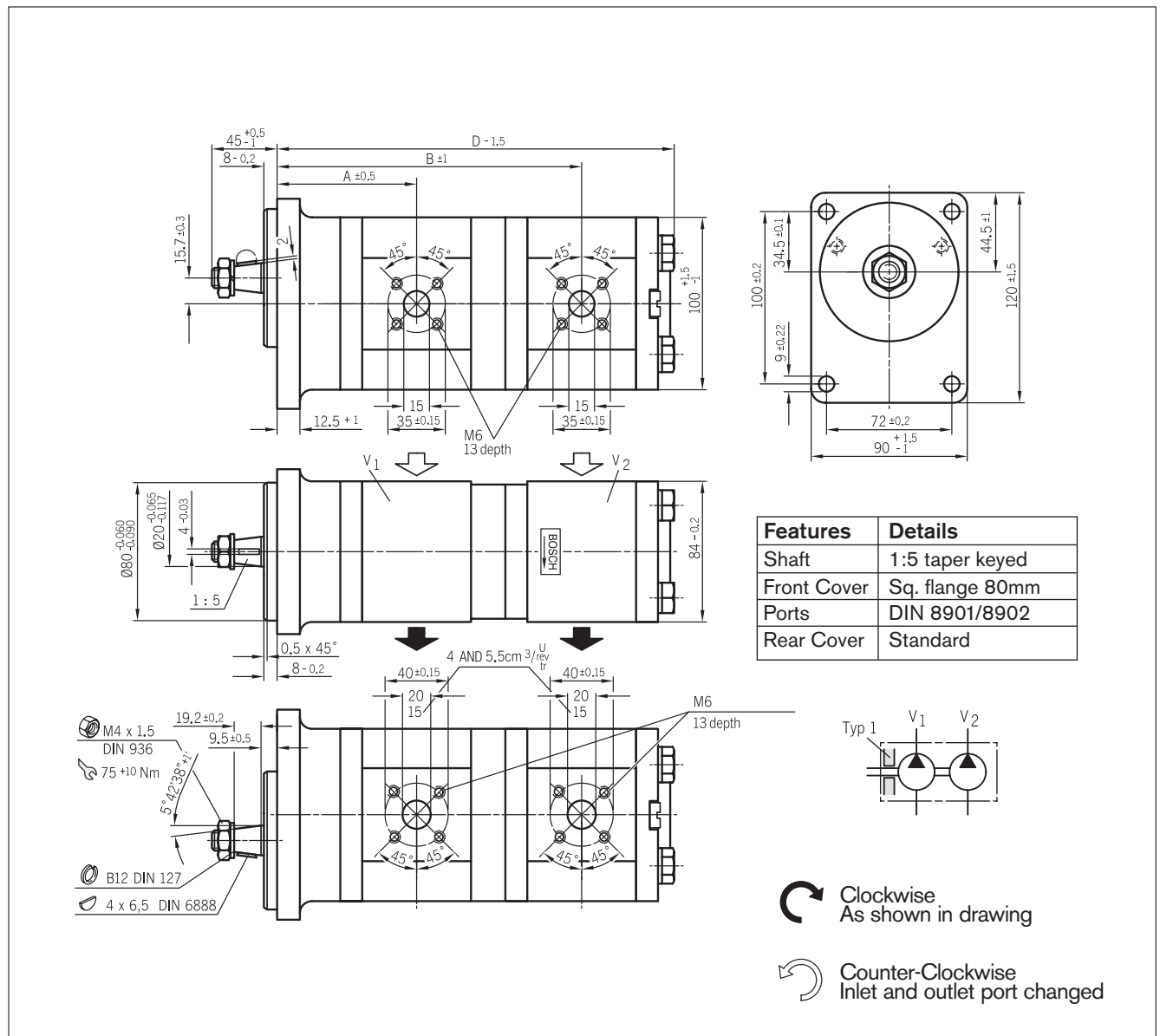

**Ordering code**

**AZPFF - X X - □□□ / □□□□ S A 20 20 MB**

Displacement [cm³/rev]	Ordering-Number *		Max. operating pressure [bar]	Max. rotation speed [min <sup>-1</sup> ]	Dimension [mm]		
	L	R			A	B	D
004 / 004	<b>0 510 255 300</b>		280	4000	71.3	153.0	197.0
05.5 / 004	<b>0 510 355 301</b>		280	4000	72.6	155.5	199.5
008 / 05.5	<b>0 510 455 300</b>	<b>0 510 455 001</b>	280	4000	74.6	160.8	205.1
008 / 008	<b>0 510 455 301</b>	<b>0 510 455 002</b>	280	4000	74.6	163.0	210.2
011 / 05.5	<b>0 510 555 300</b>	<b>0 510 555 001</b>	280	3500	79.0	165.8	211.1
011 / 008	<b>0 510 555 301</b>	<b>0 510 555 002</b>	280	3500	79.0	168.0	215.2
011 / 011	<b>0 510 555 302</b>	<b>0 510 555 003</b>	280	3500	79.0	172.3	220.2
016 / 004	<b>0 510 655 300</b>	<b>0 510 655 001</b>	280	3000	79.0	173.0	217.0
016 / 05.5	<b>0 510 655 301</b>	<b>0 510 655 002</b>	280	3000	79.0	174.2	219.5
016 / 008	<b>0 510 655 302</b>	<b>0 510 655 003</b>	280	3000	79.0	176.3	223.6
016 / 011	<b>0 510 655 303</b>	<b>0 510 655 004</b>	280	3000	79.0	180.7	228.6
016 / 016	<b>0 510 655 304</b>	<b>0 510 655 005</b>	280	3000	79.0	180.7	237.0

\* Contact factory for availability of units with no ordering number listed.

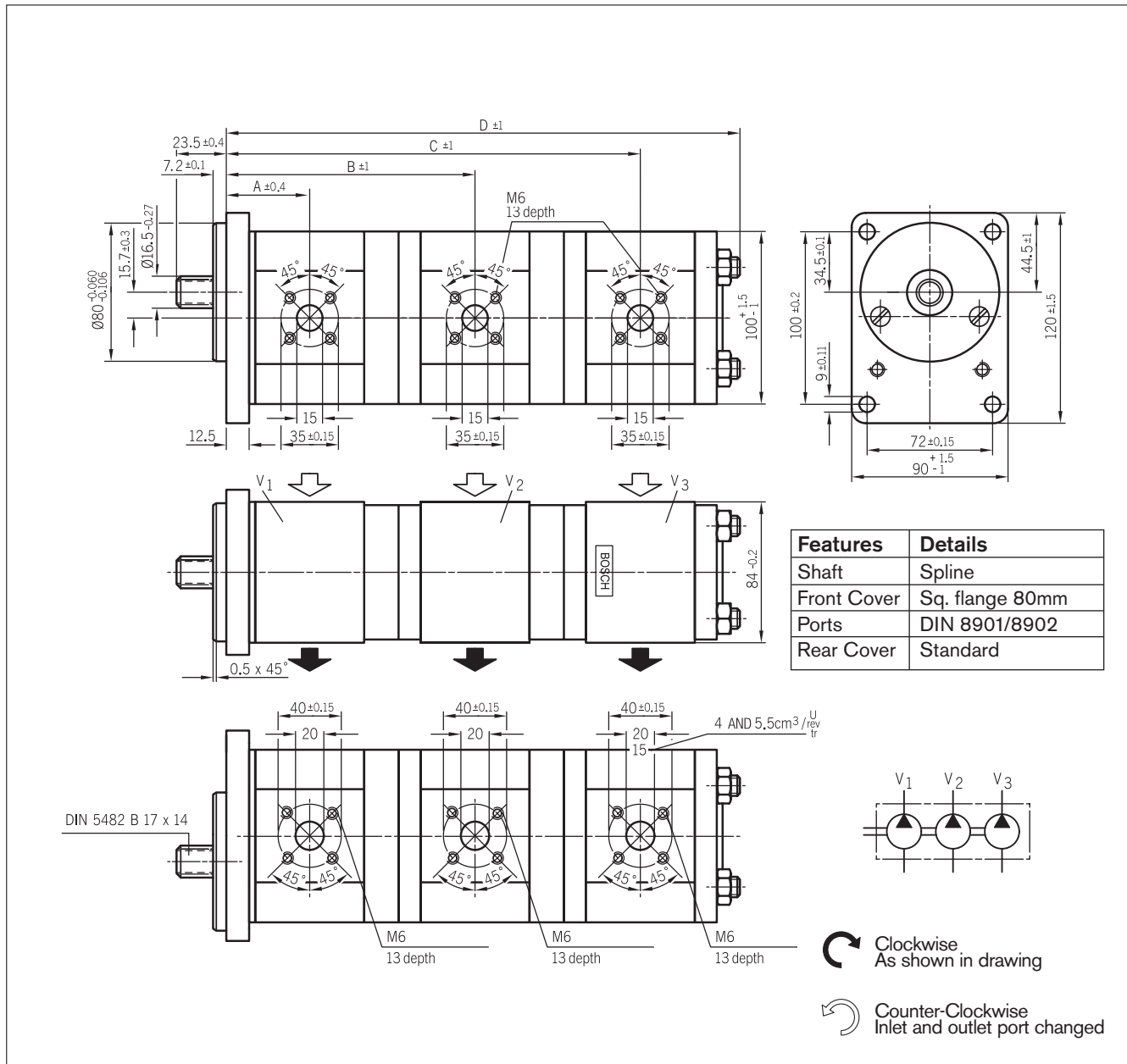

**Ordering code**

**AZPFF - X X -** □□□ / □□□□□□□□□□ **F B 20 20 20 MB**

Displacement [cm <sup>3</sup> /rev]	Ordering-Number *		Max. operating pressure [bar]	Max. rotation speed [min <sup>-1</sup> ]	Dimension [mm]			
	L	R			A	B	C	D
011 / 004 / 004	<b>0 510 565 371</b>		280	3500	47.0	133.2	214.9	262.5
014 / 004 / 008	<b>0 510 565 408</b>		280	3000	47.5	138.2	223.2	272.5
016 / 004 / 004	<b>0 510 665 379</b>		280	3000	47.5	141.5	223.3	270.0
016 / 05.5 / 05.5		<b>0 510 656 061</b>	280	3000	47.5	142.8	227.0	277.5
016 / 05.5 / 05.5	<b>0 510 665 416</b>		280	3000	47.5	142.8	227.0	277.5
016 / 011 / 004	<b>0 510 665 372</b>		280/210/210	3000	47.5	148.7	234.9	282.0
016 / 016 / 011	<b>0 510 665 371</b>		280/120/120	3000	47.5	149.2	250.4	302.0

\* Contact factory for availability of units with no ordering number listed.

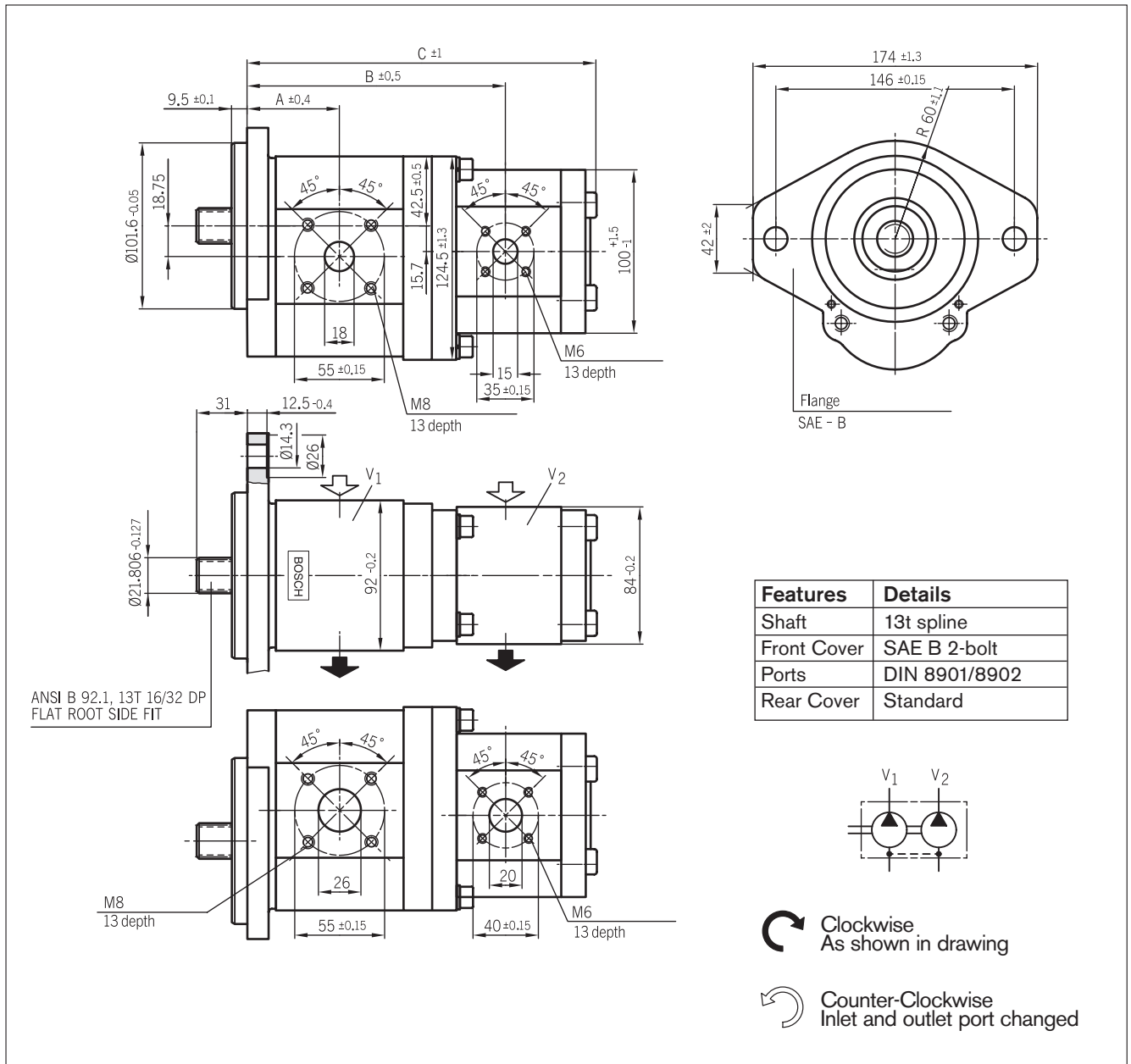

**Ordering code**

**AZPNF - X X - □□□ / □□□□ D C 20 20 KB**

Displacement [cm <sup>3</sup> /rev]	Ordering-Number *		Max. operating pressure [bar]	Max. rotation speed [min <sup>-1</sup> ]	Dimension [mm]		
	L	R			A	B	C
025 / 014		<b>0 510 766 010</b>	250	3000	55.1	155.1	209.2
028 / 016	<b>0 510 767 311</b>	<b>0 510 767 018</b>	230	2800	56.5	158.0	215.6
032 / 014		<b>0 510 768 021</b>	200/250	2800	59.0	162.6	216.7

\* Contact factory for availability of units with no ordering number listed.

**Seal Kits (reference Fig. 15)**

Example Model Code: AZPF – 12 – 008 RRR 12MB

Model Code Designator for Shaft | Model Code Designator for Seal

Model Code For Shaft	Shaft Description	Model Code For Seal		Seal Pos. 800 & Pos. 3	Sets of Seals Sps. 800	Shaft Seal Pos. 3	O-ring Pos. 31
		Seal Material					
F Series Pump	R SAE 9T Spline	M	NBR	1506635001	1517010152	1510283035	---
		P	FPM	---	1517010193	1510283027	---
		K	NBR W/FPM SHAFT SEAL	---	1517010152	1510283027	---
	Q 5/8" Straight Key	M	NBR	1506635001	1517010152	1510283035	---
		P	FPM	---	1517010193	1510283027	---
		K	NBR W/FPM SHAFT SEAL	---	1517010152	1510283027	---
	P SAE 11T Spline	M	NBR	1506635003	1517010152	1510283037	---
		P	FPM	---	1517010193	1510283044	---
		K	NBR W/FPM SHAFT SEAL	---	1517010152	1510283044	---
	C 1:5 Tapered Key	M	NBR	1506635001	1517010152	1510283038	---
		P	FPM	---	1517010193	1510283027	---
		K	NBR W/FPM SHAFT SEAL	---	1517010152	1510283027	---
	S 1:5 Tapered for Flange A	M	NBR	---	1517010152	1510283009	---
		P	FPM	---	1517010193	1510283015	---
		K	NBR W/FPM SHAFT SEAL	---	1517010152	1510283015	---
H 1:8 Tapered Key	M	NBR	1506635001	1517010152	1510283008	---	
	P	FPM	---	1517010193	1510283027	---	
	K	NBR W/FPM SHAFT SEAL	---	1517010152	1510283027	---	
N Dog	M	NBR	1506635001	1517010152	1510283008	1900210145	
	P	FPM	---	1517010193	1510283027	1900210145	
	K	NBR W/FPM SHAFT SEAL	---	1517010152	1510283027	---	
A 18mm Straight Key	M	NBR	1506635003	1517010152	1510283037	---	
	P	FPM	---	1517010193	1510283027	---	
	K	NBR W/FPM SHAFT SEAL	---	1517010152	1510283027	---	
F Din 5482 B17x14 Spline	M	NBR	1506635001	1517010152	1510283008	---	
	P	FPM	---	1517010193	1510283027	---	
	K	NBR W/FPM SHAFT SEAL	---	1517010152	1510283027	---	
N Series Pump	P SAE 11T Spline	M	NBR	1509635001	1517010194	1510283023	---
		P	FPM	---	1517010197	1510283028	---
		K	NBR W/FPM SHAFT SEAL	---	1517010194	1510283028	---
	Q SAE 3/4" Keyed Shaft	M	NBR	1509635001	1517010194	1510283023	---
		P	FPM	---	1517010197	1510283028	---
		K	NBR W/FPM SHAFT SEAL	---	1517010194	1510283028	---
	R SAE 9T Spline	M	NBR	1509635001	1517010194	1510283023	---
		P	FPM	---	1517010197	1510283028	---
		K	NBR W/FPM SHAFT SEAL	---	1517010194	1510283028	---
	D SAE 13T Spline	M	NBR	1509635001	1517010194	1510283023	---
		P	FPM	---	1517010197	1510283028	---
		K	NBR W/FPM SHAFT SEAL	---	1517010194	1510283028	---
	Q-S0022 SAE 3/4" Keyed, Long	M	NBR	1509635001	1517010194	1510283023	---
		P	FPM	---	1517010197	1510283028	---
		K	NBR W/FPM SHAFT SEAL	---	1517010194	1510283028	---
C 1:5 Tapered Key	M	NBR	1509635001	1517010194	1510283023	---	
	P	FPM	---	1517010197	1510283028	---	
	K	NBR W/FPM SHAFT SEAL	---	1517010194	1510283028	---	
N Dog (tang)	M	NBR	1509635001	1517010194	1510283023	---	
	P	FPM	---	1517010197	1510283028	---	
	K	NBR W/FPM SHAFT SEAL	---	1517010194	1510283028	---	
H 1:8 Tapered Key	M	NBR	1509635001	1517010194	1510283023	---	
	P	FPM	---	1517010197	1510283028	---	
	K	NBR W/FPM SHAFT SEAL	---	1517010194	1510283028	---	
A ISO Keyed, 18mm	M	NBR	1509635001	1517010194	1510283023	---	
	P	FPM	---	1517010197	1510283028	---	
	K	NBR W/FPM SHAFT SEAL	---	1517010194	1510283028	---	
G Series Pump	D SAE B - 13T Spline	M	NBR	---	1517010190	1510283010	---
		P	FPM	---	1517010203*	1510283068	---
		K	NBR W/FPM SHAFT SEAL	---	1517010190	1510283068	---
	Q SAE 7/8" Keyed Shaft	M	NBR	---	1517010190	1510283010	---
		P	FPM	---	1517010203*	1510283025	---
		K	NBR W/FPM SHAFT SEAL	---	1517010190	1510283025	---
	C 1:5 Tapered Key	M	NBR	---	1517010190	1510283010	---
		P	FPM	---	---	---	---
		K	NBR W/FPM SHAFT SEAL	---	1517010190	1510283025	---
	S 1:5 Tapered Key (flange A)	M	NBR	---	1517010190	1510283010	---
		P	FPM	---	---	---	---
		K	NBR W/FPM SHAFT SEAL	---	---	---	---
	H 1:8 Tapered Key	M	NBR	---	1517010190	1510283010	---
		P	FPM	---	---	---	---
		K	NBR W/FPM SHAFT SEAL	---	---	---	---
N Dog (tang)	M	NBR	---	1517010190	1510283010	---	
	P	FPM	---	---	---	---	
	K	NBR W/FPM SHAFT SEAL	---	---	---	---	
F DIN 5482 B17x14 Spline	M	NBR	---	1517010190	1510283014	---	
	P	FPM	---	---	---	---	
	K	NBR W/FPM SHAFT SEAL	---	---	---	---	

\* only housing seal are in FPM

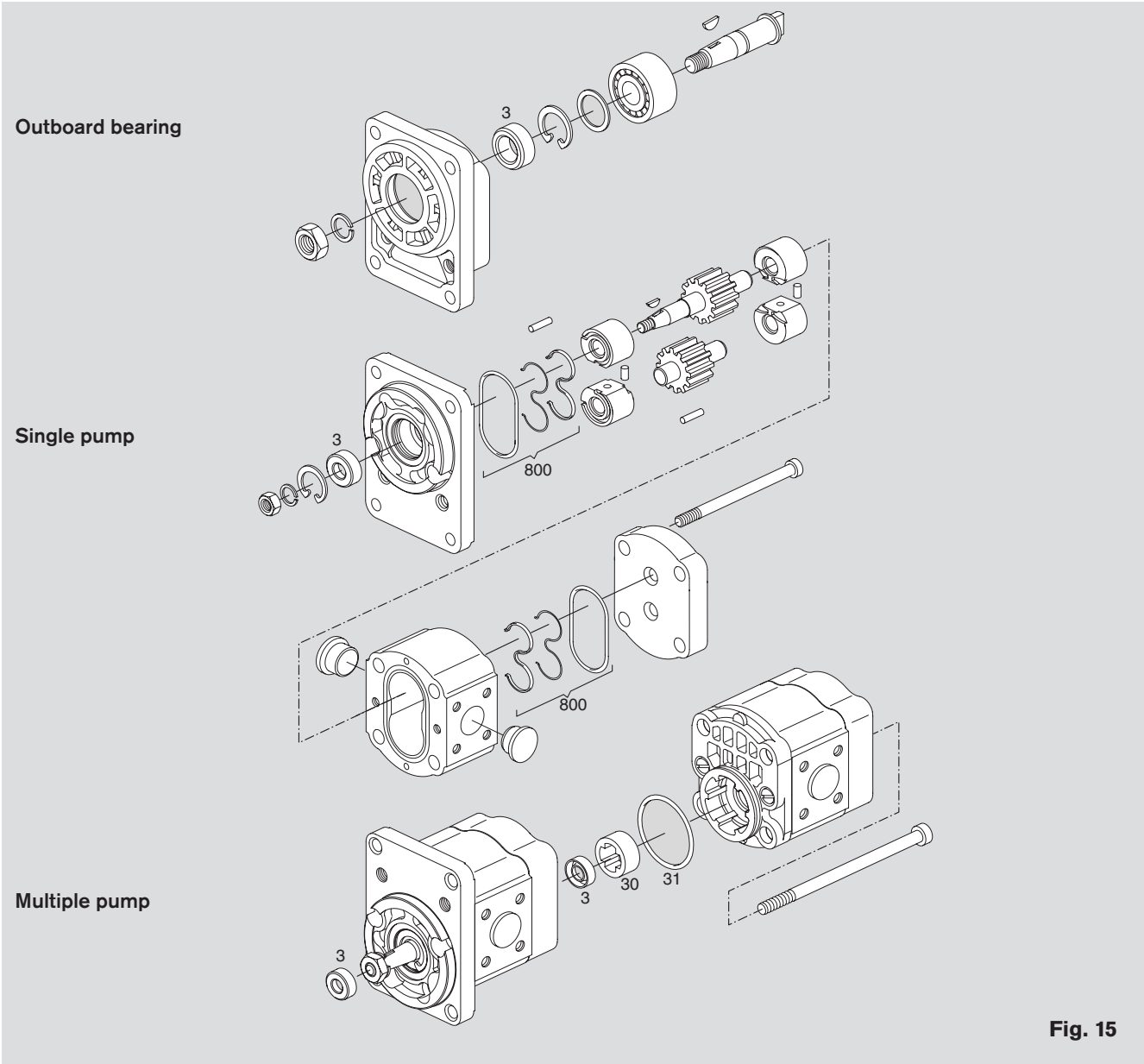

Fig. 15

# Part Number Index

## External Gear Pumps – Multiple Pumps

Part Number	Page	Part Number	Page	Part Number	Page	Part Number	Page
0 510 215 006	37	0 510 515 019	41	0 510 625 028	31	0 510 765 023	85
0 510 215 007	41	0 510 515 309	39	0 510 625 029	31	0 510 765 312	87
0 510 215 009	39	0 510 515 310	37	0 510 625 035	66	0 510 765 317	86
0 510 215 306	37	0 510 515 311	41	0 510 625 047	36	0 510 765 320	85
0 510 215 307	41	0 510 515 316	39	0 510 625 052	36	0 510 765 331	86
0 510 215 309	39	0 510 515 337	40	0 510 625 314	32	0 510 766 010	91
0 510 225 006	32	0 510 515 338	40	0 510 625 315	32	0 510 767 018	91
0 510 225 007	33	0 510 515 340	41	0 510 625 316	33	0 510 767 311	91
0 510 225 008	34	0 510 525 009	32	0 510 625 317	33	0 510 768 021	91
0 510 225 013	31	0 510 525 010	33	0 510 625 318	34	9 510 290 004	23
0 510 225 015	36	0 510 525 011	34	0 510 625 319	34	9 510 290 005	23
0 510 225 306	32	0 510 525 012	34	0 510 625 329	31	9 510 290 015	23
0 510 225 307	33	0 510 525 018	32	0 510 625 330	31	9 510 290 017	23
0 510 225 308	34	0 510 525 019	31	0 510 625 335	66	9 510 290 018	23
0 510 225 314	31	0 510 525 020	31	0 510 645 002	42	9 510 290 021	25
0 510 245 001	42	0 510 525 024	35	0 510 645 003	43	9 510 290 022	25
0 510 245 300	42	0 510 525 030	33	0 510 645 004	42	9 510 290 023	25
0 510 255 300	89	0 510 525 039	36	0 510 645 005	43	9 510 290 024	25
0 510 315 004	37	0 510 525 040	36	0 510 645 300	42	9 510 290 025	25
0 510 315 005	41	0 510 525 311	32	0 510 655 001	89	9 510 290 034	82
0 510 315 006	39	0 510 525 312	33	0 510 655 002	89	9 510 290 036	23
0 510 315 007	38	0 510 525 313	34	0 510 655 003	89	9 510 290 037	23
0 510 315 304	37	0 510 525 314	34	0 510 655 004	89	9 510 290 038	23
0 510 315 305	41	0 510 525 319	32	0 510 655 005	89	9 510 290 039	23
0 510 315 307	39	0 510 525 323	35	0 510 655 300	89	9 510 290 040	23
0 510 325 006	32	0 510 525 324	31	0 510 655 301	89	9 510 290 044	25
0 510 325 007	33	0 510 525 325	31	0 510 655 302	89	9 510 290 045	25
0 510 325 008	34	0 510 525 328	33	0 510 655 303	89	9 510 290 046	25
0 510 325 013	31	0 510 545 001	42	0 510 655 304	89	9 510 290 047	25
0 510 325 018	36	0 510 545 002	43	0 510 656 061	90	9 510 290 048	25
0 510 325 306	32	0 510 545 003	43	0 510 665 022	86	9 510 290 052	83
0 510 325 307	33	0 510 545 300	42	0 510 665 024	85	9 510 290 056	23
0 510 325 308	34	0 510 545 302	43	0 510 665 025	85	9 510 290 057	27
0 510 325 313	31	0 510 555 001	89	0 510 665 030	87	9 510 290 058	27
0 510 345 001	42	0 510 555 002	89	0 510 665 053	85	9 510 290 059	27
0 510 345 300	42	0 510 555 003	89	0 510 665 067	85	9 510 290 060	27
0 510 355 301	89	0 510 555 300	89	0 510 665 097	86	9 510 290 061	27
0 510 365 010	87	0 510 555 301	89	0 510 665 325	85	9 510 290 062	27
0 510 365 314	87	0 510 555 302	89	0 510 665 326	85	9 510 290 063	27
0 510 415 005	37	0 510 565 012	85	0 510 665 327	85	9 510 290 064	27
0 510 415 006	41	0 510 565 015	87	0 510 665 371	90	9 510 290 065	27
0 510 415 313	37	0 510 565 016	87	0 510 665 372	90	9 510 290 066	27
0 510 415 314	41	0 510 565 022	88	0 510 665 375	86	9 510 290 067	27
0 510 415 316	39	0 510 565 023	88	0 510 665 379	90	9 510 290 068	27
0 510 415 328	40	0 510 565 033	85	0 510 665 400	85	9 510 290 069	27
0 510 425 009	32	0 510 565 037	85	0 510 665 416	90	9 510 290 070	27
0 510 425 010	33	0 510 565 078	87	0 510 665 420	86	9 510 290 071	27
0 510 425 011	34	0 510 565 329	87	0 510 715 004	41	9 510 290 072	27
0 510 425 020	31	0 510 565 339	87	0 510 715 006	67	9 510 290 075	24
0 510 425 021	35	0 510 565 346	88	0 510 715 007	67	9 510 290 076	24
0 510 425 027	36	0 510 565 353	85	0 510 715 008	40	9 510 290 077	24
0 510 425 307	32	0 510 565 364	85	0 510 715 016	37	9 510 290 078	24
0 510 425 308	33	0 510 565 371	90	0 510 715 306	39	9 510 290 079	24
0 510 425 309	34	0 510 565 379	87	0 510 715 307	41	9 510 290 080	24
0 510 425 314	31	0 510 565 408	90	0 510 715 320	40	9 510 290 081	24
0 510 425 315	35	0 510 615 005	39	0 510 725 030	32	9 510 290 082	24
0 510 445 001	42	0 510 615 006	37	0 510 725 031	34	9 510 290 083	24
0 510 445 300	42	0 510 615 007	41	0 510 725 047	66	9 510 290 084	24
0 510 455 001	89	0 510 615 008	41	0 510 725 048	66	9 510 290 085	24
0 510 455 002	89	0 510 615 009	38	0 510 725 055	66	9 510 290 086	24
0 510 455 300	89	0 510 615 010	39	0 510 725 057	65	9 510 290 087	24
0 510 455 301	89	0 510 615 023	40	0 510 725 058	65	9 510 290 088	24
0 510 465 008	87	0 510 615 314	37	0 510 725 062	33	9 510 290 089	24
0 510 465 012	87	0 510 615 315	41	0 510 725 077	31	9 510 290 090	24
0 510 465 340	85	0 510 615 317	39	0 510 725 084	36	9 510 290 091	26
0 510 465 346	87	0 510 615 318	39	0 510 725 330	32	9 510 290 092	26
0 510 515 004	37	0 510 615 321	41	0 510 725 331	34	9 510 290 093	26
0 510 515 005	41	0 510 615 341	37	0 510 725 352	66	9 510 290 094	26
0 510 515 007	39	0 510 625 013	32	0 510 725 353	66	9 510 290 095	26
0 510 515 011	38	0 510 625 014	33	0 510 725 361	31	9 510 290 096	26
0 510 515 012	40	0 510 625 015	33	0 510 725 363	65	9 510 290 097	26
0 510 515 013	40	0 510 625 016	34	0 510 725 364	66	9 510 290 098	26
0 510 515 015	37	0 510 625 017	34	0 510 725 377	65	9 510 290 099	26
0 510 515 018	39	0 510 625 022	32	0 510 765 012	85	9 510 290 100	26

Part Number	Page	Part Number	Page	Part Number	Page	Part Number	Page
9 510 290 101	26	9 510 390 015	60	9 510 390 094	52	9 510 390 175	62
9 510 290 102	26	9 510 390 016	60	9 510 390 095	52	9 510 390 176	62
9 510 290 103	26	9 510 390 017	60	9 510 390 096	52	9 510 390 177	62
9 510 290 104	26	9 510 390 018	60	9 510 390 097	52	9 510 390 178	62
9 510 290 105	26	9 510 390 019	60	9 510 390 098	50	9 510 390 179	62
9 510 290 106	26	9 510 390 020	60	9 510 390 099	50	9 510 390 180	62
9 510 290 108	84	9 510 390 021	60	9 510 390 100	50	9 510 390 188	62
9 510 290 110	27	9 510 390 022	60	9 510 390 101	50	9 510 390 190	61
9 510 290 111	23	9 510 390 023	60	9 510 390 102	50	9 510 490 004	73
9 510 290 112	25	9 510 390 024	60	9 510 390 103	50	9 510 490 005	73
9 510 290 113	27	9 510 390 025	57	9 510 390 104	50	9 510 490 007	73
9 510 290 114	23	9 510 390 026	57	9 510 390 105	50	9 510 490 009	73
9 510 290 115	25	9 510 390 027	57	9 510 390 106	50	9 510 490 010	73
9 510 290 116	27	9 510 390 028	57	9 510 390 107	50	9 510 490 014	73
9 510 290 117	23	9 510 390 029	57	9 510 390 108	50	9 510 490 015	73
9 510 290 118	25	9 510 390 030	57	9 510 390 109	50	9 510 490 017	73
9 510 290 119	27	9 510 390 031	57	9 510 390 110	63	9 510 490 019	73
9 510 290 120	23	9 510 390 032	57	9 510 390 111	63	9 510 490 020	73
9 510 290 121	25	9 510 390 033	57	9 510 390 112	63	9 510 490 024	75
9 510 290 122	25	9 510 390 034	57	9 510 390 113	63	9 510 490 025	75
9 510 290 123	25	9 510 390 035	57	9 510 390 114	63	9 510 490 027	75
9 510 290 124	25	9 510 390 036	57	9 510 390 115	63	9 510 490 029	75
9 510 290 125	23	9 510 390 037	58	9 510 390 116	63	9 510 490 030	75
9 510 290 126	23	9 510 390 038	58	9 510 390 117	63	9 510 490 034	75
9 510 290 127	23	9 510 390 039	58	9 510 390 118	63	9 510 490 035	75
9 510 290 128	23	9 510 390 040	58	9 510 390 119	63	9 510 490 037	75
9 510 290 129	23	9 510 390 041	58	9 510 390 120	63	9 510 490 039	75
9 510 290 130	25	9 510 390 042	58	9 510 390 121	63	9 510 490 040	75
9 510 290 131	25	9 510 390 043	58	9 510 390 122	56	9 510 490 044	77
9 510 290 132	25	9 510 390 044	58	9 510 390 123	56	9 510 490 045	77
9 510 290 133	28	9 510 390 045	58	9 510 390 124	56	9 510 490 047	77
9 510 290 134	29	9 510 390 046	58	9 510 390 125	56	9 510 490 049	77
9 510 290 135	29	9 510 390 047	58	9 510 390 126	56	9 510 490 050	77
9 510 290 137	83	9 510 390 048	58	9 510 390 127	56	9 510 490 054	77
9 510 290 138	83	9 510 390 049	53	9 510 390 128	56	9 510 490 055	77
9 510 290 139	83	9 510 390 050	53	9 510 390 129	56	9 510 490 057	77
9 510 290 140	83	9 510 390 051	53	9 510 390 130	56	9 510 490 059	77
9 510 290 141	83	9 510 390 052	53	9 510 390 131	56	9 510 490 060	77
9 510 290 142	82	9 510 390 053	53	9 510 390 132	56	9 510 490 064	74
9 510 290 143	82	9 510 390 054	53	9 510 390 133	56	9 510 490 065	74
9 510 290 144	82	9 510 390 055	53	9 510 390 134	64	9 510 490 067	74
9 510 290 191	28	9 510 390 056	53	9 510 390 135	64	9 510 490 069	74
9 510 290 209	28	9 510 390 057	53	9 510 390 136	64	9 510 490 070	74
9 510 290 210	28	9 510 390 058	53	9 510 390 137	64	9 510 490 074	74
9 510 290 211	28	9 510 390 059	53	9 510 390 138	64	9 510 490 075	74
9 510 290 212	28	9 510 390 060	53	9 510 390 139	64	9 510 490 077	74
9 510 290 213	29	9 510 390 061	54	9 510 390 140	64	9 510 490 079	74
9 510 290 214	28	9 510 390 062	54	9 510 390 141	64	9 510 490 080	74
9 510 290 215	28	9 510 390 063	54	9 510 390 142	64	9 510 490 084	78
9 510 290 323	30	9 510 390 064	54	9 510 390 143	64	9 510 490 085	78
9 510 290 324	30	9 510 390 065	54	9 510 390 144	64	9 510 490 087	78
9 510 290 325	30	9 510 390 066	54	9 510 390 145	64	9 510 490 089	78
9 510 290 326	30	9 510 390 067	54	9 510 390 147	49	9 510 490 090	78
9 510 290 327	30	9 510 390 068	54	9 510 390 148	49	9 510 490 094	78
9 510 290 328	30	9 510 390 069	54	9 510 390 149	49	9 510 490 095	78
9 510 290 329	30	9 510 390 070	54	9 510 390 150	49	9 510 490 097	78
9 510 290 330	30	9 510 390 071	54	9 510 390 151	49	9 510 490 099	78
9 510 290 331	30	9 510 390 072	54	9 510 390 152	49	9 510 490 100	78
9 510 290 332	30	9 510 390 073	55	9 510 390 153	49	9 510 490 104	76
9 510 290 254	28	9 510 390 074	55	9 510 390 154	49	9 510 490 105	76
9 510 290 255	28	9 510 390 075	55	9 510 390 155	49	9 510 490 107	76
9 510 290 256	28	9 510 390 076	55	9 510 390 156	49	9 510 490 109	76
9 510 290 257	28	9 510 390 077	55	9 510 390 157	49	9 510 490 110	76
9 510 290 259	28	9 510 390 078	55	9 510 390 158	49	9 510 490 114	76
9 510 390 001	59	9 510 390 079	55	9 510 390 159	51	9 510 490 115	76
9 510 390 002	59	9 510 390 080	55	9 510 390 160	51	9 510 490 117	76
9 510 390 003	59	9 510 390 081	55	9 510 390 161	51	9 510 490 119	76
9 510 390 004	59	9 510 390 082	55	9 510 390 162	51	9 510 490 120	76
9 510 390 005	59	9 510 390 083	55	9 510 390 163	51		
9 510 390 006	59	9 510 390 084	55	9 510 390 164	51		
9 510 390 007	59	9 510 390 086	52	9 510 390 165	51		
9 510 390 008	59	9 510 390 087	52	9 510 390 166	51		
9 510 390 009	59	9 510 390 088	52	9 510 390 167	51		
9 510 390 010	59	9 510 390 089	52	9 510 390 168	51		
9 510 390 011	59	9 510 390 090	52	9 510 390 169	51		
9 510 390 012	59	9 510 390 091	52	9 510 390 170	51		
9 510 390 013	60	9 510 390 092	52	9 510 390 173	61		
9 510 390 014	60	9 510 390 093	52	9 510 390 174	61		



Bosch Rexroth Corporation  
Mobile Hydraulics  
Mobile Controls, Electronics,  
and External Gear Units  
1700 Old Mansfield Road  
Wooster, OH 44691-0394  
Telephone (330) 263-3300  
Facsimile (330) 263-3330  
[www.boschrexroth-us.com](http://www.boschrexroth-us.com)

© 2006 Bosch Rexroth Corporation

All rights reserved. Neither this document, nor any part of it, may be reproduced, duplicated, circulated or disseminated, whether by copy, electronic format or any other means, without the prior consent and authorization of Bosch Rexroth Corp.

The data and illustrations in this brochure/data sheet are intended only to describe or depict the products. No representation or warranty, either express or implied, relating to merchantability or fitness for intended use, is given or intended by virtue of the information contained in this brochure/data sheet. The information contained in this brochure/data sheet in no way relieves the user of its obligation to insure the proper use of the products for a specific use or application. All products contained in this brochure/data sheet are subject to normal wear and tear from usage.

Subject to change.